

# KRINO<sup>®</sup>

## INDUSTRIAL

CUTTING TOOLS ENGINEERING



MASTERS OF QUALITY

KRINO<sup>®</sup> INDUSTRIAL CUTTING TOOLS ENGINEERING

ITALY 2015



**KRINO S.p.A.**  
Via Italia Unita, 21  
23876 Monticello Brianza (LC) - Italy  
Tel. 039 9230611 (Centralino)  
Tel. 039 9230605 (Vendite Italia)  
Fax 039 9208709 (Vendite Italia)

Tel. +39 039 9230611 (Switch Board)  
Tel. +39 039 9230604 (Export Department)  
Fax +39 039 9208712 (Export Department)

[www.krino.it](http://www.krino.it) - [info@krino.it](mailto:info@krino.it)



### **Punte rettificate in acciaio superrapido** **AISI M2, M35, M42** **Rivestimenti TiN, TiAlN**

HSS fully ground twist drills  
AISI M2, M35, M42  
TiN, TiAlN coating

page 6-99



### **Punte in metallo duro integrale** **Rivestimento TiAlN** **Con e senza fori di refrigerazione interna**

Carbide twist drills  
TiAlN coating  
With/without coolant holes

page 100-113



### **Punte rettificate in pollici** **AISI M2, M35** **Rivestimento TiN**

Fully ground twist drills, inches  
AISI M2, M35  
TiN coating

page 114-117



### **Utensili per la lavorazione della lamiera** **AISI M2, M35, metallo duro** **Rivestimenti TiN, TiAlN**

Tools for metal sheet  
AISI M2, M35, carbide  
TiN, TiAlN coating

page 118-151



### **Frese a carotare Weldon e Quick-In** **AISI M2, M35, metallo duro** **Rivestimento TiAlN**

Core drills Weldon or Quick-In shank  
AISI M2, M35, carbide  
TiAlN coating

page 152-163



### **Alesatori** **AISI M2, M35**

Reamers  
AISI M2, M35

page 164-173



### **Frese frontali** **AISI M42, metallo duro** **Rivestimento TiAlN**

End mills  
AISI M42, carbide  
TiAlN coating

page 174-238



### **Maschi a macchina** **AISI M2, M35, metallo duro** **Rivestimenti TiN, TiAlN** **Con e senza fori di refrigerazione interna**

Machine taps  
AISI M2, M35, carbide  
TiN, TiAlN coating  
With/without coolant holes

page 239-319



### **Filiere, maschi a mano, kit ripara filetti** **AISI M2, M35** **Rivestimenti TiN**

Round dies, hand taps, thread repairing kit  
AISI M2, M35  
TiN coating

page 320-391



## engineeringtools

► La nostra Azienda, forte di 30 anni di successo nella produzione e distribuzione degli utensili da taglio, è pronta a presentare una nuova linea di elevata qualità per la clientela industriale. Particolare attenzione è dedicata alla produzione di utensili innovativi, una qualità che significa massima efficienza nel taglio ed, insieme, totale sicurezza per gli utilizzatori. Rendimenti elevati si ottengono solo con una corretta scelta ed utilizzo degli utensili; di grande aiuto sono le informazioni tecniche, specifiche per ogni singolo prodotto, coadiuvate da simboli grafici, che trovate anche sulle singole confezioni dei prodotti.



Our company has been successfully manufacturing and distributing cutting tools for 30 years and is now ready to present a new range of high quality products for industrial customers. Special attention is devoted to the production of innovative tools, which is translated into maximum cutting efficiency and complete safety for users. Obtaining high performances requires the correct choice and use of tools. Technical information and specifications on each product is also helpful, supported by graphic symbols that are also found on the individual product packaging.

Notre société, forte de ses 30 années de succès dans la production et la distribution d'outils de coupe, se prépare à vous présenter une nouvelle gamme de produits de haute qualité pour les clients industriels. Une attention particulière est dédiée à la production d'outils novateurs, c'est une qualité qui signifie à la fois une efficacité maximale dans la coupe et une sécurité totale pour les utilisateurs. Les rendements élevés ne peuvent être garantis qu'avec le bon choix et la bonne utilisation des outils. Nos informations techniques sont très utiles, ainsi que les spécifications pour chaque produit, accompagnées de symboles graphiques, que vous retrouvez sur chaque emballage des produits.

Nuestra empresa, orgullosa de los 30 años de éxito en la producción y distribución de utensilios de corte, está preparada para presentar una nueva línea de elevada calidad para la clientela industrial. Se presta especial atención a la producción de utensilios innovadores, una calidad que significa máxima eficacia en el corte junto a una total seguridad para los usuarios. Los elevados rendimientos solo se obtienen eligiendo y utilizando correctamente los utensilios; además, son de gran ayuda las informaciones técnicas y las especificaciones de cada producto que van acompañadas de símbolos gráficos, que también se encuentran en los paquetes de los productos.

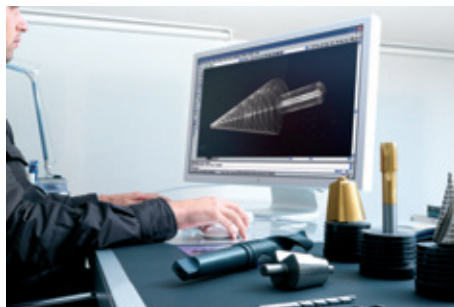

PROUDLY MADE IN ITALY >>



► L'esperienza specifica nella produzione degli utensili da taglio, in acciaio superrapido e in metallo duro, dei nostri ingegneri e dei tecnici di laboratorio, permettono un'assistenza tecnica qualificata ai nostri clienti. La formazione del nostro personale è attuata direttamente con corsi specifici, sia all'interno della nostra Azienda, così come presso le nostre associazioni di categoria come Confindustria. Corsi di formazione specifici sono inoltre effettuati all'interno del nostro sito, rivolti ai nostri Clienti, accompagnati dai nostri Agenti; l'esperienza è sempre positiva e molto gradita.

The specific expertise of our engineers and lab technicians in the manufacturing of cutting tools in HSS and hard metal enable us to provide qualified technical assistance to our customers. Our staff is trained with specific courses, both inside our Company and at industrial associations such as Confindustria. Specific training courses are also provided on our premises, targeted to customers who are accompanied by our agents; the experience is always positive and much appreciated.

L'expérience spécifique dans la fabrication d'outils de coupe en acier super rapide et en métal dur, de nos ingénieurs et techniciens de laboratoire, permet d'offrir un support technique qualifié à nos clients. La formation de notre personnel est effectuée directement par le biais de cours spécifiques, tant au sein de notre société qu'auprès d'associations professionnelles comme Confindustria. Des formations spécifiques sont également menées au sein de notre site, et sont adressées à nos clients accompagnés par nos agents.

L'expérience est toujours positive et très appréciée. La experiencia específica en la producción de utensilios de corte, de acero súper rápido y de metal duro por parte de nuestros ingenieros y de los técnicos de laboratorio nos permite ofrecer una asistencia técnica especializada a nuestros clientes. La formación de nuestro personal se efectúa directamente con cursos específicos, ya sea dentro de nuestra Empresa que en nuestras asociaciones de categoría, como por ejemplo Confindustria. También se efectúan en nuestro portal cursos de formación específicos dirigidos a nuestros Clientes y acompañados por nuestros Agentes. La experiencia resulta siempre positiva y muy agradecida.

Die spezielle Erfahrung bei der Produktion von Schneidwerkzeugen aus Hochleistungs-Schnellstahl und Hartmetall unserer Ingenieure und Labortechniker ermöglichen unseren Kunden eine qualifizierte technische Hilfe. Die Ausbildung unseres Personals erfolgt direkt durch spezifische Kurse, sowohl innerhalb unseres Unternehmens, als auch bei unseren Fachverbänden wie Confindustria. Spezifische Schulungen werden zudem innerhalb unseres Standortes durchgeführt. Sie richten sich unter Begleitung unserer Vertreter an unsere Kunden; die Erfahrung ist immer positiv und sehr willkommen.

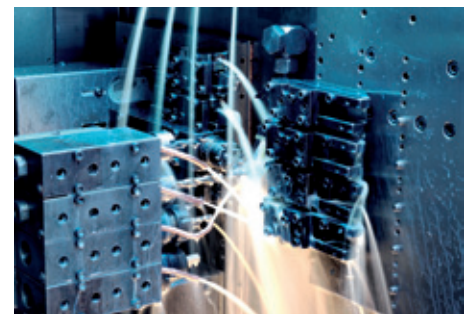

# WORLDWIDE

I mezzi e le modalità con cui comunicare oggi sono molto cambiati. Così l'eredità di Gutenberg oggi viaggia in rete, trova eco nei social network, si diffonde nei blog. Tutto è informazione, tutto è comunicazione.

**MULTI-CHANNEL/MOBILE COMMUNICATIONS: SMART-PHONES AND TABLETS** - The method and means of communication reflect the times. Thus Gutenberg's legacy now travels over the net, echoed in the social networks and spreading on blogs. Everything is information, everything is communication.



WWW.KRINO.IT



# PACKAGING

L'alta qualità dei prodotti è ben rappresentata da innovative confezioni in plastica e cartoncino, che riportano tutte le indicazioni necessarie per un facile stoccaggio ed un appropriato uso del prodotto.

The high quality of the products is well represented by the modern plastic and carton boxes which have the necessary information to stock and use the product.

La haute qualité des produits est bien représentée par des emballages novateurs en plastique et carton léger, comportant toutes les indications nécessaires pour un stockage facile et un usage approprié du produit.

La alta calidad de los productos está bien representada por paquetes novedosos en plástico y cartulina, que llevan todas las indicaciones necesarias para un fácil almacenamiento y un uso adecuado del producto.



Disponibilità garantita dei prodotti a catalogo prossima al **100%**  
Near **100%** guaranteed stock availability on catalogue products



Azienda con sistema di qualità certificato ISO9001  
Factory with ISO9001 certified quality system

**Ricerca, progettazione e produzione di utensili da taglio e utensili per avvitatori.**

## PROPRIETÀ INTELLETTUALE

Le fotografie, i disegni, le tabelle e tutte le note tecniche del presente catalogo sono puramente indicative. La società non è a queste in alcun modo vincolata e si riserva quindi il diritto di modifica secondo il proprio esclusivo giudizio. La riproduzione, anche parziale, di ogni parte del presente catalogo è vietata.

Photographies, dessins, tableaux et détails techniques contenus dans ce catalogue sont purement indicatifs. La Société n'est absolument pas engagée à ces derniers et se réserve le droit d'apporter des modifications selon son jugement exclusif.

Fotografías, dibujos, tablas y detalles técnicos de este catálogo son puramente indicativos. Nuestra Sociedad no es en ninguna manera vinculada a los mismos y se reserva el derecho de modifica según el propio exclusivo juicio.

Pictures, tables, drawings and technical specifications contained into the present catalogue are merely indicative. Our Company is not, in any case bound of those images and it reserves the right to make the modifications according to its exclusive judgment.



# UTENSILI SPECIALI A DISEGNO

SPECIAL TOOLS ON DEMAND / OUTILS SPÉCIAUX SUR DESSIN / UTENSILIOS ESPECIALES

► La domanda di utensileria speciale è in forte crescita. La nostra Azienda è pronta a soddisfare tutte le nuove esigenze di utensili in metallo duro integrale, insieme alla classica gamma di utensili tradizionali in acciaio HSS e HSS-Co: la qualità è garantita. Fornendo un disegno tecnico specifico, insieme alle indicazioni delle tipologie di materiale da lavorare, sarà possibile ottenere in breve tempo la relativa quotazione e tempistica di fornitura.

The demand for special tools is growing strongly. Our company is prepared to meet all the new requirements for tools in solid CARBIDE, and also for the classic range of traditional tools in HSS and HSS-Co steel. For a prompt pricing quote and delivery time, provide us with a specific technical design, along with indications on the types of materials to be machined.

La demande d'outils spéciaux est en forte croissance. Notre entreprise est prête à satisfaire toutes les nouvelles exigences d'outils en métal dur intégral, avec la gamme classique des outils traditionnels en acier HSS et HSS-Co. En fournissant un dessin technique spécifique, avec les indications sur les types de matériaux à usiner, il sera possible d'obtenir en peu de temps les prix et les délais de livraison.

La demanda de utensilios especiales está aumentando cada vez más. Nuestra Empresa está preparada para satisfacer todas las nuevas exigencias de utensilios de metal duro integral, junto a la clásica gama de utensilios tradicionales de acero HSS y HSS-Co. Enviándonos un diseño técnico específico más las indicaciones de los tipos de materiales que hay que trabajar, en poco tiempo podrán obtener el relativo presupuesto y los tiempos de entrega.



# LEGENDA DELLE ICONE UTILIZZATE NEL CATALOGO

Key for the catalogue icons / Légende des icônes utilisées dans le catalogue

Leyenda de los iconos empleados en el catálogo / Legende der im Katalog verwendeten Symbole



Materiali di produzione degli utensili: i principali sono l'acciaio superrapido HSS (AISI M2) con durezza HRC 64÷65, l'acciaio HSS Co5% (AISI M35) con durezza HRC 64÷66, e HSS Co8% (AISI M42) con durezza HRC 66÷68. / Tools materials: the mostly used materials are HSS (AISI M2) with HRC 64÷65, HSS Co5% (AISI M35) with HRC 64÷66, HSS Co8% (AISI M42) with HRC 66÷68. / Matériaux de production des outils: les principaux outils sont l'acier super rapide HSS (AISI M2) avec dureté HRC 64 à 65, l'acier HSS Co5 % (AISI M35) avec une dureté HRC 64 à 66 et HSS Co8 % (AISI M42) avec une dureté HRC 66 à 68. / Materiales de producción de los utensilios: los principales son el acero súper rápido HSS (AISI M2) con dureza HRC 64÷65, el acero HSS Co5% (AISI M35) con dureza HRC 64÷66, y HSS Co8% (AISI M42) con dureza HRC 66÷68.



Rivestimenti disponibili: TiN (colore dorato), che garantisce una durezza superficiale di HV 0.05 2300, e TiAlN (colore grigio-viola), che assicura una durezza superficiale di HV 0.05 3300. / Rivestimenti disponibili: TiN (colore dorato), che garantisce una durezza superficiale di HV 0.05 2300, e TiAlN (colore grigio-viola), che assicura una durezza superficiale di HV 0.05 3300. / Revêtements disponibles: TiN (couleur dorée), qui garantit une dureté de surface HV 0,05 2300 et TiAlN (couleur gris-violet), qui garantit une dureté de surface HV 0,05 3300. / Revestimientos disponibles: TiN (color dorado), que garantiza una dureza superficial de HV 0.05 2300, y TiAlN (color gris-violeta), que asegura una dureza superficial HV 0.05 3300.



Norme di produzione degli utensili. / Norme di produzione degli utensili. / Normes de production des outils. / Normas de producción de los utensilios. / Produktionsvorschriften der Werkzeuge.

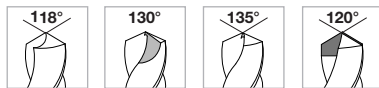

Tipologia di affilatura dell'utensile: si indica l'angolo dei taglienti, la presenza o meno di split point (secondo la norma DIN 1412/C) e la presenza o meno di canaline interne di refrigerazione. / Tipologia di affilatura dell'utensile: si indica l'angolo dei taglienti, la presenza o meno di split point (secondo la norma DIN 1412/C) e la presenza o meno di canaline interne di refrigerazione. / Type d'affûtage de l'outil: l'angle des bords de coupe, la présence ou pas de conduites de refroidissement internes sont indiqués. / Tipo de afilado del utensilio: se indica el ángulo de corte, con o sin afilado en cruz (conforme con la norma DIN 1412/C) y la presencia o ausencia de canales internos de refrigeración.

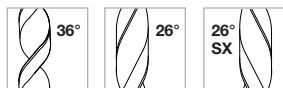

Inclinazione dell'elica nelle punte elicoidali cilindriche: destra o sinistra, con inclinazione standard 26° o più o meno rapida (20°, 35°, 36°). / Inclinazione dell'elica nelle punte elicoidali cilindriche: destra o sinistra, con inclinazione standard 26° o più o meno rapida (20°, 35°, 36°). / Inclinaison de l'hélice dans les forets hélicoïdaux cylindriques: droite ou gauche, avec inclinaison standard 26° ou plus ou moins rapide (20°, 35°, 36°). / Inclinación de la hélice en las puntas helicoidales cilíndricas: derecha o izquierda, con inclinación estándar 26° o más o menos rápida (20°, 35°, 36°).

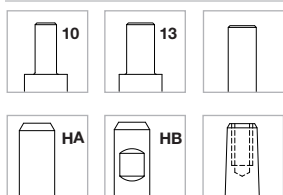

Tipologia di codolo dell'utensile: cilindrico, cilindrico ridotto, conico Morse (DIN 228), con o senza eventuali pianetti. / Tipologia di codolo dell'utensile: cilindrico, cilindrico ridotto, conico Morse (DIN 228), con o senza eventuali pianetti. / Typologie de cône de l'outil: cylindrique, cylindrique réduit, conique morse (DIN 228), avec ou sans éventuels plateaux. / Tipo de vástago del utensilio: cilíndrico, cilíndrico reducido, cono Morse (DIN 228), con o sin eventuales hendiduras. / Art des Werkzeugschaftes: zylindrisch, zylindrisch reduziert, Morsekegelschaft (DIN 228), mit oder ohne möglichen Ablagen.

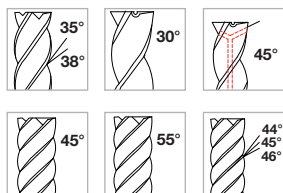

Geometria delle frese frontali: si evidenziano il numero di taglienti, l'angolo di inclinazione delle scanalature, la presenza o meno di canaline interne di refrigerazione. / Geometria delle frese frontali: si evidenziano il numero di taglienti, l'angolo di inclinazione delle scanalature, la presenza o meno di canaline interne di refrigerazione. / Géométrie des fraises frontales: le nombre de bords de coupe, l'angle d'inclinaison des rainures, la présence ou pas de conduites de refroidissement internes sont indiqués. / Geometría de las fresas frontales: destacan el número de bordes afilados, el ángulo de inclinación de las acanaladuras, la presencia o ausencia de canales internos de refrigeración. / Geometrie der Schafffräser: es wird die Anzahl der Schneidkanten, der Neigungswinkel der Nuten, das Vorhandensein oder Nicht-Vorhandensein von internen Kühlkanälen hervorgehoben.

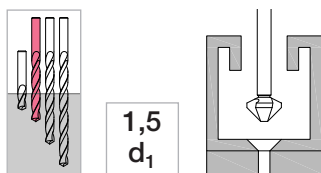

Consigli di utilizzo degli utensili: profondità di foratura consigliata, profondità di filettatura, ... / Tool use tips: cutting depth, threading depth, special applications, ... / Conseils d'utilisation des outils: profondeur de perçage conseillée, profondeur de filetage, applications spéciales, etc. / Consejos de uso de los utensilios: profundidad de perforado aconsejado, profundidad de fileteado, aplicaciones especiales ... / Hinweise zur Verwendung der Werkzeuge: empfohlene Bohrtiefe, Gewindetiefe, spezielle Anwendungen...



Materiali indicati per essere lavorati con l'utensile, in presenza o meno di lubrorefrigerazione. / Work-piece materials with or without coolant. / Matériaux recommandés pour être usinés avec l'outil, en présence ou pas de liquide de refroidissement. / Materiales indicados para trabajar con el utensilio, con o sin lubro-refrigeración. / Geeignete Materialien, um mit dem Werkzeug bearbeitet zu werden, bei Vorhandensein oder Nicht-Vorhandensein von Kühlschmiermitteln.

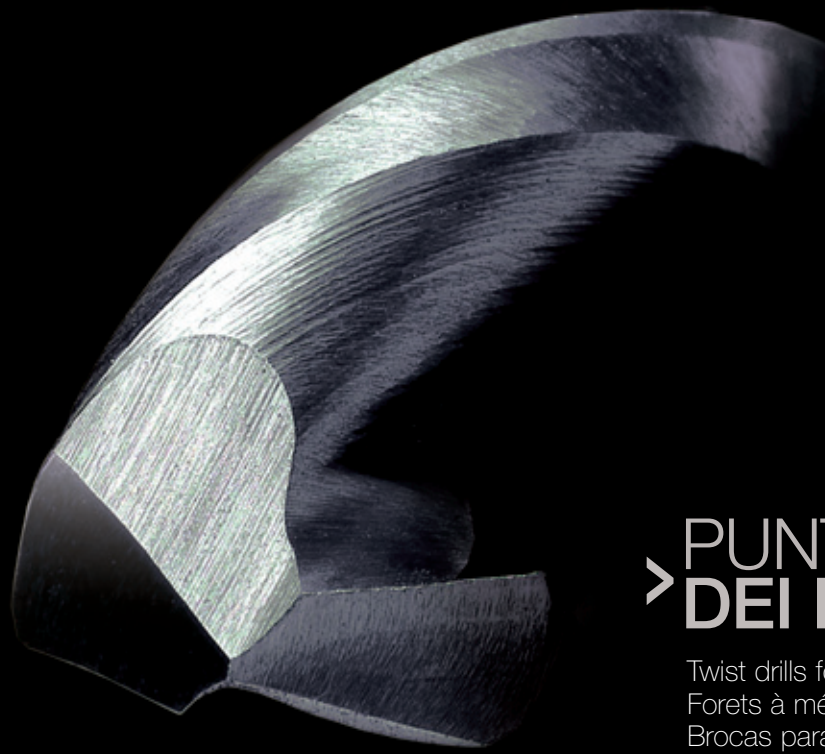

## > PUNTE PER IL TAGLIO DEI METALLI

Twist drills for metal cutting  
Forets à métaux  
Brocas para metales  
Metall-Spiralbohrer

La lavorazione dei fori nei metalli occupa più del 60% di tutte le lavorazioni per asportazione di truciolo ed è, al tempo stesso, una delle operazioni più difficoltose. L'esigenza di aumentare la produttività in queste lavorazioni, l'uso, oramai diffuso, di materiali da forare sempre più duri ha portato allo sviluppo di leghe di acciaio adeguate alle nuove ed impegnative richieste. La nostra Società, forte di una esperienza trentennale nella produzione di utensili per asportazione di truciolo, ha così sviluppato punte per trapano in **acciaio Superrapido** e nuovissime famiglie di punte in **metallo duro integrale**, ognuna con caratteristiche proprie, adatte alle necessità industriali. Insieme alle esigenze di competitività, che hanno spinto alle condizioni estreme i parametri di taglio, si va sempre più diffondendo una sensibilità ambientale che ha grande influenza sul modo di produrre e vendere i prodotti. Pertanto, mentre la nostra Azienda ottempera alle direttive internazionali sull'inquinamento, ha sviluppato utensili da taglio sempre più qualificati ed avanzati, che permettono un lavoro sicuro, rapido ed efficiente: ciò comporta un effettivo risparmio economico per il nostro cliente, con una benefica ricaduta ambientale.

## CUTTING TOOLS ENGINEERING

Gli acciai da utensili alto legati al 5% ed 8% di Cobalto permettono, grazie alle loro intrinseche caratteristiche metallurgiche, il taglio a secco dei materiali più difficili da lavorare, acciaio inox incluso: sono, perciò, "eco-friendly". Nelle lavorazioni industriali su moderni centri di lavoro, la generazione di calore, nel taglio, può essere eccessiva e superiore alla resistenza dell'acciaio rapido trattato termicamente. Si è così sviluppata la scienza di ricopertura dei materiali che, oltre ad un' intrinseca ed elevatissima durezza superficiale del sottilissimo strato di rivestimento, conferisce alla punta una notevole resistenza termica (grazie alla bassa conducibilità termica del rivestimento), una elevata capacità di evacuazione dei trucioli (basso coefficiente di attrito del rivestimento), evitando la saldatura del truciolo ai taglienti (il cosiddetto tagliente di riporto). Oltre al classico rivestimento colore oro al Nitruro di Titanio, la nostra Azienda presenta una linea di punte al Cobalto rivestite al Nitruro di Titanio - Alluminio prodotto con la Tecnologia PVD Magnetron di nuovissima generazione. Il rivestimento TiAlN, su base di AISI M35, ha una durezza 3300 HV 0,05 e tutte le caratteristiche positive, ulteriormente esaltate, dei rivestimenti (bassa conducibilità termica e basso coefficiente di attrito), che permettono il taglio intensivo, a secco, nelle leghe molto dure (acciai inox, acciai trattati) così come l'utilizzo in centri di lavoro H.S.C. (centri ad alti parametri di taglio).

Metal working accounts for over than 60% all process and the great use of strong alloys push our Company to develop models of HSS drills, every one with its own characteristics. Furthermore, in accordance with the international directives about pollution we develop more and more advanced and save tools which allow a real saving and a favorable impact on the environment.

Les perçages des métaux représente le 60% de tous les procès et la grand utilisation des allages très dures a poussé notre Société au développement de gammes de forets en acier HSS, tous avec leur propres caractéristiques. En outre, en accordance avec les normes internationales en matière de pollution, nous fabriquons des outillages sûres et avancés, qui permettent un réel épargne et un favorable impact sur l'environnement.

El corte de los metales representa el 60% de todos los trabajos y la gran utilización de aleaciones muy duras a permitido a nuestra empresa de introducir modelos de brocas HSS. Cada una con su propia característica. Además, con respecto a las directivas internacionales en materia de inquinamento, fabricamos utensilios seguros y avanzados que permiten un real ahorro y un favorable impacto con el ambiente.



## 01060

### Punte elicoidali cilindriche, esecuzione interamente rettificata, serie corta

Fully ground straight shank twist drills / Forets cylindriques rectifiés

Brocas helicoidales rectificadas / Geschliffene Spiralbohrer

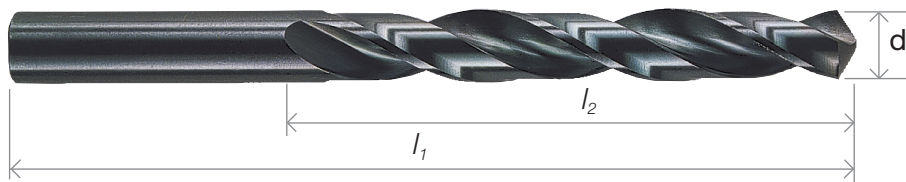
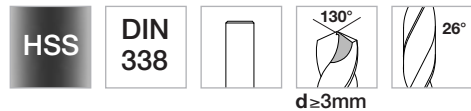

d	l <sub>2</sub>	l <sub>1</sub>		cod.	€ cad/each	d	l <sub>2</sub>	l <sub>1</sub>		cod.	€ cad/each
<b>h8</b>						<b>h8</b>					
<b>0,2</b>	1,5	25	10	010600020	2,236	1,7	20	43	10	010600170	0,921
0,21	1,5	25	10	010600021	2,236	<b>1,75</b>	22	46	10	010600175	0,921
0,22	1,5	25	10	010600022	2,236	1,8	22	46	10	010600180	0,921
0,23	1,5	25	10	010600023	2,236	1,9	22	46	10	010600190	0,921
0,24	1,5	25	10	010600024	2,236	<b>2</b>	24	49	10	010600200	0,807
<b>0,25</b>	1,9	25	10	010600025	2,236	2,1	24	49	10	010600210	0,973
0,26	1,9	25	10	010600026	2,236	2,2	27	53	10	010600220	0,973
0,27	1,9	25	10	010600027	2,236	<b>2,25</b>	27	53	10	010600225	0,973
0,28	1,9	25	10	010600028	2,236	2,3	27	53	10	010600230	0,973
0,29	1,9	25	10	010600029	2,236	2,4	30	57	10	010600240	0,973
<b>0,3</b>	3	19	10	010600030	2,236	<b>2,5</b>	30	57	10	010600250	0,890
0,35	4	19	10	010600035	2,029	2,6	30	57	10	010600260	1,118
0,4	5	20	10	010600040	1,925	2,7	33	61	10	010600270	1,118
0,45	5	20	10	010600045	1,925	<b>2,75</b>	33	61	10	010600275	1,118
<b>0,5</b>	6	22	10	010600050	1,656	2,8	33	61	10	010600280	1,118
0,55	7	24	10	010600055	1,925	2,9	33	61	10	010600290	1,118
0,6	7	24	10	010600060	1,521	<b>3</b>	33	61	10	010600300	1,014
0,65	8	26	10	010600065	1,656	3,1	36	65	10	010600310	1,201
0,7	9	28	10	010600070	1,418	3,2	36	65	10	010600320	1,201
<b>0,75</b>	9	28	10	010600075	1,418	<b>3,25</b>	36	65	10	010600325	1,201
0,8	10	30	10	010600080	1,418	3,3	36	65	10	010600330	1,201
0,85	10	30	10	010600085	1,418	3,4	39	70	10	010600340	1,201
0,9	11	32	10	010600090	1,325	<b>3,5</b>	39	70	10	010600350	1,128
0,95	11	32	10	010600095	1,418	3,6	39	70	10	010600360	1,314
<b>1</b>	12	34	10	010600100	1,076	3,7	39	70	10	010600370	1,314
1,1	14	36	10	010600110	1,128	<b>3,75</b>	39	70	10	010600375	1,314
1,2	16	38	10	010600120	1,128	3,8	43	75	10	010600380	1,314
<b>1,25</b>	16	38	10	010600125	1,128	3,9	43	75	10	010600390	1,314
1,3	16	38	10	010600130	1,128	<b>4</b>	43	75	10	010600400	1,232
1,4	18	40	10	010600140	1,128	4,1	43	75	10	010600410	1,625
<b>1,5</b>	18	40	10	010600150	0,973	4,2	43	75	10	010600420	1,625
1,6	20	43	10	010600160	0,921	<b>4,25</b>	43	75	10	010600425	1,625

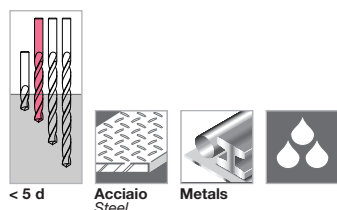



**Velocità di taglio consigliata / Recommended cutting speed**  
**Acciaio / Steel - 10 m/min**



Taglio dei materiali con R ≤ 800 N/mm<sup>2</sup> quali acciai legati, ghise, tutti i metalli in genere, la grafite. Precisione di foratura e costanza di rendimenti elevati. High precision and high performances in cutting alloy steel up to R ≤ 800 N/mm<sup>2</sup> / Puor percer métaux et acier avec R ≤ 800 N/mm<sup>2</sup> / Para taladrar hierro e acero R ≤ 800 N/mm<sup>2</sup> / Einsatz in Stahl und Stahlguss, legiert und unlegiert bis R ≤ 800 N/mm<sup>2</sup> Zug-Festigkeit, Ne-Metalle, Kunststoffe

19 pcs - Ø 1÷10 x 0,5 mm  
**01068301** € 49,163  
 25 pcs - Ø 1÷13 x 0,5 mm  
**01068302** € 99,360

d	$l_2$	$l_1$		cod.	€ cad/each	d	$l_2$	$l_1$		cod.	€ cad/each
h8						h8					
4,3	47	80	10	010600430	1,625	9,6	87	133	5	010600960	6,500
4,4	47	80	10	010600440	1,625	9,7	87	133	5	010600970	6,500
4,5	47	80	10	010600450	1,480	9,75	87	133	5	010600975	6,500
4,6	47	80	10	010600460	1,666	9,8	87	133	5	010600980	6,500
4,7	47	80	10	010600470	1,666	9,9	87	133	5	010600990	6,500
4,75	47	80	10	010600475	1,666	10	87	133	5	010601000	5,848
4,8	52	86	10	010600480	1,666	10,1	87	133	5	010601010	8,311
4,9	52	86	10	010600490	1,666	10,2	87	133	5	010601020	8,311
5	52	86	10	010600500	1,532	10,25	87	133	5	010601025	8,311
5,1	52	86	10	010600510	2,132	10,3	87	133	5	010601030	8,311
5,2	52	86	10	010600520	2,132	10,4	87	133	5	010601040	8,311
5,25	52	86	10	010600525	2,132	10,5	87	133	5	010601050	7,255
5,3	52	86	10	010600530	2,132	10,6	87	133	5	010601060	9,957
5,4	57	93	10	010600540	2,132	10,7	94	142	5	010601070	9,957
5,5	57	93	10	010600550	2,049	10,75	94	142	5	010601075	9,957
5,6	57	93	10	010600560	2,370	10,8	94	142	5	010601080	9,957
5,7	57	93	10	010600570	2,370	10,9	94	142	5	010601090	9,957
5,75	57	93	10	010600575	2,370	11	94	142	5	010601100	8,684
5,8	57	93	10	010600580	2,370	11,1	94	142	5	010601110	10,578
5,9	57	93	10	010600590	2,370	11,2	94	142	5	010601120	10,578
6	57	93	10	010600600	2,132	11,25	94	142	5	010601125	10,578
6,1	63	101	10	010600610	2,960	11,3	94	142	5	010601130	10,578
6,2	63	101	10	010600620	2,960	11,4	94	142	5	010601140	10,578
6,25	63	101	10	010600625	2,960	11,5	94	142	5	010601150	9,263
6,3	63	101	10	010600630	2,960	11,6	94	142	5	010601160	11,540
6,4	63	101	10	010600640	2,960	11,7	94	142	5	010601170	11,540
6,5	63	101	10	010600650	2,732	11,75	94	142	5	010601175	11,540
6,6	63	101	10	010600660	3,447	11,8	94	142	5	010601180	11,540
6,7	63	101	10	010600670	3,447	11,9	101	151	5	010601190	11,540
6,75	69	109	10	010600675	3,447	12	101	151	5	010601200	9,998
6,8	69	109	10	010600680	3,447	12,1	101	151	5	010601210	12,575
6,9	69	109	10	010600690	3,447	12,2	101	151	5	010601220	12,575
7	69	109	10	010600700	3,188	12,25	101	151	5	010601225	12,575
7,1	69	109	5	010600710	3,788	12,3	101	151	5	010601230	12,575
7,2	69	109	5	010600720	3,788	12,4	101	151	5	010601240	12,575
7,25	69	109	5	010600725	3,788	12,5	101	151	5	010601250	10,909
7,3	69	109	5	010600730	3,788	12,6	101	151	5	010601260	14,211
7,4	69	109	5	010600740	3,788	12,7	101	151	5	010601270	14,211
7,5	69	109	5	010600750	3,374	12,75	101	151	5	010601275	14,211
7,6	75	117	5	010600760	4,254	12,8	101	151	5	010601280	14,211
7,7	75	117	5	010600770	4,254	12,9	101	151	5	010601290	14,211
7,75	75	117	5	010600775	4,254	13	101	151	5	010601300	11,768
7,8	75	117	5	010600780	4,254	13,25	108	160	3	010601325	16,674
7,9	75	117	5	010600790	4,254	13,5	108	160	3	010601350	14,976
8	75	117	5	010600800	4,016	13,75	108	160	3	010601375	16,674
8,1	75	117	5	010600810	5,227	14	108	160	3	010601400	15,390
8,2	75	117	5	010600820	5,227	14,25	114	169	3	010601425	20,017
8,25	75	117	5	010600825	5,227	14,5	114	169	3	010601450	17,067
8,3	75	117	5	010600830	5,227	14,75	114	169	3	010601475	20,017
8,4	75	117	5	010600840	5,227	15	114	169	3	010601500	18,237
8,5	75	117	5	010600850	4,958	15,25	120	178	3	010601525	24,944
8,6	81	125	5	010600860	5,423	15,5	120	178	3	010601550	21,404
8,7	81	125	5	010600870	5,423	15,75	120	178	3	010601575	24,944
8,75	81	125	5	010600875	5,423	16	120	178	3	010601600	22,615
8,8	81	125	5	010600880	5,423	16,5	125	184	1	010601650	22,791
8,9	81	125	5	010600890	5,423	17	125	184	1	010601700	24,219
9	81	125	5	010600900	5,196	17,5	130	191	1	010601750	25,544
9,1	81	125	5	010600910	6,138	18	130	191	1	010601800	27,521
9,2	81	125	5	010600920	6,138	18,5	135	198	1	010601850	30,336
9,25	81	125	5	010600925	6,138	19	135	198	1	010601900	31,443
9,3	81	125	5	010600930	6,138	19,5	140	205	1	010601950	35,501
9,4	81	125	5	010600940	6,138	20	140	205	1	010602000	35,501
9,5	81	125	5	010600950	5,589						

## 01068

Assortimenti di punte elicoidali cilindriche, esecuzione interamente rettificata, serie corta

Fully ground straight shank twist drills / Forets cylindriques rectifiés

Brocas helicoidales rectificadas / Geschliffene Spiralbohrer

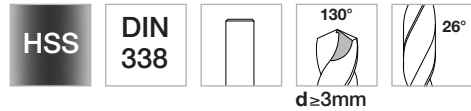

Metal

37 pcs - Ø 1÷10 x 0,25 mm

01068411 € 106,346

49 pcs - Ø 1÷13 x 0,25 mm

01068412 € 212,693

91 pcs - Ø 1÷10 x 0,1 mm

01068406 € 386,210

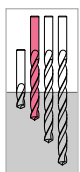

< 5 d



Acciaio  
Steel



Metals



Velocità di taglio consigliata / Recommended cutting speed  
Acciaio / Steel - 10 m/min



01068301

Taglio dei materiali con  $R \leq 800 \text{ N/mm}^2$  quali acciai legati, ghise, tutti i metalli in genere, la grafite. Precisione di foratura e costanza di rendimenti elevati. High precision and high performances in cutting alloy steel up to  $R \leq 800 \text{ N/mm}^2$  / Puor percer métaux et acier avec  $R \leq 800 \text{ N/mm}^2$  / Para taladrar hierro e acero  $R \leq 800 \text{ N/mm}^2$  / Einsatz in Stahl und Stahlguss, legiert und unlegiert bis  $R \leq 800 \text{ N/mm}^2$  Zug-Festigkeit, Ne-Metalle, Kunststoffe

# 01068

## Assortimenti di punte elicoidali cilindriche, esecuzione interamente rettificata, serie corta

Fully ground straight shank twist drills / Forets cylindriques rectifiés

Brocas helicoidales rectificadas / Geschliffene Spiralbohrer

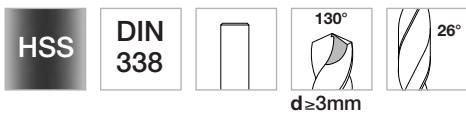

Metal

150 pcs - Ø 1 ÷ 10 x 0,5 mm  
Ø 1 ÷ 5 mm - 10 pcs  
Ø 3 mm - 20 pcs  
Ø 5,5 ÷ 10 mm - 5 pcs

01068450 € 304,497

 331x228x48

168 pcs - Ø 1 ÷ 13 x 0,5 mm  
Ø 1 ÷ 5 mm - 10 pcs  
Ø 3 mm - 20 pcs  
Ø 5,5 ÷ 10 mm - 5 pcs  
Ø 10,5 ÷ 13 mm - 3 pcs

01068451 € 503,755

 497x266x59

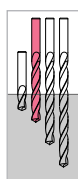

<math>d</math>



Acciaio  
Steel



Metals



Velocità di taglio consigliata / Recommended cutting speed  
Acciaio / Steel - 10 m/min

Taglio dei materiali con  $R \leq 800 \text{ N/mm}^2$  quali acciai legati, ghise, tutti i metalli in genere, la grafite. Precisione di foratura e costanza di rendimenti elevati. High precision and high performances in cutting alloy steel up to  $R \leq 800 \text{ N/mm}^2$  / Puor percer métaux et acier avec  $R \leq 800 \text{ N/mm}^2$  / Para taladrar hierro e acero  $R \leq 800 \text{ N/mm}^2$  / Einsatz in Stahl und Stahlguss, legiert und unlegiert bis  $R \leq 800 \text{ N/mm}^2$  Zug-Festigkeit, Ne-Metalle, Kunststoffe

## 01062

### Punte elicoidali cilindriche con codolo ridotto, interamente rettificate

Reduced shank twist drills / Forets cylindriques à queue réduite

Brocas helicoidales con mango reducido / Geschliffene Spiralbohrer mit reduzierten Schaft

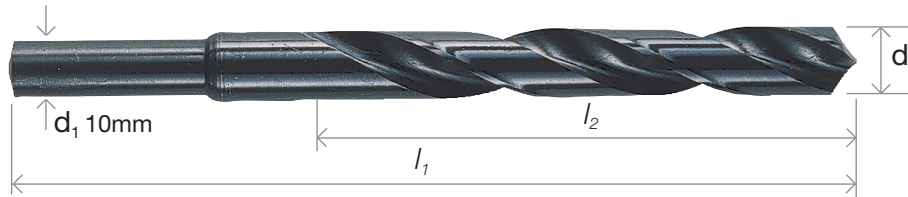
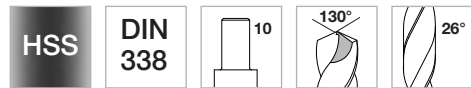

d	l <sub>2</sub>	l <sub>1</sub>	d <sub>1</sub>	h8	cod.	€ cad/each
10,25	87	133	10	5	010621025	10,661
<b>10,5</b>	87	133	10	5	010621050	9,605
10,75	94	142	10	5	010621075	12,306
<b>11</b>	94	142	10	5	010621100	11,033
11,25	94	142	10	5	010621125	12,927
<b>11,5</b>	94	142	10	5	010621150	11,613
11,75	94	142	10	5	010621175	13,890
<b>12</b>	101	151	10	5	010621200	12,348
12,25	101	151	10	5	010621225	14,925
<b>12,5</b>	101	151	10	5	010621250	13,258
12,75	101	151	10	5	010621275	16,570
<b>13</b>	101	151	10	5	010621300	14,117
13,25	108	160	10	3	010621325	19,355
<b>13,5</b>	108	160	10	3	010621350	17,667
13,75	108	160	10	3	010621375	19,355
<b>14</b>	108	160	10	3	010621400	18,081

d	l <sub>2</sub>	l <sub>1</sub>	d <sub>1</sub>	h8	cod.	€ cad/each
14,25	114	169	10	3	010621425	22,708
<b>14,5</b>	114	169	10	3	010621450	19,758
14,75	114	169	10	3	010621475	22,708
<b>15</b>	114	169	10	3	010621500	20,928
15,25	120	178	10	3	010621525	27,624
<b>15,5</b>	120	178	10	3	010621550	24,095
15,75	120	178	10	3	010621575	27,624
<b>16</b>	120	178	10	3	010621600	25,295
16,5	125	184	10	1	010621650	25,482
<b>17</b>	125	184	10	1	010621700	26,900
17,5	130	191	10	1	010621750	28,235
<b>18</b>	130	191	10	1	010621800	30,201
18,5	135	198	10	1	010621850	33,027
<b>19</b>	135	198	10	1	010621900	34,134
19,5	140	205	10	1	010621950	38,181
<b>20</b>	140	205	10	1	010622000	38,181

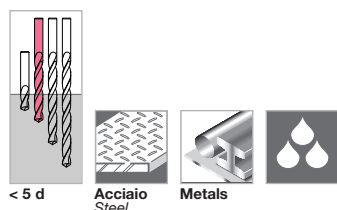

**Velocità di taglio consigliata / Recommended cutting speed**  
**Acciaio / Steel - 10 m/min**

Taglio dei materiali con R ≤ 800 N/mm<sup>2</sup> quali acciai legati, ghise, tutti i metalli in genere, la grafite. Precisione di foratura e costanza di rendimenti elevati. High precision and high performances in cutting alloy steel up to R ≤ 800 N/mm<sup>2</sup> / Puor percer métaux et acier avec R ≤ 800 N/mm<sup>2</sup> / Para taladrar hierro e acero R ≤ 800 N/mm<sup>2</sup> / Einsatz in Stahl und Stahlguss, legiert und unlegiert bis R ≤ 800 N/mm<sup>2</sup> Zug-Festigkeit, Ne-Metalle, Kunststoffe

# 01063

## Punte elicoidali cilindriche con codolo ridotto, interamente rettificate

Reduced shank twist drills / Forets cylindriques à queue réduite

Brocas helicoidales con mango reducido / Geschliffene Spiralbohrer mit reduzierten Schaft

HSS

DIN  
338

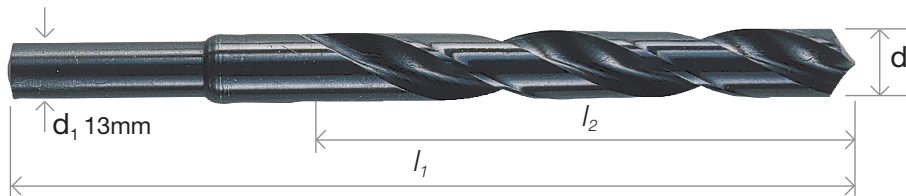

d	$l_2$	$l_1$	$d_1$		cod.	€ cad/each
h8						
13,25	108	160	13	3	010631325	19,355
<b>13,5</b>	108	160	13	3	010631350	17,667
13,75	108	160	13	3	010631375	19,355
<b>14</b>	108	160	13	3	010631400	18,081
14,25	114	169	13	3	010631425	22,708
<b>14,5</b>	114	169	13	3	010631450	19,758
14,75	114	169	13	3	010631475	22,708
<b>15</b>	114	169	13	3	010631500	20,920
15,25	120	178	13	3	010631525	27,624
<b>15,5</b>	120	178	13	3	010631550	24,095

d	$l_2$	$l_1$	$d_1$		cod.	€ cad/each
h8						
15,75	120	178	13	3	010631575	27,624
<b>16</b>	120	178	13	3	010631600	25,295
16,5	125	184	13	1	010631650	25,482
<b>17</b>	125	184	13	1	010631700	26,900
17,5	130	191	13	1	010631750	28,235
<b>18</b>	130	191	13	1	010631800	30,201
18,5	135	198	13	1	010631850	33,027
<b>19</b>	135	198	13	1	010631900	34,134
19,5	140	205	13	1	010631950	38,181
<b>20</b>	140	205	13	1	010632000	38,181

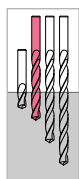

< 5 d



Acciaio  
Steel



Metals



Velocità di taglio consigliata / Recommended cutting speed

Acciaio / Steel - 10 m/min

Taglio dei materiali con  $R \leq 800 \text{ N/mm}^2$  quali acciai legati, ghise, tutti i metalli in genere, la grafite. Precisione di foratura e costanza di rendimenti elevati. High precision and high performances in cutting alloy steel up to  $R \leq 800 \text{ N/mm}^2$  / Puor percer métaux et acier avec  $R \leq 800 \text{ N/mm}^2$  / Para taladrar hierro e acero  $R \leq 800 \text{ N/mm}^2$  / Einsatz in Stahl und Stahlguss, legiert und unlegiert bis  $R \leq 800 \text{ N/mm}^2$  Zug-Festigkeit, Ne-Metalle, Kunststoffe

## 01094

### Punte elicoidali cilindriche, serie extra corta, interamente rettificate

Straight shank twist drills, stub serie / Forets cylindriques, série extra courte

Brocas helicoidales, serie extra corta / Geschliffene Spiralbohrer, extra kurz

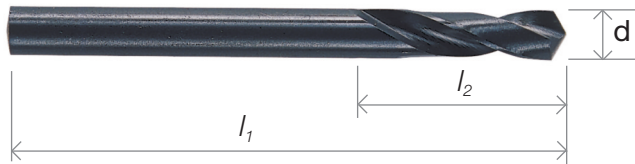
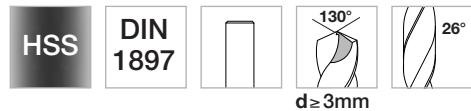

d h8	$l_2$	$l_1$		cod.	€ cad/each
1,5	9	32	10	010940150	0,776
2	12	38	10	010940200	0,776
2,2	13	40	10	010940220	0,942
2,25	13	40	10	010940225	0,942
2,5	14	43	10	010940250	0,859
2,75	16	46	10	010940275	1,066
2,8	16	46	10	010940280	1,066
3	16	46	10	010940300	1,066
3,1	18	49	10	010940310	1,170
3,2	18	49	10	010940320	1,170
3,25	18	49	10	010940325	1,170
3,5	20	52	10	010940350	1,170
3,7	20	52	10	010940370	1,294
3,75	20	52	10	010940375	1,294
3,8	22	55	10	010940380	1,294
4	22	55	10	010940400	1,294
4,1	22	55	10	010940410	1,615
4,2	22	55	10	010940420	1,615
4,25	22	55	10	010940425	1,615

d h8	$l_2$	$l_1$		cod.	€ cad/each
4,5	24	58	10	010940450	1,470
4,75	24	58	10	010940475	1,646
4,8	26	62	10	010940480	1,646
5	26	62	10	010940500	1,532
5,1	26	62	10	010940510	2,153
5,2	26	62	10	010940520	2,153
5,25	26	62	10	010940525	2,153
5,5	28	66	10	010940550	2,029
5,75	28	66	10	010940575	2,422
5,8	28	66	10	010940580	2,422
6	28	66	10	010940600	2,267
6,5	31	70	10	010940650	2,722
7	34	74	10	010940700	3,177
7,5	34	74	5	010940750	3,374
8	37	79	5	010940800	4,099
8,57	37	79	5	010940850	5,486
9	40	84	5	010940900	6,293
9,5	40	84	5	010940950	7,152
10	43	89	5	010941000	8,073

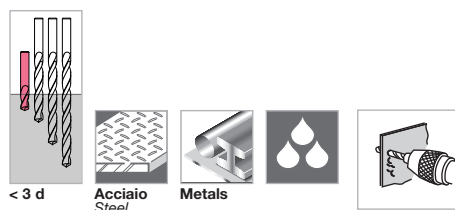

**Velocità di taglio consigliata / Recommended cutting speed**  
**Acciaio / Steel - 10 m/min**

Taglio dei materiali con  $R \leq 800 \text{ N/mm}^2$  quali acciai legati, ghise, tutti i metalli in genere, la grafite. Precisione di foratura e costanza di rendimenti elevati. High precision and high performances in cutting alloy steel up to  $R \leq 800 \text{ N/mm}^2$  / Puor percer métaux et acier avec  $R \leq 800 \text{ N/mm}^2$  / Para taladrar hierro e acero  $R \leq 800 \text{ N/mm}^2$  / Einsatz in Stahl und Stahlguss, legiert und unlegiert bis  $R \leq 800 \text{ N/mm}^2$  Zug-Festigkeit, Ne-Metalle, Kunststoffe



17 pcs - Ø 2 ÷ 10x0,5  
**01068221 € 87,975**

# 01095

## Punte doppie a elica contrapposta, interamente rettificate

Double ended twist drills / Forets rectifié hélixe opposé

Brocas rectificadas helice opuesta / Geschliffene Spiralbohrer, gegenüberliegend Schraube

HSS

Krino

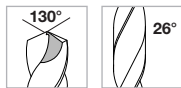

d ≥ 3mm



d	l <sub>2</sub>	l <sub>1</sub>		cod.	€ cad/each
2	10	38	10	010950200	1,387
2,5	10	43	10	010950250	1,387
3	11	46	10	010950300	1,594
3,2	11	49	10	010950320	1,594
3,25	11	49	10	010950325	1,594
3,3	11	49	10	010950330	1,594
3,4	14	52	10	010950340	1,594
3,5	14	52	10	010950350	1,594
3,75	14	55	10	010950375	1,791
4	14	55	10	010950400	1,791

d	l <sub>2</sub>	l <sub>1</sub>		cod.	€ cad/each
4,1	14	55	10	010950410	2,132
4,2	17	58	10	010950420	2,132
4,25	17	58	10	010950425	2,132
4,5	17	58	10	010950450	2,349
4,75	17	62	10	010950475	2,598
4,9	17	62	10	010950490	2,598
5	17	62	10	010950500	2,598
5,1	17	62	10	010950510	3,467
5,5	17	66	10	010950550	3,467
6	17	66	10	010950600	3,809

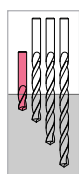

< 3 d



Acciaio  
Steel



Metals



Velocità di taglio consigliata / Recommended cutting speed  
Acciaio / Steel - 10 m/min

Taglio dei materiali con R ≤ 800 N/mm<sup>2</sup> quali acciai legati, ghise, tutti i metalli in genere, la grafite. Precisione di foratura e costanza di rendimenti elevati. High precision and high performances in cutting alloy steel up to R ≤ 800 N/mm<sup>2</sup> / Puor percer métaux et acier avec R ≤ 800 N/mm<sup>2</sup> / Para taladrar hierro e acero R ≤ 800 N/mm<sup>2</sup> / Einsatz in Stahl und Stahlguss, legiert und unlegiert bis R ≤ 800 N/mm<sup>2</sup> Zug-Festigkeit, Ne-Metalle, Kunststoff



## 01096

### Punte elicoidali cilindriche serie lunga, interamente rettificate

Long straight shank twist drills / Forets cylindriques série longue

Brocas helicoidales serie larga / Spiralbohrer, lange Ausführung

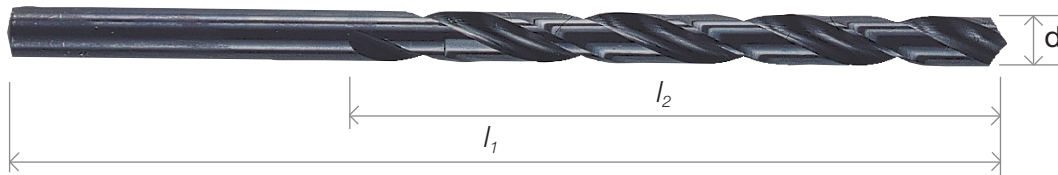
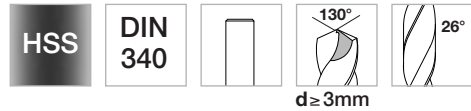

d	l <sub>2</sub>	l <sub>1</sub>		cod.	€ cad/each	d	l <sub>2</sub>	l <sub>1</sub>		cod.	€ cad/each
h8						h8					
1	33	56	10	010960100	1,666	8,25	109	165	5	010960825	9,698
1,5	45	70	10	010960150	1,666	8,5	109	165	5	010960850	9,698
1,75	53	80	10	010960175	1,842	8,75	115	175	5	010960875	10,153
2	56	85	10	010960200	1,749	9	115	175	5	010960900	10,153
2,25	59	90	10	010960225	1,935	9,25	115	175	5	010960925	11,426
2,5	62	95	10	010960250	1,842	9,5	115	175	5	010960950	10,878
2,75	66	100	10	010960275	2,132	9,75	121	184	5	010960975	12,513
3	66	100	10	010960300	2,132	10	121	184	5	010961000	11,923
3,25	69	106	10	010960325	2,318	10,5	121	184	5	010961050	14,376
3,5	73	112	10	010960350	2,267	11	128	195	5	010961100	14,614
3,75	73	112	10	010960375	2,412	11,5	128	195	5	010961150	16,136
4	78	119	10	010960400	2,298	12	134	205	5	010961200	17,574
4,25	78	119	10	010960425	2,919	12,5	134	205	5	010961250	18,154
4,5	82	126	10	010960450	2,960	13	134	205	5	010961300	21,269
4,75	82	126	10	010960475	3,022	13,5	140	214	3	010961350	29,332
5	87	132	10	010960500	2,877	14	140	214	3	010961400	29,332
5,25	87	132	10	010960525	3,985	14,5	144	220	3	010961450	41,514
5,5	91	139	10	010960550	3,985	15	144	220	3	010961500	39,537
5,75	91	139	10	010960575	4,357	15,5	149	227	3	010961550	48,190
6	91	139	10	010960600	4,357	16	149	227	3	010961600	45,902
6,25	97	148	5	010960625	4,927	16,5	154	235	1	010961650	47,579
6,5	97	148	5	010960650	4,689	17	154	235	1	010961700	48,924
6,75	97	148	5	010960675	5,744	17,5	158	241	1	010961750	54,296
7	102	156	5	010960700	5,268	18	158	241	1	010961800	55,186
7,25	102	156	5	010960725	6,479	18,5	162	247	1	010961850	62,690
7,5	102	156	5	010960750	6,169	19	162	247	1	010961900	63,922
7,75	109	165	5	010960775	7,369	19,5	166	254	1	010961950	67,730
8	109	165	5	010960800	7,017	20	166	254	1	010962000	68,553

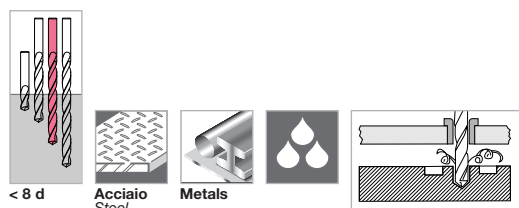

Velocità di taglio consigliata / Recommended cutting speed  
Acciaio / Steel - 10 m/min

Taglio dei materiali con  $R \leq 800 \text{ N/mm}^2$  quali acciai legati, ghise, tutti i metalli in genere, la grafite. Precisione di foratura e costanza di rendimenti elevati. High precision and high performances in cutting alloy steel up to  $R \leq 800 \text{ N/mm}^2$  / Puor percer métaux et acier avec  $R \leq 800 \text{ N/mm}^2$  / Para taladrar hierro e acero  $R \leq 800 \text{ N/mm}^2$  / Einsatz in Stahl und Stahlguss, legiert und unlegiert bis  $R \leq 800 \text{ N/mm}^2$  Zug-Festigkeit, Ne-Metalle, Kunststoffe

# 01098

## Punte elicoidali cilindriche, serie extra lunga, interamente rettificate

Extra long straight shank twist drills / Forets helicoidaux, série extra longue

Brocas helicoidales, serie extra larga / Spiralbohrer, extra lange Ausführung

HSS

DIN  
1869/1



d ≥ 3mm

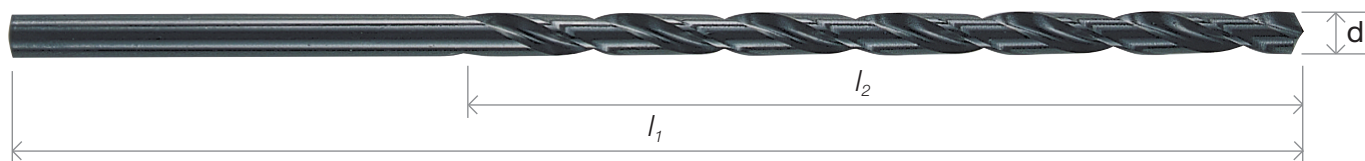

d h8	$l_2$	$l_1$		cod.	€ cad/each
2	85	125	1	010980200	8,446
2,5	95	140	1	010980250	8,870
3	100	150	1	010980300	9,822
3,5	115	165	1	010980350	10,422
4	120	175	1	010980400	10,422
4,5	125	185	1	010980450	11,333
5	135	195	1	010980500	11,333
5,25	135	195	1	010980525	13,766
5,5	140	205	1	010980550	13,766
5,75	140	205	1	010980575	13,766
6	140	205	1	010980600	13,766
6,5	150	215	1	010980650	16,415
7	155	225	1	010980700	18,951

d h8	$l_2$	$l_1$		cod.	€ cad/each
7,5	155	225	1	010980750	21,435
8	165	240	1	010980800	23,453
8,5	165	240	1	010980850	24,623
9	175	250	1	010980900	31,133
9,5	175	250	1	010980950	33,876
10	185	265	1	010981000	33,876
10,5	185	265	1	010981050	33,876
11	195	280	1	010981100	33,876
11,5	195	280	1	010981150	42,683
12	205	295	1	010981200	42,683
12,5	205	295	1	010981250	44,702
13	205	295	1	010981300	44,702

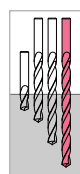

< 10 d



Acciaio  
Steel



Metals

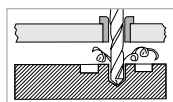

Velocità di taglio consigliata / Recommended cutting speed  
Acciaio / Steel - 10 m/min

Taglio dei materiali con  $R \leq 800$  N/mm<sup>2</sup> quali acciai legati, ghise, tutti i metalli in genere, la grafite. Precisione di foratura e costanza di rendimenti elevati. High precision and high performances in cutting alloy steel up to  $R \leq 800$  N/mm<sup>2</sup> / Puor percer métaux et acier avec  $R \leq 800$  N/mm<sup>2</sup> / Para taladrar hierro e acero  $R \leq 800$  N/mm<sup>2</sup> / Einsatz in Stahl und Stahlguss, legiert und unlegiert bis  $R \leq 800$  N/mm<sup>2</sup> Zug-Festigkeit, Ne-Metalle, Kunststoffe

## 01099

### Punte elicoidali cilindriche, serie extra lunga, interamente rettificate

Extra long straight shank twist drills / Forets helicoidaux, série extra longue

Brocas helicoidales, serie extra larga / Spiralbohrer, extra lange Ausführung

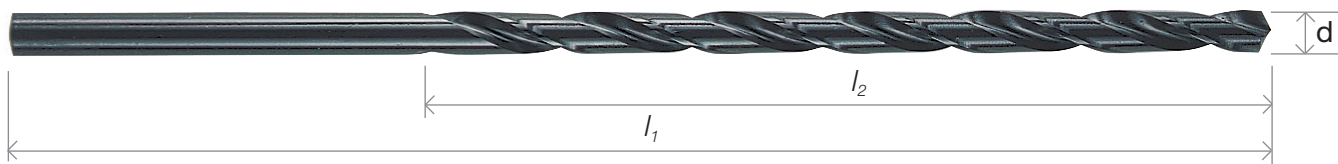
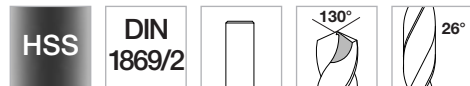

d	$l_2$	$l_1$		cod.	€ cad/each	d	$l_2$	$l_1$		cod.	€ cad/each
h8						h8					
3	130	190	1	010990300	12,078	8,5	210	305	1	010990850	38,109
3,5	145	210	1	010990350	12,544	9	220	320	1	010990900	45,343
4	150	220	1	010990400	12,969	9,5	220	320	1	010990950	45,892
4,5	160	235	1	010990450	14,987	10	235	340	1	010991000	45,892
5	170	245	1	010990500	15,401	10,5	235	340	1	010991050	47,631
5,5	180	260	1	010990550	20,120	11	250	365	1	010991100	47,631
6	180	260	1	010990600	20,120	11,5	250	365	1	010991150	50,022
6,5	190	275	1	010990650	21,435	12	260	375	1	010991200	60,020
7	200	290	1	010990700	24,871	12,5	260	375	1	010991250	63,011
7,5	200	290	1	010990750	28,587	13	260	375	1	010991300	63,011
8	210	305	1	010990800	29,115						

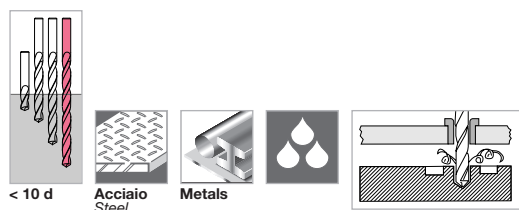

Velocità di taglio consigliata / Recommended cutting speed  
Acciaio / Steel - 10 m/min

Taglio dei materiali con  $R \leq 800 \text{ N/mm}^2$  quali acciai legati, ghise, tutti i metalli in genere, la grafite. Precisione di foratura e costanza di rendimenti elevati. High precision and high performances in cutting alloy steel up to  $R \leq 800 \text{ N/mm}^2$  / Puor percer métaux et acier avec  $R \leq 800 \text{ N/mm}^2$  / Para taladrar hierro e acero  $R \leq 800 \text{ N/mm}^2$  / Einsatz in Stahl und Stahlguss, legiert und unlegiert bis  $R \leq 800 \text{ N/mm}^2$  Zug-Festigkeit, Ne-Metalle, Kunststoffe

# 01100

## Punte elicoidali cilindriche, serie extra lunga, interamente rettificate

Extra long straight shank twist drills / Forets helicoidaux, série extra longue

Brocas helicoidales, serie extra larga / Spiralbohrer, extra lange Ausführung

HSS

DIN  
1869/3

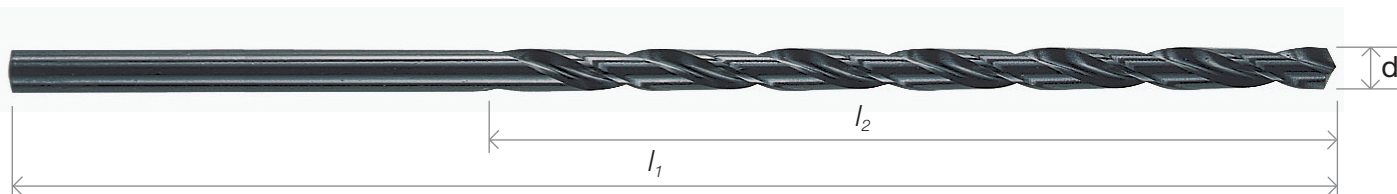

d h8	$l_2$	$l_1$		cod.	€ cad/each
3,5	180	265	1	011000350	15,846
4	190	280	1	011000400	15,277
4,5	200	295	1	011000450	18,206
5	210	315	1	011000500	18,982
5,5	225	330	1	011000550	20,379
6	225	330	1	011000600	21,300
6,5	235	350	1	011000650	23,619
7	250	370	1	011000700	30,574
7,5	250	370	1	011000750	34,735
8	265	390	1	011000800	34,735

d h8	$l_2$	$l_1$		cod.	€ cad/each
8,5	265	390	1	011000850	45,385
9	280	410	1	011000900	49,090
9,5	280	410	1	011000950	53,261
10	295	430	1	011001000	53,261
10,5	295	430	1	011001050	53,261
11	310	455	1	011001100	53,261
11,5	310	455	1	011001150	55,931
12	330	480	1	011001200	67,109
12,5	330	480	1	011001250	77,511
13	330	480	1	011001300	77,511

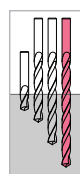

< 10 d



Acciaio  
Steel



Metals

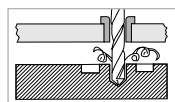

Velocità di taglio consigliata / Recommended cutting speed  
Acciaio / Steel - 10 m/min

Taglio dei materiali con  $R \leq 800 \text{ N/mm}^2$  quali acciai legati, ghise, tutti i metalli in genere, la grafite. Precisione di foratura e costanza di rendimenti elevati. High precision and high performances in cutting alloy steel up to  $R \leq 800 \text{ N/mm}^2$  / Puor percer métaux et acier avec  $R \leq 800 \text{ N/mm}^2$  / Para taladrar hierro e acero  $R \leq 800 \text{ N/mm}^2$  / Einsatz in Stahl und Stahlguss, legiert und unlegiert bis  $R \leq 800 \text{ N/mm}^2$  Zug-Festigkeit, Ne-Metalle, Kunststoffe

## 01370

### Punte elicoidali cilindriche, serie extra lunga, interamente rettificate

Extra long straight shank twist drills / Forets helicoidaux, série extra longue

Brocas helicoidales, serie extra larga / Spiralbohrer, extra lange Ausführung

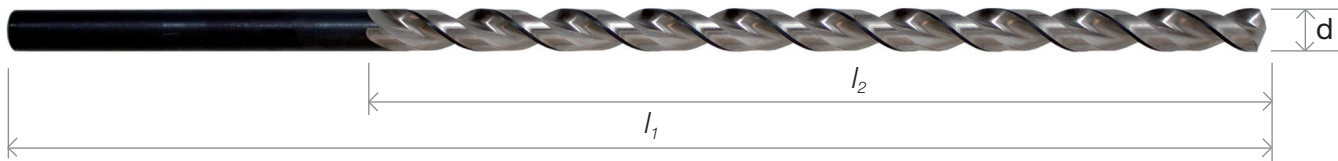
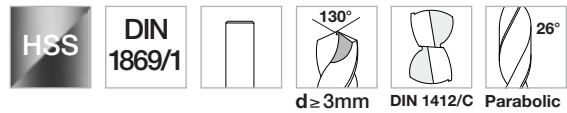

d	$l_2$	$l_1$		cod.	€ cad/each
h8					
2	85	125	1	013700200	14,718
2,5	95	140	1	013700250	15,463
3	100	150	1	013700300	17,233
3,5	115	165	1	013700350	17,792
4	120	175	1	013700400	18,071
4,5	125	185	1	013700450	20,120
5	135	195	1	013700500	20,586
5,25	135	195	1	013700525	23,474
5,5	140	205	1	013700550	23,474
5,75	140	205	1	013700575	23,474
6	140	205	1	013700600	23,474
6,5	150	215	1	013700650	29,342
7	155	225	1	013700700	33,534

d	$l_2$	$l_1$		cod.	€ cad/each
h8					
7,5	155	225	1	013700750	39,589
8	165	240	1	013700800	42,942
8,5	165	240	1	013700850	55,331
9	175	250	1	013700900	58,685
9,5	175	250	1	013700950	67,068
10	185	265	1	013701000	62,038
10,5	185	265	1	013701050	74,427
11	195	280	1	013701100	83,462
11,5	195	280	1	013701150	91,194
12	205	295	1	013701200	110,290
12,5	205	295	1	013701250	115,692
13	205	295	1	013701300	111,035

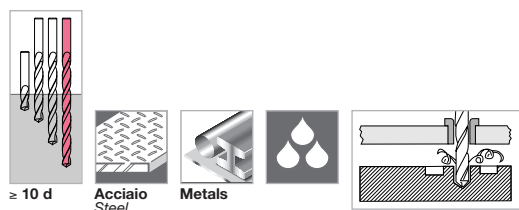

Velocità di taglio consigliata / Recommended cutting speed  
Acciaio / Steel - 10 m/min

Taglio dei materiali con  $R \leq 800 \text{ N/mm}^2$  quali acciai legati, ghise, tutti i metalli in genere, la grafite. Precisione di foratura e costanza di rendimenti elevati. High precision and high performances in cutting alloy steel up to  $R \leq 800 \text{ N/mm}^2$  / Puor percer métaux et acier avec  $R \leq 800 \text{ N/mm}^2$  / Para taladrar hierro e acero  $R \leq 800 \text{ N/mm}^2$  / Einsatz in Stahl und Stahlguss, legiert und unlegiert bis  $R \leq 800 \text{ N/mm}^2$  Zug-Festigkeit, Ne-Metalle, Kunststoffe

# 01371

## Punte elicoidali cilindriche, serie extra lunga, interamente rettificate

Extra long straight shank twist drills / Forets helicoidaux, série extra longue

Brocas helicoidales, serie extra larga / Spiralbohrer, extra lange Ausführung

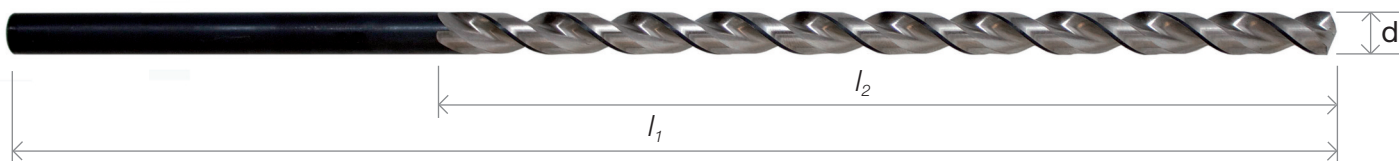
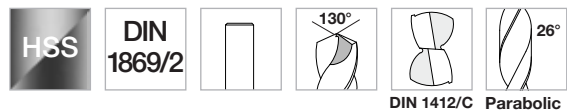

d h8	$l_2$	$l_1$		cod.	€ cad/each
3	130	190	1	013710300	19,976
3,5	145	210	1	013710350	21,207
4	150	220	1	013710400	21,383
4,5	160	235	1	013710450	25,958
5	170	245	1	013710500	24,985
5,5	180	260	1	013710550	33,255
6	180	260	1	013710600	32,468
6,5	190	275	1	013710650	36,422
7	200	290	1	013710700	41,172
7,5	200	290	1	013710750	49,090
8	210	305	1	013710800	49,090

d h8	$l_2$	$l_1$		cod.	€ cad/each
8,5	210	305	1	013710850	66,509
9	220	320	1	013710900	68,093
9,5	220	320	1	013710950	80,761
10	235	340	1	013711000	77,594
10,5	235	340	1	013711050	101,347
11	250	365	1	013711100	116,220
11,5	250	365	1	013711150	129,499
12	260	375	1	013711200	130,472
12,5	260	375	1	013711250	138,121
13	260	375	1	013711300	136,185

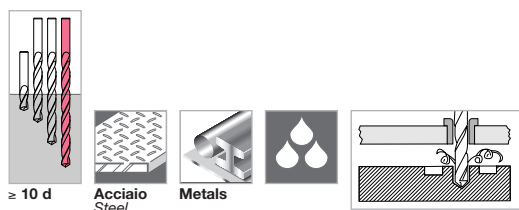

Velocità di taglio consigliata / Recommended cutting speed  
Acciaio / Steel - 10 m/min

Taglio dei materiali con  $R \leq 800 \text{ N/mm}^2$  quali acciai legati, ghise, tutti i metalli in genere, la grafite. Precisione di foratura e costanza di rendimenti elevati. High precision and high performances in cutting alloy steel up to  $R \leq 800 \text{ N/mm}^2$  / Puor percer métaux et acier avec  $R \leq 800 \text{ N/mm}^2$  / Para taladrar hierro e acero  $R \leq 800 \text{ N/mm}^2$  / Einsatz in Stahl und Stahlguss, legiert und unlegiert bis  $R \leq 800 \text{ N/mm}^2$  Zug-Festigkeit, Ne-Metalle, Kunststoffe

## 01372

### Punte elicoidali cilindriche, serie extra lunga, interamente rettificate

Extra long straight shank twist drills / Forets helicoidaux, série extra longue

Brocas helicoidales, serie extra larga / Spiralbohrer, extra lange Ausführung

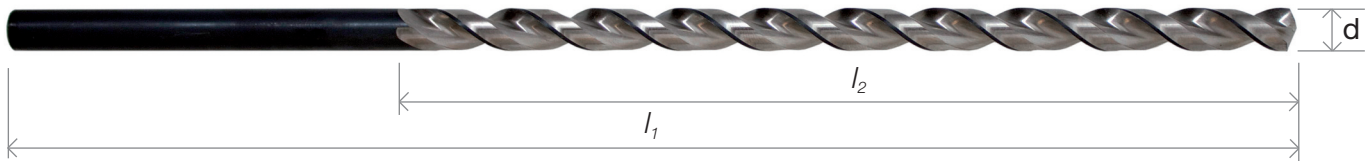
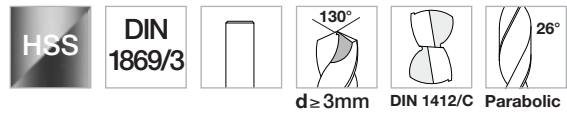

d	l <sub>2</sub>	l <sub>1</sub>		cod.	€ cad/each	d	l <sub>2</sub>	l <sub>1</sub>		cod.	€ cad/each
h8						h8					
3,5	180	265	1	013720350	31,857	8,5	265	390	1	013720850	93,895
4	190	280	1	013720400	31,857	9	280	410	1	013720900	103,955
4,5	200	295	1	013720450	40,241	9,5	280	410	1	013720950	115,692
5	210	315	1	013720500	40,241	10	295	430	1	013721000	115,692
5,5	225	330	1	013720550	42,942	10,5	295	430	1	013721050	121,374
6	225	330	1	013720600	43,594	11	310	455	1	013721100	138,514
6,5	235	350	1	013720650	48,624	11,5	310	455	1	013721150	148,854
7	250	370	1	013720700	63,715	12	330	480	1	013721200	155,281
7,5	250	370	1	013720750	72,098	12,5	330	480	1	013721250	159,659
8	265	390	1	013720800	73,775	13	330	480	1	013721300	159,659

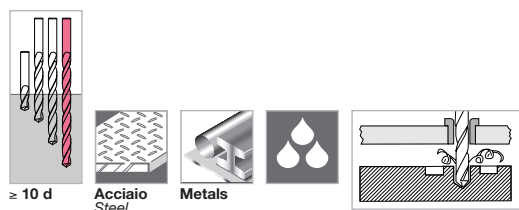

**Velocità di taglio consigliata / Recommended cutting speed**  
**Acciaio / Steel - 10 m/min**

Taglio dei materiali con  $R \leq 800 \text{ N/mm}^2$  quali acciai legati, ghise, tutti i metalli in genere, la grafite. Precisione di foratura e costanza di rendimenti elevati. High precision and high performances in cutting alloy steel up to  $R \leq 800 \text{ N/mm}^2$  / Puor percer métaux et acier avec  $R \leq 800 \text{ N/mm}^2$  / Para taladrar hierro e acero  $R \leq 800 \text{ N/mm}^2$  / Einsatz in Stahl und Stahlguss, legiert und unlegiert bis  $R \leq 800 \text{ N/mm}^2$  Zug-Festigkeit, Ne-Metalle, Kunststoffe

# 01105

## Punte elicoidali cilindriche HSS rettificate, serie speciali super lunghe

HSS fully ground twist drills with special extra length / Forets helicoidaux rectifié, série extra longue speciaux

Brocas rectificadas, serie extra larga especial / Geschliffene Spiralbohrer, lange Ausführung

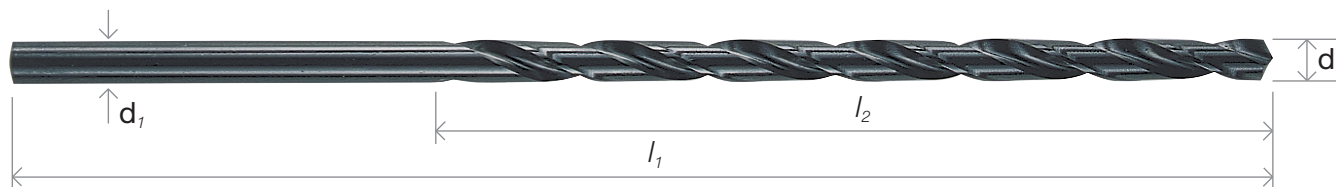
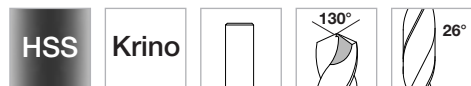

d	$l_2$	$l_1$	$d_1$		cod.	€ cad/each	d	$l_2$	$l_1$	$d_1$		cod.	€ cad/each
6	228	305	6	1	011050600	25,523	10,5	228	305	10,5	1	011051050	57,763
6,5	228	305	6,5	1	011050650	28,214	11	228	305	11	1	011051100	57,763
7	228	305	7	1	011050700	36,266	11,5	228	305	11,5	1	011051150	59,782
7,5	228	305	7,5	1	011050750	41,648	12	228	305	12	1	011051200	59,782
8	228	305	8	1	011050800	45,675	12,5	228	305	12,5	1	011051250	62,690
8,5	228	305	8,5	1	011050850	54,410	13	228	305	13	1	011051300	62,690
9	228	305	9	1	011050900	54,410	14	228	305	13	1	011051400	77,915
9,5	228	305	9,5	1	011050950	56,418	15	228	305	13	1	011051500	89,600
10	228	305	10	1	011051000	56,418	16	228	305	13	1	011051600	99,971

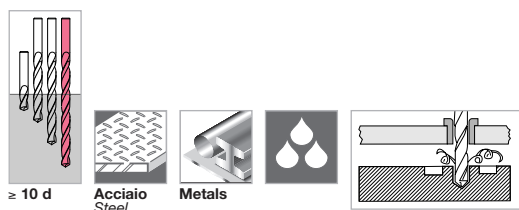

Velocità di taglio consigliata / Recommended cutting speed  
Acciaio / Steel - 10 m/min

Taglio dei materiali con  $R \leq 800 \text{ N/mm}^2$  quali acciai legati, ghise, tutti i metalli in genere, la grafite. Precisione di foratura e costanza di rendimenti elevati. High precision and high performances in cutting alloy steel up to  $R \leq 800 \text{ N/mm}^2$  / Puor percer métaux et acier avec  $R \leq 800 \text{ N/mm}^2$  / Para taladrar hierro e acero  $R \leq 800 \text{ N/mm}^2$  / Einsatz in Stahl und Stahlguss, legiert und unlegiert bis  $R \leq 800 \text{ N/mm}^2$  Zug-Festigkeit, Ne-Metalle, Kunststoffe



## 01114

**Punte elicoidali cilindriche HSS rettificate, serie speciali super lunghe**  
 HSS fully ground twist drills with special extra length / Forets helicoidaux rectifié, série extra longue speciaux  
 Brocas rectificadas, serie extra larga especial / Geschliffene Spiralbohrer, lange Ausführung

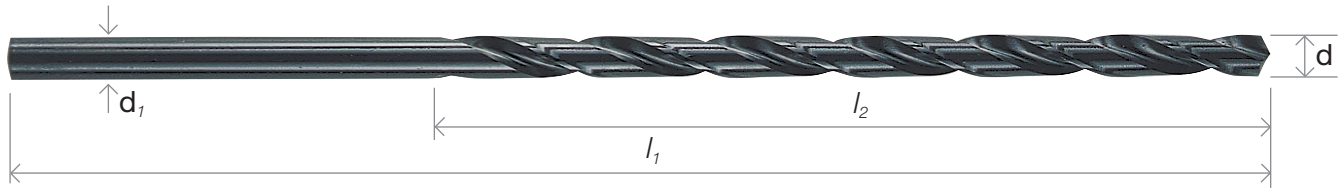
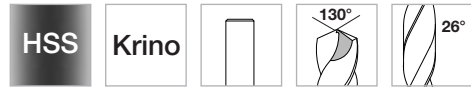

d	$l_2$	$l_1$	$d_1$		cod.	€ cad/each
6	330	460	6	1	011140600	34,455
8	330	460	8	1	011140800	55,093
10	330	460	10	1	011141000	79,747
12	330	460	12	1	011141200	108,882
14	330	460	13	1	011141400	152,249
16	330	460	13	1	011141600	190,305

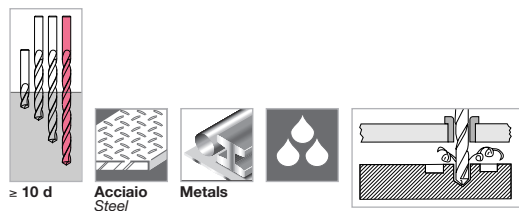

**Velocità di taglio consigliata / Recommended cutting speed**  
**Acciaio / Steel - 10 m/min**

Taglio dei materiali con  $R \leq 800 \text{ N/mm}^2$  quali acciai legati, ghise, tutti i metalli in genere, la grafite. Precisione di foratura e costanza di rendimenti elevati. High precision and high performances in cutting alloy steel up to  $R \leq 800 \text{ N/mm}^2$  / Puor percer métaux et acier avec  $R \leq 800 \text{ N/mm}^2$  / Para taladrar hierro e acero  $R \leq 800 \text{ N/mm}^2$  / Einsatz in Stahl und Stahlguss, legiert und unlegiert bis  $R \leq 800 \text{ N/mm}^2$  Zug-Festigkeit, Ne-Metalle, Kunststoffe

# 01093

## Punte elicoidali con placchetta in metallo duro K20 per il taglio dei metalli

Carbide tipped twist drills for metal cutting / Forets à mise rapportée carbure de tungstène pour métaux  
 Brocas helicoidales, corte de metal duro para acero / Spiralbohrer mit Schneidplatte aus Hartmetall für Metall

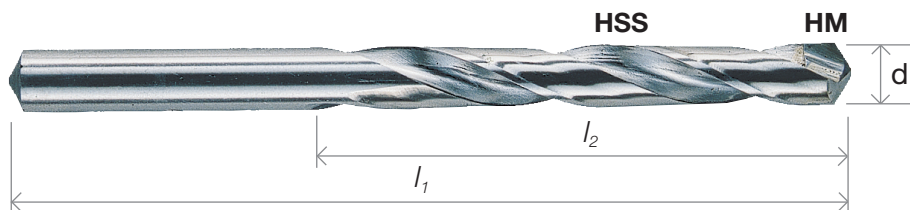
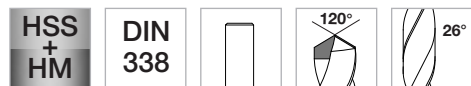

d	$l_2$	$l_1$		cod.	€ cad/each
2	24	49	1	010930200	28,576
2,5	30	57	1	010930250	28,576
3	33	61	1	010930300	28,576
3,5	39	70	1	010930350	28,576
4	43	75	1	010930400	15,877
4,5	47	80	1	010930450	16,550
5	52	86	1	010930500	17,543
5,5	57	93	1	010930550	18,206
6	57	93	1	010930600	18,868
6,5	63	101	1	010930650	20,845
7	69	109	1	010930700	21,176
7,5	69	109	1	010930750	22,491

d	$l_2$	$l_1$		cod.	€ cad/each
8	75	117	1	010930800	24,488
8,5	75	117	1	010930850	28,121
9	81	125	1	010930900	28,121
9,5	81	125	1	010930950	30,108
10	87	133	1	010931000	32,416
10,5	87	133	1	010931050	35,076
11	94	142	1	010931100	37,726
11,5	94	142	1	010931150	41,017
12	101	151	1	010931200	44,319
12,5	101	151	1	010931250	47,631
13	101	151	1	010931300	51,595

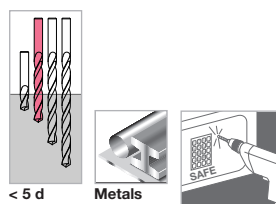

Taglio degli acciai duri trattati ed abrasivi con R da 750 N/mm<sup>2</sup> a 1400 N/mm<sup>2</sup>, acciai per molle, acciai al manganese, molibdeno puro, ghisa in conchiglia con HB>300, bronzo duro. / For drilling in: Hardened steel, tough cast iron, manganese steel, bronze, abrasive tough steel. / Pour percer: acier traité et au manganese, font, acier abrasif. / Para taladar: metales muy abrasivos, aceros tratados, acero manganese, bronzo duro. / Spiralbohrer nach dieser Norm eignen sich zum Bohren von Stahl mit 750 bis 1400 N/mm<sup>2</sup> (~75 bis 140 N/mm<sup>2</sup>) Zugfestigkeit sowie für Gußeisen, Hartguß, Temperguß, Rotguß, Bronze und Stahlguß.

## 01092

### Punte per alluminio e per materiali a truciolo lungo, serie corta

Fully ground twist drills for light alloys / Forets rectifiés pour aluminium et alliage léger

Brocas rectificadas para aluminio y aleaciones ligeras / Geschliffene Spiralbohrer für Aluminium und Leichtmetalllegierung

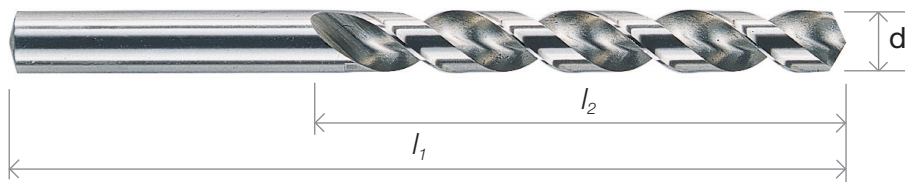
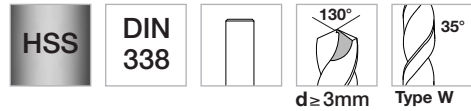

d	l <sub>2</sub>	l <sub>1</sub>		cod.	€ cad/each	d	l <sub>2</sub>	l <sub>1</sub>		cod.	€ cad/each
1	12	34	10	010920100	3,943	6,25	63	101	10	010920625	9,884
1,5	18	40	10	010920150	3,498	6,5	63	101	10	010920650	8,994
2	24	49	10	010920200	3,498	6,75	69	109	10	010920675	10,050
2,25	27	53	10	010920225	4,005	7	69	109	10	010920700	9,139
2,5	30	57	10	010920250	3,571	7,25	69	109	5	010920725	15,090
2,75	33	61	10	010920275	4,326	7,5	69	109	5	010920750	15,090
3	33	61	10	010920300	3,933	7,75	75	117	5	010920775	16,808
3,2	36	65	10	010920320	4,761	8	75	117	5	010920800	16,136
3,25	36	65	10	010920325	4,761	8,25	75	117	5	010920825	16,374
3,5	39	70	10	010920350	4,326	8,5	75	117	5	010920850	15,132
3,75	39	70	10	010920375	5,175	8,75	81	125	5	010920875	17,109
4	43	75	10	010920400	4,689	9	81	125	5	010920900	15,639
4,2	43	75	10	010920420	6,407	9,25	81	125	5	010920925	17,833
4,25	43	75	10	010920425	6,407	9,5	81	125	5	010920950	17,109
4,5	47	80	10	010920450	5,672	9,75	87	133	5	010920975	18,930
4,75	47	80	10	010920475	6,479	10	87	133	5	010921000	17,460
5	52	86	10	010920500	5,827	10,5	87	133	5	010921050	21,238
5,2	52	86	10	010920520	8,259	11	94	142	5	010921100	25,803
5,25	52	86	10	010920525	8,259	11,5	94	142	5	010921150	30,294
5,5	57	93	10	010920550	7,866	12	101	151	5	010921200	33,120
5,75	57	93	10	010920575	8,259	12,5	101	151	5	010921250	34,476
6	57	93	10	010920600	7,504	13	101	151	5	010921300	34,476

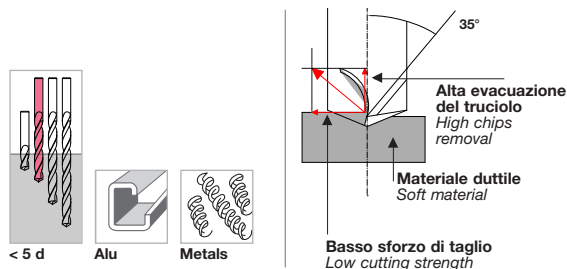

**Velocità di taglio consigliata / Recommended cutting speed**  
**Alluminio / Aluminium - 40 m/min**  
**Leghe di alluminio / Aluminium alloys - 30 m/min**



19 pcs - Ø 1÷10x0,5  
**01068303 € 153,366**

25 pcs - Ø 1÷13 x 0,5 mm  
**01068304 € 315,685**

L'alluminio puro ha una lavorabilità eccellente, ma crea trucioli estremamente lunghi e continui. L'elica di tipo W a 35° agevola l'evacuazione di tali trucioli, evitando intasamenti nella zona di taglio. Le leghe di alluminio hanno invece una migliore resistenza meccanica e una lavorabilità buona, che peggiora all'aumentare del contenuto di silicio in lega. Le leghe di alluminio trovano impiego in applicazioni strutturali nell'industria automobilistica e aeronautica, apparecchiature mobili, condotti e accessori, unità idrauliche ad alta pressione, apparecchiature marine. Aluminium is easily workable, but it produces very long chip. W type 35° flute of this drill makes this chip easily removable. Aluminium alloys have a better mechanical resistance; the more Si is included, the less workable they are. They're used in structural application of automotive and aeronautic industry, moving devices, pipes and accessories, high pressure tanks, marine devices.

# 01091

## Punte per ottone e per materiali a truciolo corto, serie corta

Fully ground twist drills for brass / Forets rectifiés pour laiton  
Brocas rectificadas para latón / Geschliffene Spiralbohrer für Messing

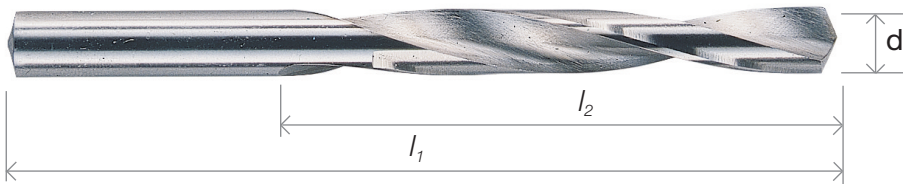
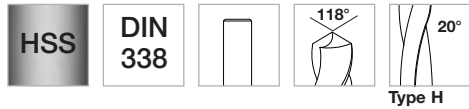

d h8	l <sub>2</sub>	l <sub>1</sub>		cod.	€ cad/each
1	12	34	10	010910100	3,943
1,5	18	40	10	010910150	3,498
2	24	49	10	010910200	3,498
2,25	27	53	10	010910225	4,005
2,5	30	57	10	010910250	3,571
2,75	33	61	10	010910275	4,326
3	33	61	10	010910300	3,933
3,25	36	65	10	010910325	4,761
3,5	39	70	10	010910350	4,326
3,75	39	70	10	010910375	5,175
4	43	75	10	010910400	4,689
4,25	43	75	10	010910425	6,407
4,5	47	80	10	010910450	5,672
4,75	47	80	10	010910475	6,479
5	52	86	10	010910500	5,827
5,25	52	86	10	010910525	8,259
5,5	57	93	10	010910550	7,866
5,75	57	93	10	010910575	8,259
6	57	93	10	010910600	7,504
6,25	63	101	10	010910625	9,884
6,5	63	101	10	010910650	8,944

d h8	l <sub>2</sub>	l <sub>1</sub>		cod.	€ cad/each
6,75	69	109	10	010910675	10,050
7	69	109	10	010910700	9,139
7,25	69	109	5	010910725	15,090
7,5	69	109	5	010910750	15,090
7,75	75	117	5	010910775	16,808
8	75	117	5	010910800	16,136
8,25	75	117	5	010910825	16,374
8,5	75	117	5	010910850	15,132
8,75	81	125	5	010910875	17,109
9	81	125	5	010910900	15,639
9,25	81	125	5	010910925	17,833
9,5	81	125	5	010910950	17,109
9,75	87	133	5	010910975	18,930
10	87	133	5	010911000	17,460
10,5	87	133	5	010911050	21,238
11	94	142	5	010911100	25,803
11,5	94	142	5	010911150	30,294
12	101	151	5	010911200	33,120
12,5	101	151	5	010911250	34,476
13	101	151	5	010911300	34,476

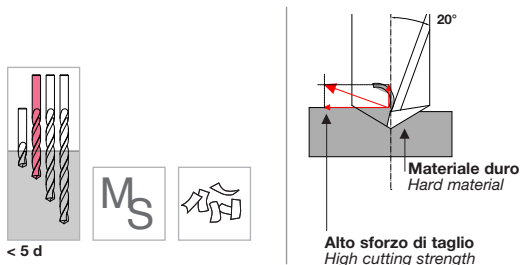

**Velocità di taglio consigliata /**  
Recommended cutting speed  
**Bronzi / Bronze - 15 m/min**  
**Ottone / Brass - 30 m/min**



19 pcs - Ø 1÷10x0,5  
**01068305 € 153,366**  
25 pcs - Ø 1÷13 x 0,5 mm  
**01068306 € 315,685**

Le leghe in rame, come bronzi e ottone, hanno buona lavorabilità. L'elica ampia di tipo H a 20° favorisce l'evacuazione dei trucioli spezzettati di lavorazione. Le leghe in rame hanno impieghi principalmente in componenti elettrici, elettronici, attrezzature per costruzioni, particolari di serrature, valvole per auto, micromeccanica. Copper alloys, like brass and bronze, are easily workable. Type H 20° flute of this drill makes this chip easily removable. Copper alloys are used in electrical and electronic devices, construction tools, locks, car valves, micromechanical components.

## 01090

### Punte elicoidali cilindriche sinistre, interamente rettificate

Straight shank twist drills, left hand / Forets helicoidaux, coupe à gauche

Brocas helicoidales izquierdas / Spiralbohrer mit Zylinderschaft, link

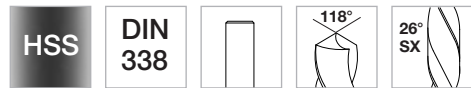

## SINISTRE/LEFT HAND

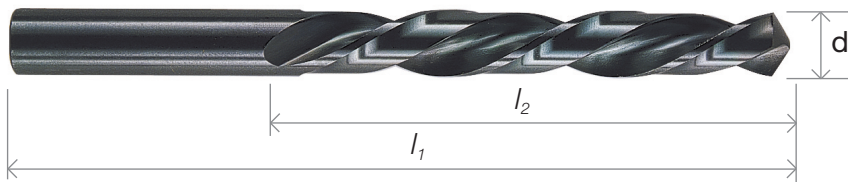

d	l <sub>2</sub>	l <sub>1</sub>		cod.	€ cad/each
1	12	34	10	010900100	3,105
1,5	18	40	10	010900150	2,453
2	24	49	10	010900200	2,453
2,2	27	53	10	010900220	2,453
2,5	30	57	10	010900250	2,453
2,8	33	61	10	010900280	2,453
3	33	61	10	010900300	2,453
3,2	36	65	10	010900320	3,012
3,5	39	70	10	010900350	3,012
3,8	43	75	10	010900380	3,312
4	43	75	10	010900400	3,312
4,1	43	75	10	010900410	3,809
4,2	43	75	10	010900420	3,809
4,5	47	80	10	010900450	3,809
4,8	52	86	10	010900480	4,119
5	52	86	10	010900500	4,119
5,2	52	86	10	010900520	5,579

d	l <sub>2</sub>	l <sub>1</sub>		cod.	€ cad/each
5,5	57	93	10	010900550	5,579
5,8	57	93	10	010900580	6,107
6	57	93	10	010900600	6,107
6,5	63	101	10	010900650	7,411
7	69	109	10	010900700	8,901
7,5	69	109	5	010900750	10,050
8	75	117	5	010900800	10,795
8,5	75	117	5	010900850	11,406
9	81	125	5	010900900	14,004
9,5	81	125	5	010900950	15,121
10	87	133	5	010901000	16,601
10,5	87	133	5	010901050	20,855
11	94	142	5	010901100	24,436
11,5	94	142	5	010901150	25,575
12	101	151	5	010901200	28,328
12,5	101	151	5	010901250	30,895
13	101	151	5	010901300	31,547

Decimali su richiesta  
Decimal sizes on demand

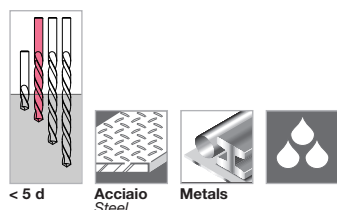

Velocità di taglio consigliata / Recommended cutting speed  
Acciaio / Steel - 10 m/min

Taglio dei materiali con R ≤ 800 N/mm<sup>2</sup> quali acciai legati, ghise, tutti i metalli in genere, la grafite. Precisione di foratura e costanza di rendimenti elevati. High precision and high performances in cutting alloy steel up to R ≤ 800 N/mm<sup>2</sup> / Puor percer métaux et acier avec R ≤ 800 N/mm<sup>2</sup> / Para taladrar hierro e acero R ≤ 800 N/mm<sup>2</sup> / Einsatz in Stahl und Stahlguss, legiert und unlegiert bis R ≤ 800 N/mm<sup>2</sup> Zug-Festigkeit, Ne-Metalle, Kunststoffe



19 pcs - Ø 1÷10x0,5  
01068309 € 134,333  
25 pcs - Ø 1÷13 x 0,5 mm  
01068310 € 283,228

# 01067

## Punte elicoidali cilindriche sinistre, interamente rettificate, serie extra corta

Straight shank twist drills, left hand, stub serie / Forets helicoidaux, coupe à gauche, série extra courte

Brocas helicoidales izquierdas, serie extra corta / Spiralbohrer mit Zylinderschaft, link, extra Kurz

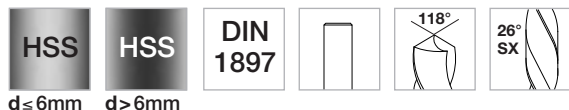

### SINISTRE/LEFT HAND

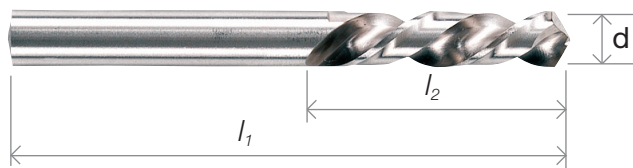

d	l <sub>2</sub>	l <sub>1</sub>		cod.	€ cad/each
1,5	9	32	10	010670150	19,437
2	12	38	10	010670200	11,923
2,2	13	40	10	010670220	22,604
2,5	14	43	10	010670250	16,394
2,7	16	46	10	010670270	39,620
2,8	16	46	10	010670280	26,517
3	16	46	10	010670300	8,321
3,1	18	49	10	010670310	17,450
3,2	18	49	10	010670320	28,690
3,25	18	49	10	010670325	37,074
3,5	20	52	10	010670350	17,326
3,7	20	52	10	010670370	24,716
3,75	20	52	10	010670375	24,095
3,8	22	55	10	010670380	25,896
4	22	55	10	010670400	9,936
4,2	22	55	10	010670420	12,855
4,5	24	58	10	010670450	25,213
4,8	26	62	10	010670480	36,763
5	26	62	10	010670500	18,382
5,1	26	62	10	010670510	23,660
5,2	26	62	10	010670520	26,827
5,5	28	66	10	010670550	22,480

d	l <sub>2</sub>	l <sub>1</sub>		cod.	€ cad/each
5,7	28	66	10	010670570	46,265
5,8	28	66	10	010670580	38,564
6	28	66	10	010670600	12,855
6,5	31	70	10	010670650	31,982
7	34	74	10	010670700	17,512
7,5	34	74	5	010670750	23,350
8	37	79	5	010670800	19,934
8,5	37	79	5	010670850	26,827
9	40	84	5	010670900	30,429
9,5	40	84	5	010670950	42,352
10	43	89	5	010671000	23,101
10,2	43	89	5	010671020	43,470
10,5	43	89	5	010671050	45,209
11	47	95	5	010671100	50,984
11,5	47	95	5	010671150	78,991
12	51	102	5	010671200	34,652
12,5	51	102	5	010671250	63,218
13	51	102	5	010671300	46,575
14	54	107	3	010671400	62,411
15	56	111	3	010671500	85,077
16	58	115	3	010671600	77,811

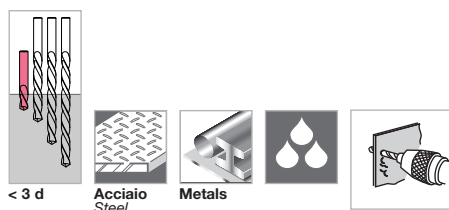

Velocità di taglio consigliata / Recommended cutting speed  
Acciaio / Steel - 10 m/min

Taglio degli acciai duri trattati ed abrasivi con R da 750 N/mm<sup>2</sup> a 1400 N/mm<sup>2</sup>, acciai per molle, acciai al manganese, molibdeno puro, ghisa in conchiglia con HB>300, bronzo duro. / For drilling in: Hardened steel, tough cast iron, manganese steel, bronze, abrasive tough steel. / Pour percer: acier traité et au manganese, font, acier abrasif. / Para taladar: metales muy abrasivos, aceros tratados, acero manganese, bronzo duro. / Spiralbohrer nach dieser Norm eignen sich zum Bohren von Stahl mit 750 bis 1400 N/mm<sup>2</sup> (~75 bis 140 Kp/mm<sup>2</sup>) Zugfestigkeit sowie für Gußeisen, Hartguß, Temperguß, Rotguß, Bronze und Stahlguß.

## 01050

### Punte elicoidali supercorte per lamiera, speciali per lattonieri

Extra short twist drills for portable applications / Forets cylindriques série extra courte spécial  
 Brocas helicoidales, serie extra corta special / Spiralbohrer, spezial extra kurz

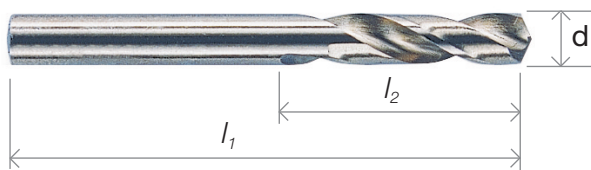
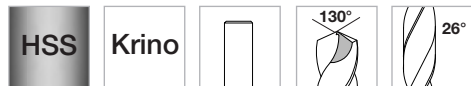

d	l <sub>2</sub>	l <sub>1</sub>		cod.	€ cad/each
3	16	35	10	010500300	0,869
3,2	19	40	10	010500320	0,911
3,25	19	40	10	010500325	0,911
3,3	19	40	10	010500330	0,911
3,5	19	40	10	010500350	0,911
3,6	19	40	10	010500360	1,004
3,75	19	40	10	010500375	1,004
4	20	40	10	010500400	1,004
4,1	20	40	10	010500410	1,232
4,25	20	40	10	010500425	1,232
4,5	23	42	10	010500450	1,232
5	23	45	10	010500500	1,346

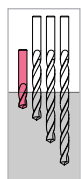

< 3 d



Acciaio  
Steel



CuZnNiMs



Alu



Velocità di taglio consigliata / Recommended cutting speed  
 Acciaio / Steel - 10 m/min

Punte speciali per lattonieri, carpentieri, coperturisti, fabbri, installatori. Foratura dolce e precisa, grazie all'affilatura split point autocentrante, su lamiera e tubi in acciaio, rame e plastica. / Super short twist drills for cutting metal sheets, special for journeymen's, carpenters, locksmith's, tinsmith's. / Forets spéciaux pour les plombiers zingueurs, les charpentiers, les couvreurs, les menuisiers, les installateurs. / Un perçage doux et précis, grâce à un affutage split point auto centreur, sur des tôles et des tubes en acier, cuivre et plastique. / Brocas especiales para estañeros, herreros, hojalateros, cerrajeros e instaladores. Perforado suave y preciso gracias al afilado del tipo split point de autocentrado en planchas y tubos de acero, latón y plástico. / Spezielle Bohrer für Klempner, Zimmerer, Metallbearbeiter, Schlosser, Installateure. Sanfte und präzise Bohrung dank des selbstzentrierenden Kreuzanschliffs auf Blechen und Rohren aus Stahl, Kupfer und Kunststoff.

# 01079

## Punte elicoidali interamente rettificate con attacco HEX 1/4", serie corta.

Fully ground 1/4" Q.C. twist drills / Forets rectifiés avec 1/4" Q.C. queue

Brocas rectificadas con mango 1/4" Q.C. / Geschliffene Spiralbohrer mit 1/4" Q.C. Shaft

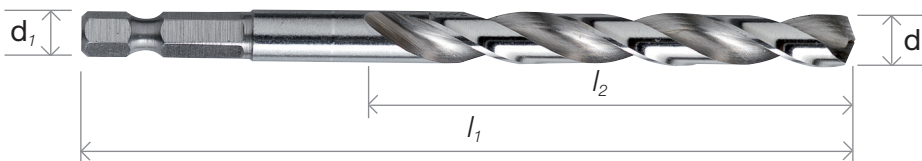
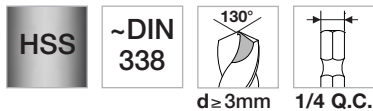

d h8	d <sub>1</sub> ○	l <sub>2</sub>	l <sub>1</sub>	pcs 	cod.	€ cad/each
1,5	1/4	18	60	10	010790150	1,273
2	1/4	24	69	10	010790200	1,273
2,5	1/4	30	77	10	010790250	1,325
3	1/4	33	81	10	010790300	1,656
3,25	1/4	36	85	10	010790325	1,760
3,5	1/4	39	90	10	010790350	1,760
4	1/4	43	95	10	010790400	1,925
4,25	1/4	43	95	10	010790425	2,256
4,5	1/4	47	100	10	010790450	2,256
5	1/4	52	106	10	010790500	2,422
5,5	1/4	57	113	10	010790550	2,919
6	1/4	57	113	10	010790600	3,240
6,5	1/4	63	121	10	010790650	4,337
7	1/4	69	109	10	010790700	5,020
7,5	1/4	69	109	5	010790750	6,469
8	1/4	75	117	5	010790800	6,469
8,5	1/4	75	117	5	010790850	8,052
9	1/4	81	125	5	010790900	9,356
9,5	1/4	81	125	5	010790950	10,309
10	1/4	87	133	5	010791000	10,681

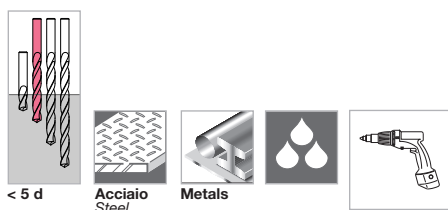

**Velocità di taglio consigliata / Recommended cutting speed**  
**Acciaio / Steel - 10 m/min**



Ø 3-4-5-6-8 mm  
**01068700 € 20,700**

Taglio dei materiali con R ≤ 800 N/mm<sup>2</sup> quali acciai legati, ghise, tutti i metalli in genere, la grafite. Precisione di foratura e costanza di rendimenti elevati. High precision and high performances in cutting alloy steel up to R ≤ 800 N/mm<sup>2</sup> / Puor percer métaux et acier avec R ≤ 800 N/mm<sup>2</sup> / Para taladrar hierro e acero R ≤ 800 N/mm<sup>2</sup> / Einsatz in Stahl und Stahlguss, legiert und unlegiert bis R ≤ 800 N/mm<sup>2</sup> Zug-Festigkeit, Ne-Metalle, Kunststoffe



## 01110

### Punte a centrare, angolo di svasatura 60°

Center drills 60° / Forets à centrer 60°

Brocas de centrar 60° / Zentrierbohrer 60°

**HSS** **DIN 333A**

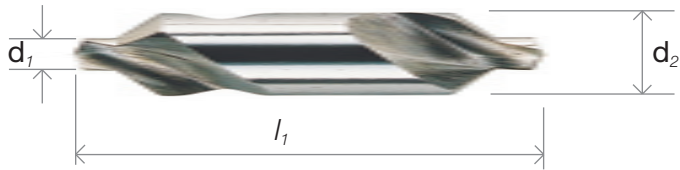

$d_1$	$d_2$	$l_1$		cod.	€ cad/each	$d_1$	$d_2$	$l_1$		cod.	€ cad/each
<b>1</b>	3,15	31,5	1	011100100	<b>5,061</b>	<b>3,15</b>	8	50	1	011100315	<b>6,614</b>
1,6	4	35,5	1	011100160	4,958	4	10	56	1	011100400	12,917
<b>2</b>	5	40	1	011100200	<b>5,247</b>	<b>5</b>	12,5	63	1	011100500	<b>17,533</b>
2,5	6,3	45	1	011100250	5,651	6,3	16	71	1	011100630	29,498

## 01374

**HSS** **~DIN 333A**

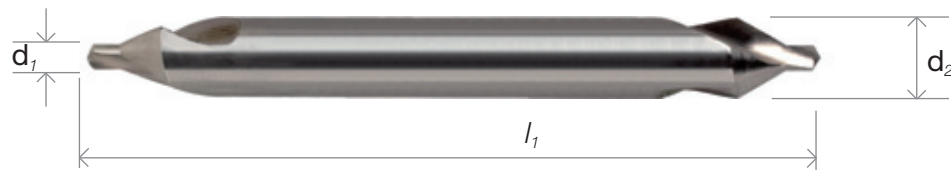

$d_1$	$d_2$	$l_1$		cod.	€ cad/each
<b>1</b>	4	120	1	013740100	<b>23,267</b>
1,6	5	120	1	013740160	23,267
<b>2</b>	6	120	1	013740200	<b>23,267</b>
2,5	8	120	1	013740250	25,337
<b>3,15</b>	10	120	1	013740315	<b>49,111</b>

# 01375

## Punte a centrare con pianetto, angolo di svasatura 60°

Center drill 60° / Forets à centrer 60°  
Brocas de centrar 60° / Zentrierbohrer 60°

HSS

~DIN  
333A



$d_1$	$d_2$	$l_1$	S		cod.	€ cad/each
1,6	4	35,5	3,25	1	013750160	14,190
2	5	40	4,2	1	013750200	14,190
2,5	6,3	45	5,35	1	013750250	14,190
3,15	8	50	6,95	1	013750315	17,978
4	10	56	8,4	1	013750400	25,337
5	12,5	63	10,95	1	013750500	38,771
6,3	16	71	14	1	013750630	68,238

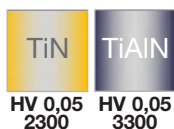

Rivestimento TiN-TiAlN disponibile su richiesta  
TiN-TiAlN coating available on demand



Le punte a centrare permettono un perfetto centraggio: grazie alla loro geometria, resistono molto bene alla flessione e producono fori svasati. Agevolano così la successiva fase di foratura o l'utilizzo su tornio con idonee contropunte, al fine di ottenere lavorazioni perfettamente coaxiali. / Center drills can stand the bending and torsion moment during the operations, thanks to their special geometry. They produce flaring holes. They ease the drilling phase and make the hole coaxial to the center drill itself. / Les forets à centrer permettent un centrage parfait : grâce à leur forme, ils sont très résistants à la flexion et produisent des trous fraisés. Ils facilitent ainsi la phase suivante de perçage ou l'utilisation sur un tour avec les contrepointes appropriées, afin d'obtenir des usinages parfaitement coaxiaux. / Las puntas que hay que centrar permiten un centrado perfecto: gracias a su geometría, resisten muy bien a la flexión y producen orificios cóncavos. De esta forma facilitan la sucesiva fase de perforado o el uso en un torno con las contrapuntas idóneas, para obtener resultados perfectamente coaxiales. / Die Zentrierbohrer erlauben eine perfekte Zentrierung: dank ihrer Geometrie sind sie sehr biegesteif und produzieren Ziehsenklöcher. So vereinfachen sie die Bohrphase oder die Verwendung auf einer Drehmaschine mit geeigneten Gegenspitzen, um perfekt koaxiale Bearbeitungen zu erzielen.

## 01112

### Punte a centrare, angolo di svasatura 60°-120°

Center drills 60°-120° / Forets à centrer 60°-120°

Brocas de centrar 60°-120° / Zentrierbohrer 60°-120°

HSS

DIN  
333B

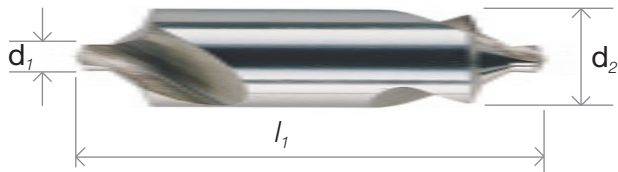

$d_1$	$d_2$	$l_1$		cod.	€ cad/each
1	4	35,5	1	011120100	7,721
1,6	6,3	45	1	011120160	8,456
2	8	50	1	011120200	9,129
2,5	10	56	1	011120250	11,654
3,15	11,2	60	1	011120315	14,004
4	14	67	1	011120400	22,159
5	18	75	1	011120500	27,862
6,3	20	80	1	011120630	40,862

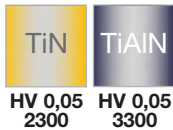

Rivestimento TiN-TiAlN disponibile su richiesta  
TiN-TiAlN coating available on demand

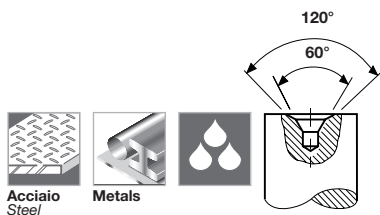

Le punte a centrare permettono un perfetto centraggio: grazie alla loro geometria, resistono molto bene alla flessione e producono fori svasati. Agevolano così la successiva fase di foratura o l'utilizzo su tornio con idonee contropunte, al fine di ottenere lavorazioni perfettamente coassiali. / Center drills can stand the bending and torsion moment during the operations, thanks to their special geometry. They produce flaring holes. They ease the drilling phase and make the hole coaxial to the center drill itself. / Les forets à centrer permettent un centrage parfait : grâce à leur forme, ils sont très résistants à la flexion et produisent des trous fraisés. Ils facilitent ainsi la phase suivante de perçage ou l'utilisation sur un tour avec les contrepointes appropriées, afin d'obtenir des usinages parfaitement coaxiaux. / Las puntas que hay que centrar permiten un centrado perfecto: gracias a su geometría, resisten muy bien a la flexión y producen orificios cóncavos. De esta forma facilitan la sucesiva fase de perforado o el uso en un torno con las contrapuntas idóneas, para obtener resultados perfectamente coaxiales. / Die Zentrierbohrer erlauben eine perfekte Zentrierung: dank ihrer Geometrie sind sie sehr biegesteif und produzieren Ziehsenklöcher. So vereinfachen sie die Bohrphase oder die Verwendung auf einer Drehmaschine mit geeigneten Gegenspitzen, um perfekt koaxiale Bearbeitungen zu erzielen.

# 01111

## Punte a centrare a raggio, angolo di svasatura 60°

Center drills 60° / Forets à centrer 60°

Brocas de centrar 60° / Zentrierbohrer 60°

HSS

DIN  
333R

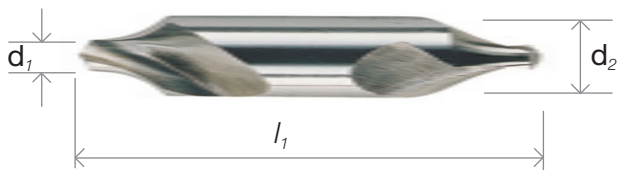

$d_1$	$d_2$	$l_1$		cod.	€ cad/each
1	3,15	31,5	1	011110100	5,061
1,6	4	35,5	1	011110160	4,958
2	5	40	1	011110200	5,247
2,5	6,3	45	1	011110250	5,651
3,15	8	50	1	011110315	6,614
4	10	56	1	011110400	12,917
5	12,5	63	1	011110500	17,533
6,3	16	71	1	011110630	29,498



HV 0,05  
2300

HV 0,05  
3300

Rivestimento TiN-TiAlN disponibile su richiesta  
*TiN-TiAlN coating available on demand*

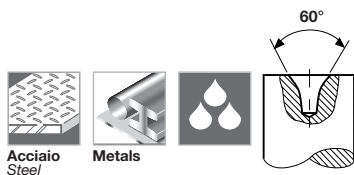

Le punte a centrare permettono un perfetto centraggio: grazie alla loro geometria, resistono molto bene alla flessione e producono fori svasati. Agevolano così la successiva fase di foratura o l'utilizzo su tornio con idonee contropunte, al fine di ottenere lavorazioni perfettamente coassiali. / Center drills can stand the bending and torsion moment during the operations, thanks to their special geometry. They produce flaring holes. They ease the drilling phase and make the hole coaxial to the center drill itself. / Les forets à centrer permettent un centrage parfait : grâce à leur forme, ils sont très résistants à la flexion et produisent des trous fraisés. Ils facilitent ainsi la phase suivante de perçage ou l'utilisation sur un tour avec les contrepontes appropriées, afin d'obtenir des usinages parfaitement coaxiaux. / Las puntas que hay que centrar permiten un centrado perfecto: gracias a su geometría, resisten muy bien a la flexión y producen orificios cóncavos. De esta forma facilitan la sucesiva fase de perforado o el uso en un torno con las contrapuntas idóneas, para obtener resultados perfectamente coaxiales. / Die Zentrierbohrer erlauben eine perfekte Zentrierung: dank ihrer Geometrie sind sie sehr biegesteif und produzieren Ziehsenklöcher. So vereinfachen sie die Bohrphase oder die Verwendung auf einer Drehmaschine mit geeigneten Gegenspitzen, um perfekt koaxiale Bearbeitungen zu erzielen.

## 01364

### Punte a centrare cilindriche per centri CNC-90°

CNC center drills / Forêts à center pour machines CNC

Brocas de centrar para CNC / CNC Zentrierbohrer

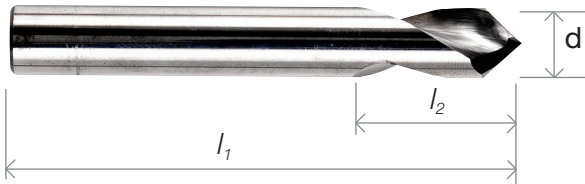

d	$l_2$	$l_1$		cod.	€ cad/each
3	12	46	1	013640300	12,544
4	12	55	1	013640400	13,414
5	14	62	1	013640500	15,090
6	16	66	1	013640600	17,450
8	21	79	1	013640800	26,393
10	25	89	1	013641000	33,410
12	30	102	1	013641200	47,196
14	33	107	1	013641400	67,379
16	37	115	1	013641600	73,464
20	45	131	1	013642000	125,628



Acciaio  
Steel

Metals

# 01365

## Punte a centrare cilindriche per centri CNC-120°

CNC center drills / Forêts à center pour machines CNC

Brocas de centrar para CNC / CNC Zentrierbohrer

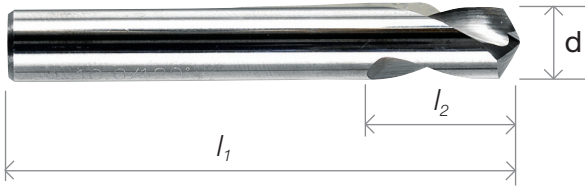

d	$l_2$	$l_1$		cod.	€ cad/each
3	12	46	1	013650300	12,544
4	12	55	1	013650400	13,414
5	14	62	1	013650500	15,090
6	16	66	1	013650600	17,450
8	21	79	1	013650800	26,393
10	25	89	1	013651000	33,410
12	30	102	1	013651200	47,196
14	33	107	1	013651400	67,379
16	37	115	1	013651600	73,464
20	45	131	1	013652000	125,628



Acciaio  
Steel

Metals

## 01103

### Punte a gradino ad eliche indipendenti per fori sedi di viti

Subland twist drills with independent spirals for screws holes / Forets étagés avec hélices indépendantes, pour têtes de vis  
 Brocas escalonadas con espirales independientes, para asientos de tornillos / Stufenbohrer mit selbständigen Schrauben für Zylinderschrauben

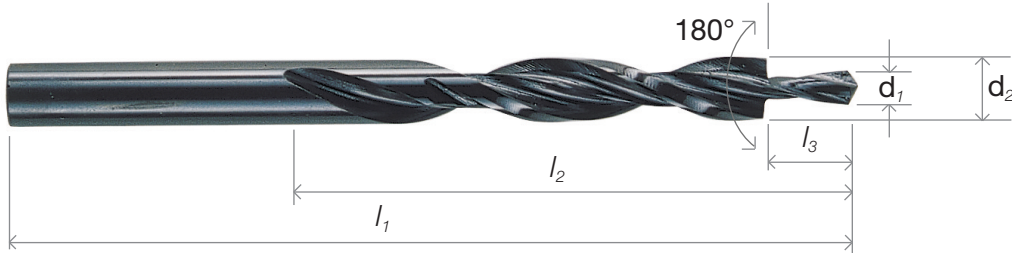
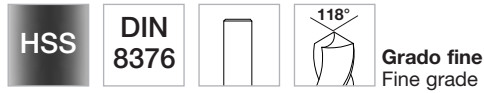

VITE thread	d <sub>1</sub>	d <sub>2</sub>	l <sub>3</sub>	l <sub>2</sub>	l <sub>1</sub>		cod.	€ cad/each
<b>M 3</b>	3,4	6	9	57	93	1	011030300	<b>33,079</b>
4	4,5	8	11	75	117	1	011030400	<b>37,219</b>
<b>5</b>	5,5	10	13	87	133	1	011030500	<b>45,499</b>
6	6,6	11	15	94	142	1	011030600	<b>53,758</b>
<b>8</b>	9,0	15	19	114	169	1	011030800	<b>66,985</b>
10	11	18	23	130	191	1	011031000	<b>100,085</b>

Per fori passanti - For through holes - Pour trous débouchants  
 Para orificios pasantes - Für Durchgangslöcher

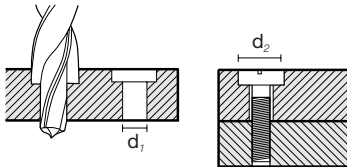

**Velocità di taglio consigliata / Recommended cutting speed**  
**Acciaio / Steel - 10 m/min**  
**Leghe di alluminio / Aluminium alloys - 30 m/min**

Taglio dei materiali con R ≤ 800 N/mm<sup>2</sup> quali acciai legati, ghise, tutti i metalli in genere, la grafite. Precisione di foratura e costanza di rendimenti elevati.  
 High precision and high performances in cutting alloy steel up to R ≤ 800 N/mm<sup>2</sup> / Puor percer métaux et acier avec R ≤ 800 N/mm<sup>2</sup> / Para taladrar hierro e acero R ≤ 800 N/mm<sup>2</sup> / Einsatz in Stahl und Stahlguss, legiert und unlegiert bis R ≤ 800 N/mm<sup>2</sup> Zug-Festigkeit, Ne-Metalle, Kunststoffe

# 01104

## Punte a gradino ad eliche indipendenti per fori sedi di viti

Subland twist drills with independent spirals for screws holes / Forets étagés avec hélices indépendantes, pour têtes de vis  
 Brocas escalonadas con espirales independientes, para asientos de tornillos / Stufenbohrer mit selbständigen Schrauben für Zylinderschrauben

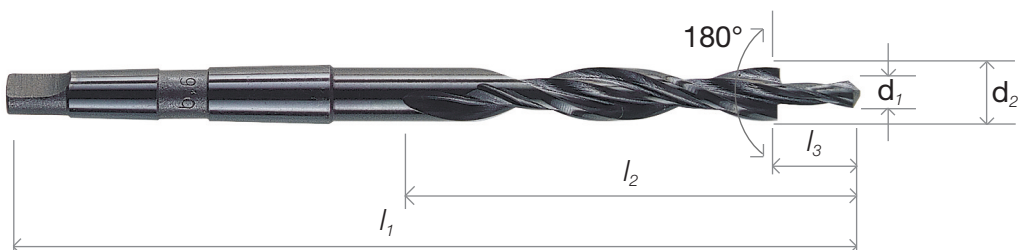
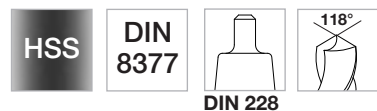

VITE thread	d <sub>1</sub>	d <sub>2</sub>	l <sub>3</sub>	l <sub>2</sub>	l <sub>1</sub>	M.K.		cod.	€ cad/each
<b>M 5</b>	5,5	10	13	87	168	1	1	011040500	<b>67,389</b>
6	6,6	11	15	94	175	1	1	011040600	<b>70,753</b>
<b>8</b>	9,0	15	19	114	212	2	1	011040800	<b>95,261</b>
10	11	18	23	130	228	2	1	011041000	<b>125,380</b>
<b>12</b>	13,5	20	27	140	238	2	1	011041200	<b>155,602</b>
14	15,5	24	31	160	281	3	1	011041400	<b>190,305</b>
<b>16</b>	17,5	26	35	165	286	3	1	011041600	<b>223,891</b>
18	20	30	39	175	296	3	1	011041800	<b>259,713</b>
<b>20</b>	22	33	43	185	334	4	1	011042000	<b>302,251</b>

Per fori passanti - For through holes - Pour trous débouchants  
 Para orificios pasantes - Für Durchgangslöcher

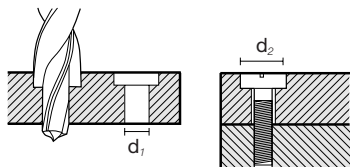

**Velocità di taglio consigliata / Recommended cutting speed**  
**Acciaio / Steel - 10 m/min**  
**Leghe di alluminio / Aluminium alloys - 30 m/min**

Taglio dei materiali con  $R \leq 800 \text{ N/mm}^2$  quali acciai legati, ghise, tutti i metalli in genere, la grafite. Precisione di foratura e costanza di rendimenti elevati.  
 High precision and high performances in cutting alloy steel up to  $R \leq 800 \text{ N/mm}^2$  / Puor percer métaux et acier avec  $R \leq 800 \text{ N/mm}^2$  / Para taladrar hierro e acero  
 $R \leq 800 \text{ N/mm}^2$  / Einsatz in Stahl und Stahlguss, legiert und unlegiert bis  $R \leq 800 \text{ N/mm}^2$  Zug-Festigkeit, Ne-Metalle, Kunststoffe





## 01101

### Punte a gradino ad eliche indipendenti per fori sedi di viti

Subland twist drills with independent spirals for screws holes / Forets étagés avec hélices indépendantes, pour têtes de vis  
 Brocas escalonadas con espirales independientes, para asientos de tornillos / Stufenbohrer mit selbständigen Schrauben für Zylinderschrauben

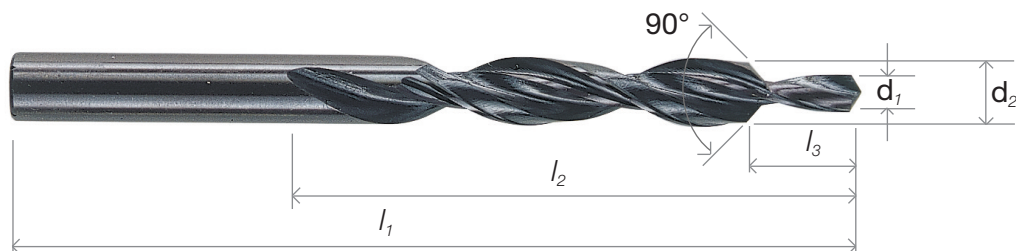
**HSS** **DIN 8374**  **Grado fine**  
 Fine grade



VITE thread	d <sub>1</sub>	d <sub>2</sub>	l <sub>3</sub>	l <sub>2</sub>	l <sub>1</sub>		cod.	€ cad/each
<b>M 3</b>	3,2	6	9	57	93	1	011010300	<b>37,602</b>
4	4,3	8	11	75	117	1	011010400	<b>43,128</b>
<b>5</b>	5,3	10	13	87	133	1	011010500	<b>54,441</b>
6	6,4	11,5	15	94	142	1	011010600	<b>62,669</b>
<b>8</b>	8,4	15	19	114	169	1	011010800	<b>106,129</b>
10	10,5	19	23	135	198	1	011011000	<b>164,565</b>

Per fori passanti - For through holes - Pour trous débouchants  
 Para orificios pasantes - Für Durchgangslöcher

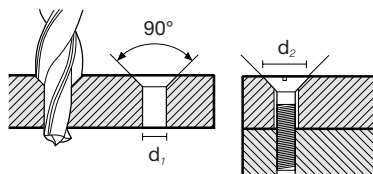

**Velocità di taglio consigliata / Recommended cutting speed**  
**Acciaio / Steel - 10 m/min**  
**Leghe di alluminio / Aluminium alloys - 30 m/min**

Taglio dei materiali con R ≤ 800 N/mm<sup>2</sup> quali acciai legati, ghise, tutti i metalli in genere, la grafite. Precisione di foratura e costanza di rendimenti elevati.  
 High precision and high performances in cutting alloy steel up to R ≤ 800 N/mm<sup>2</sup> / Puor percer métaux et acier avec R ≤ 800 N/mm<sup>2</sup> / Para taladrar hierro e acero R ≤ 800 N/mm<sup>2</sup> / Einsatz in Stahl und Stahlguss, legiert und unlegiert bis R ≤ 800 N/mm<sup>2</sup> Zug-Festigkeit, Ne-Metalle, Kunststoffe

# 01102

## Punte a gradino ad eliche indipendenti per fori sedi di viti

Subland twist drills with independent spirals for screws holes / Forets étagés avec hélices indépendantes, pour têtes de vis  
 Brocas escalonadas con espirales independientes, para asientos de tornillos / Stufenbohrer mit selbständigen Schrauben für Zylinderschrauben

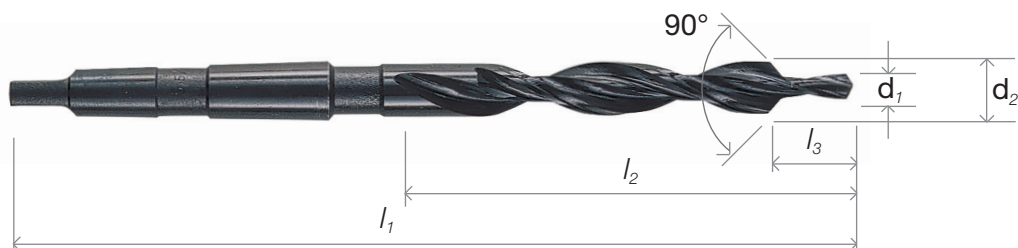
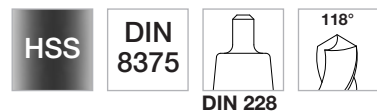

VITE thread	d <sub>1</sub>	d <sub>2</sub>	l <sub>3</sub>	l <sub>2</sub>	l <sub>1</sub>	M.K.		cod.	€ cad/each
M 5	5,5	11	13	94	175	1	1	011020500	73,040
6	6,6	13	15	101	182	1	1	011020600	98,149
8	9,0	17,2	19	130	228	2	1	011020800	125,380
10	11	21,5	23	150	248	2	1	011021000	173,518

Per fori passanti - For through holes - Pour trous débouchants  
 Para orificios pasantes - Für Durchgangslöcher

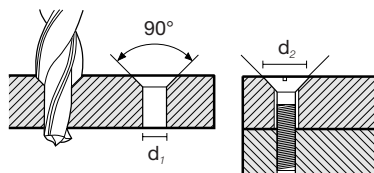

**Velocità di taglio consigliata / Recommended cutting speed**  
**Acciaio / Steel - 10 m/min**  
**Leghe di alluminio / Aluminium alloys - 30 m/min**

Taglio dei materiali con R ≤ 800 N/mm<sup>2</sup> quali acciai legati, ghise, tutti i metalli in genere, la grafite. Precisione di foratura e costanza di rendimenti elevati.  
 High precision and high performances in cutting alloy steel up to R ≤ 800 N/mm<sup>2</sup> / Puor percer métaux et acier avec R ≤ 800 N/mm<sup>2</sup> / Para taladrar hierro e acero R ≤ 800 N/mm<sup>2</sup> / Einsatz in Stahl und Stahlguss, legiert und unlegiert bis R ≤ 800 N/mm<sup>2</sup> Zug-Festigkeit, Ne-Metalle, Kunststoffe

## 01117

### Punta a gradino ad eliche indipendenti per prefiori di filettatura

Subland twist drills with independent spirals for thread core hole / Foret étagés avec hélices indépendantes pour trous de taraudage  
 Brocas escalonadas con espirales independientes para orificios de roscado / Stufenbohrer mit selbständigen Schrauben für Gewindelöcher

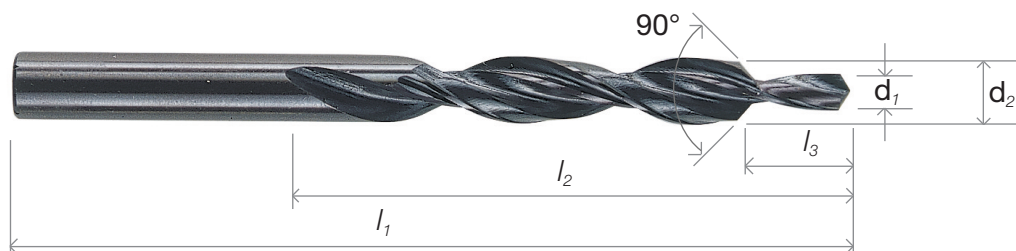
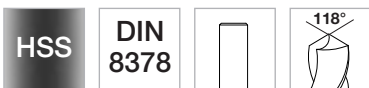

VITE thread	d <sub>1</sub>	d <sub>2</sub>	l <sub>3</sub>	l <sub>2</sub>	l <sub>1</sub>		cod.	€ cad/each
<b>M 3</b>	2,5	3,4	8,8	39	70	1	011170300	42,125
4	3,3	4,5	11,4	47	80	1	011170400	44,940
<b>5</b>	4,2	5,5	13,6	57	93	1	011170500	46,347
6	5	6,6	16,5	63	101	1	011170600	53,365
<b>8</b>	6,8	9,0	21	81	125	1	011170800	60,382
10	8,5	11	25,5	94	142	1	011171000	78,639
<b>12</b>	10,2	13,5	30	108	160	1	011171200	102,506

Per prefiori di filettature - For thread core holes - Pour trous de taraudage  
 Para orificios de roscado - Für Gewindelöcher

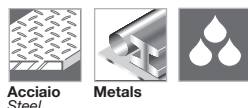
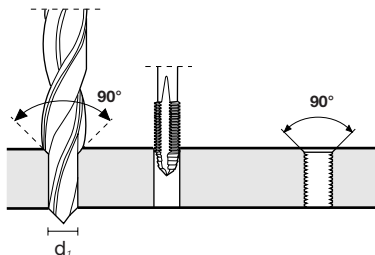

**Velocità di taglio consigliata / Recommended cutting speed**  
**Acciaio / Steel - 10 m/min**

Taglio dei materiali con R ≤ 800 N/mm<sup>2</sup> quali acciai legati, ghise, tutti i metalli in genere, la grafite. Precisione di foratura e costanza di rendimenti elevati.  
 High precision and high performances in cutting alloy steel up to R ≤ 800 N/mm<sup>2</sup> / Puor percer métaux et acier avec R ≤ 800 N/mm<sup>2</sup> / Para taladrar hierro e acero  
 R ≤ 800 N/mm<sup>2</sup> / Einsatz in Stahl und Stahlguss, legiert und unlegiert bis R ≤ 800 N/mm<sup>2</sup> Zug-Festigkeit, Ne-Metalle, Kunststoffe

# 01059

## Punte a gradino ad elica singola per sedi di viti, serie corta

Subland twist drills, short serie / Forets étagés, série courte  
 Brocas escalonadas, serie corta / Stufenbohrer, Kurze Ausführung



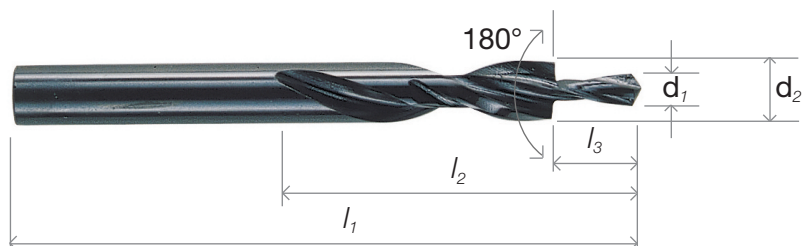

**HSS**    **~DIN 8376**     **Grado fine**  
 Fine grade

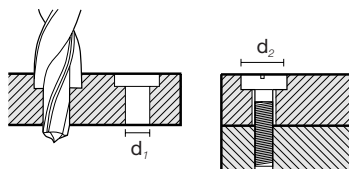

VITE thread	d <sub>1</sub>	d <sub>2</sub>	l <sub>3</sub>	l <sub>2</sub>	l <sub>1</sub>		cod.	€ cad/each
<b>M 3</b>	3,4	6	9	28	66	1	010590300	15,411
4	4,5	8	11	37	79	1	010590400	19,272
<b>5</b>	5,5	10	13	43	89	1	010590500	28,908
6	6,6	11	15	47	95	1	010590600	42,394
<b>8</b>	9,0	15	19	56	111	1	010590800	61,655
10	11,0	18	23	62	123	1	010591000	96,348

Per fori passanti - For through holes - Pour trous débouchants  
 Para orificios pasantes - Für Durchgangslöcher



 **Acciaio** / Steel     **Metals**     **Alu**     **Velocità di taglio consigliata / Recommended cutting speed**  
**Acciaio / Steel - 10 m/min**  
**Leghe di alluminio / Aluminium alloys - 30 m/min**

Taglio dei materiali con R ≤ 800 N/mm<sup>2</sup> quali acciai legati, ghise, tutti i metalli in genere, la grafite. Precisione di foratura e costanza di rendimenti elevati.  
 High precision and high performances in cutting alloy steel up to R ≤ 800 N/mm<sup>2</sup> / Puor percer métaux et acier avec R ≤ 800 N/mm<sup>2</sup> / Para taladrar hierro e acero R ≤ 800 N/mm<sup>2</sup> / Einsatz in Stahl und Stahlguss, legiert und unlegiert bis R ≤ 800 N/mm<sup>2</sup> Zug-Festigkeit, Ne-Metalle, Kunststoffe

## 01058

### Punte a gradino ad elica singola per sedi di viti, serie corta

Subland twist drills, short serie / Forets étagés, série courte

Brocas escalonadas, serie corta / Stufenbohrer, Kurze Ausführung

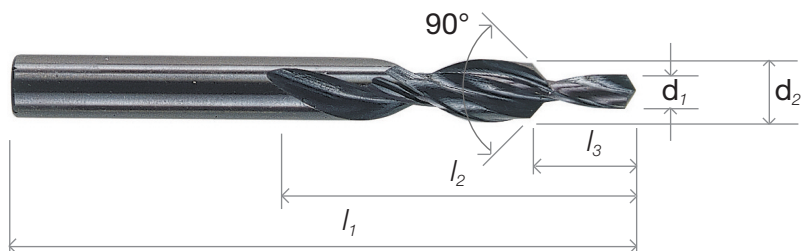
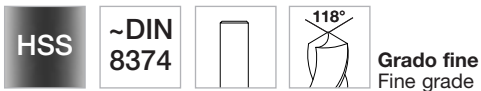

VITE thread	d <sub>1</sub>	d <sub>2</sub>	l <sub>3</sub>	l <sub>2</sub>	l <sub>1</sub>		cod.	€ cad/each
<b>M 3</b>	3,2	6	9	28	66	1	010580300	15,411
4	4,3	8	11	37	79	1	010580400	19,272
<b>5</b>	5,3	10	13	43	89	1	010580500	28,908
6	6,4	11,5	15	47	95	1	010580600	42,394
<b>8</b>	8,4	15	19	56	111	1	010580800	61,655
10	10,5	19	23	62	123	1	010581000	96,348

Per fori passanti - For through holes - Pour trous débouchants  
Para orificios pasantes - Für Durchgangslöcher

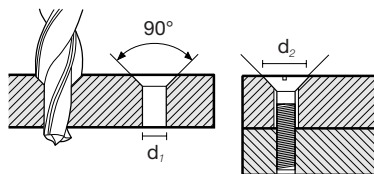

**Velocità di taglio consigliata / Recommended cutting speed**

**Acciaio / Steel - 10 m/min**

**Leghe di alluminio / Aluminium alloys - 30 m/min**

Taglio dei materiali con R ≤ 800 N/mm<sup>2</sup> quali acciai legati, ghise, tutti i metalli in genere, la grafite. Precisione di foratura e costanza di rendimenti elevati.  
High precision and high performances in cutting alloy steel up to R ≤ 800 N/mm<sup>2</sup> / Puor percer métaux et acier avec R ≤ 800 N/mm<sup>2</sup> / Para taladrar hierro e acero  
R ≤ 800 N/mm<sup>2</sup> / Einsatz in Stahl und Stahlguss, legiert und unlegiert bis R ≤ 800 N/mm<sup>2</sup> Zug-Festigkeit, Ne-Metalle, Kunststoffe

# 01057

## Punte a gradino ad elica singola, serie corta, per prefiori di filettatura

Subland twist drills, short serie / Forets étagés, série courte  
 Brocas escalonadas, serie corta / Stufenbohrer, Kurze Ausführung

HSS

~DIN  
8378

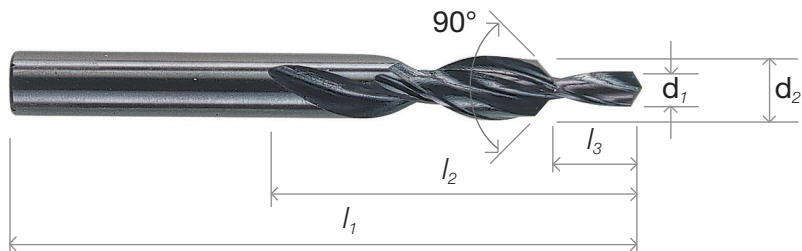
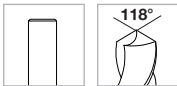

VITE thread	d <sub>1</sub>	d <sub>2</sub>	l <sub>3</sub>	l <sub>2</sub>	l <sub>1</sub>		cod.	€ cad/each
M 3	2,5	3,4	8,8	20	52	1	010570300	16,187
4	3,3	4,5	11,4	24	58	1	010570400	16,187
5	4,2	5,5	13,6	28	66	1	010570500	18,495
6	5,0	6,6	16,5	31	70	1	010570600	20,814
8	6,8	9,0	21,0	40	84	1	010570800	27,748
10	8,5	11,0	25,5	47	95	1	010571000	41,617
12	10,2	13,5	30,0	54	107	1	010571200	57,805

Per prefiori di filettature - For thread core holes - Pour trous de taraudage  
 Para orificios de rosca - Für Gewindelöcher

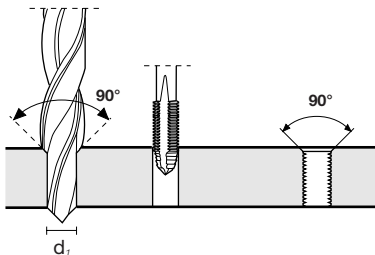

Acciaio  
Steel



Metals



Velocità di taglio consigliata / Recommended cutting speed  
 Acciaio / Steel - 10 m/min

Taglio dei materiali con  $R \leq 800 \text{ N/mm}^2$  quali acciai legati, ghise, tutti i metalli in genere, la grafite. Precisione di foratura e costanza di rendimenti elevati.  
 High precision and high performances in cutting alloy steel up to  $R \leq 800 \text{ N/mm}^2$  / Pour percer métaux et acier avec  $R \leq 800 \text{ N/mm}^2$  / Para taladrar hierro e acero  
 $R \leq 800 \text{ N/mm}^2$  / Einsatz in Stahl und Stahlguss, legiert und unlegiert bis  $R \leq 800 \text{ N/mm}^2$  Zug-Festigkeit, Ne-Metalle, Kunststoffe

## 01097

### Punte elicoidali codolo conico Morse, esecuzione fresata

Morse taper shank twist drills / Forets à queue conique morse

Brocas helicoidales con mango conico/ Spiralbohrer mit Morsekegel

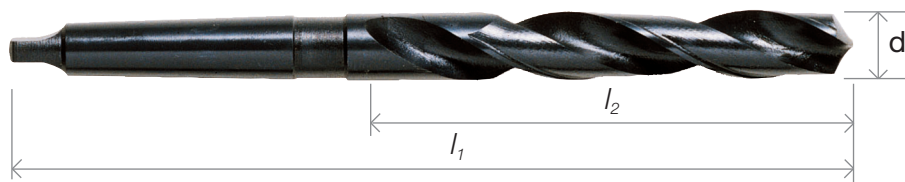
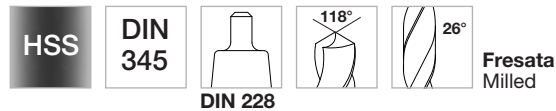

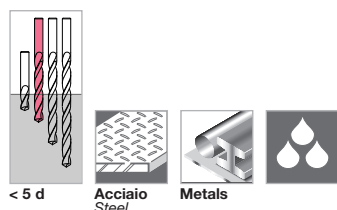

d	M.K.	$l_2$	$l_1$		cod.	€ cad/each	d	M.K.	$l_2$	$l_1$		cod.	€ cad/each
5	1	52	133	1	010970500	12,948	14,5	2	114	212	1	010971450	19,137
<b>6</b>	1	57	138	1	010970600	12,948	14,75	2	114	212	1	010971475	21,042
6,25	1	63	144	1	010970625	14,252	<b>15</b>	2	114	212	1	010971500	19,137
6,5	1	63	144	1	010970650	12,948	15,25	2	120	218	1	010971525	21,042
6,75	1	69	150	1	010970675	14,252	15,5	2	120	218	1	010971550	19,137
<b>7</b>	1	69	150	1	010970700	12,948	15,75	2	120	218	1	010971575	23,888
7,25	1	69	150	1	010970725	14,252	<b>16</b>	2	120	218	1	010971600	21,714
7,5	1	69	150	1	010970750	12,948	16,25	2	125	223	1	010971625	25,751
7,75	1	75	156	1	010970775	14,252	16,5	2	125	223	1	010971650	23,401
<b>8</b>	1	75	156	1	010970800	12,948	16,75	2	125	223	1	010971675	27,552
8,25	1	75	156	1	010970825	14,252	<b>17</b>	2	125	223	1	010971700	25,047
8,5	1	75	156	1	010970850	12,948	17,25	2	130	228	1	010971725	28,939
8,75	1	81	162	1	010970875	14,252	17,5	2	130	228	1	010971750	26,310
<b>9</b>	1	81	162	1	010970900	12,948	17,75	2	130	228	1	010971775	30,388
9,25	1	81	162	1	010970925	14,252	<b>18</b>	2	130	228	1	010971800	27,614
9,5	1	81	162	1	010970950	12,948	18,25	2	135	233	1	010971825	30,388
9,75	1	87	168	1	010970975	14,252	18,5	2	135	233	1	010971850	27,614
<b>10</b>	1	87	168	1	010971000	12,948	18,75	2	135	233	1	010971875	33,503
10,25	1	87	168	1	010971025	15,618	<b>19</b>	2	135	233	1	010971900	30,460
10,5	1	87	168	1	010971050	14,190	19,25	2	140	238	1	010971925	34,476
10,75	1	94	175	1	010971075	15,618	19,5	2	140	238	1	010971950	31,350
<b>11</b>	1	94	175	1	010971100	14,190	19,75	2	140	238	1	010971975	35,521
11,25	1	94	175	1	010971125	15,618	<b>20</b>	2	140	238	1	010972000	32,292
11,5	1	94	175	1	010971150	14,190	20,25	2	145	243	1	010972025	35,521
11,75	1	94	175	1	010971175	16,891	20,5	2	145	243	1	010972050	32,292
<b>12</b>	1	101	182	1	010971200	15,359	20,75	2	145	243	1	010972075	38,036
12,25	1	101	182	1	010971225	16,891	<b>21</b>	2	145	243	1	010972100	34,590
12,5	1	101	182	1	010971250	15,359	21,25	2	150	248	1	010972125	38,036
12,75	1	101	182	1	010971275	18,620	21,5	2	150	248	1	010972150	34,590
<b>13</b>	1	101	182	1	010971300	16,922	21,75	2	150	248	1	010972175	39,040
13,25	1	108	189	1	010971325	18,612	<b>22</b>	2	150	248	1	010972200	35,490
13,5	1	108	189	1	010971350	16,922	22,25	2	155	248	1	010972225	39,040
13,75	1	108	189	1	010971375	21,042	22,5	2	155	253	1	010972250	35,490
<b>14</b>	1	108	189	1	010971400	19,137	22,75	2	155	253	1	010972275	43,046
14,25	2	114	212	1	010971425	21,042	<b>23</b>	2	155	253	1	010972300	39,123



Velocità di taglio consigliata / Recommended cutting speed  
Acciaio / Steel - 10 m/min

Taglio dei materiali con  $R \leq 800 \text{ N/mm}^2$  quali acciai legati, ghise, tutti i metalli in genere, la grafite. Precisione di foratura e costanza di rendimenti elevati.  
High precision and high performances in cutting alloy steel up to  $R \leq 800 \text{ N/mm}^2$  /> Puor percer métaux et acier avec  $R \leq 800 \text{ N/mm}^2$  / Para taladrar hierro e acero  $R \leq 800 \text{ N/mm}^2$  / Einsatz in Stahl und Stahlguss, legiert und unlegiert bis  $R \leq 800 \text{ N/mm}^2$  Zug-Festigkeit, Ne-Metalle, Kunststoffe

d	M.K.	$l_2$	$l_1$		cod.	€ cad/each
23,25	3	155	276	1	010972325	52,951
23,5	3	155	276	1	010972350	48,138
23,75	3	160	281	1	010972375	52,951
<b>24</b>	3	160	281	1	010972400	48,138
24,25	3	160	281	1	010972425	52,951
24,5	3	160	281	1	010972450	48,138
24,75	3	160	281	1	010972475	54,058
<b>25</b>	3	160	281	1	010972500	49,142
25,25	3	165	286	1	010972525	54,058
25,5	3	165	286	1	010972550	49,142
25,75	3	165	286	1	010972575	67,109
<b>26</b>	3	165	286	1	010972600	61,013
26,25	3	165	286	1	010972625	67,109
26,5	3	165	286	1	010972650	61,013
26,75	3	170	291	1	010972675	69,800
<b>27</b>	3	170	291	1	010972700	63,456
27,25	3	170	291	1	010972725	69,800
27,5	3	170	291	1	010972750	63,456
27,75	3	170	291	1	010972775	72,585
<b>28</b>	3	170	291	1	010972800	65,992
28,25	3	175	296	1	010972825	72,585
28,5	3	175	296	1	010972850	65,992
28,75	3	175	296	1	010972875	83,483
<b>29</b>	3	175	296	1	010972900	75,897
29,25	3	175	296	1	010972925	83,483
29,5	3	175	296	1	010972950	75,897
29,75	3	175	296	1	010972975	85,998
<b>30</b>	3	175	296	1	010973000	78,184
30,25	3	180	301	1	010973025	85,998
30,5	3	180	301	1	010973050	78,184
30,75	3	180	301	1	010973075	96,317
<b>31</b>	3	180	301	1	010973100	87,561
31,25	3	180	301	1	010973125	101,316
31,5	3	180	301	1	010973150	92,094
31,75	3	185	306	1	010973175	103,334
<b>32</b>	4	185	334	1	010973200	93,947
32,25	4	185	334	1	010973225	103,336
32,5	4	185	334	1	010973250	93,945
32,75	4	185	334	1	010973275	103,336
<b>33</b>	4	185	334	1	010973300	93,945
33,25	4	185	334	1	010973325	119,781
33,5	4	185	334	1	010973350	108,779
33,75	4	185	334	1	010973375	123,144
<b>34</b>	4	190	339	1	010973400	110,952
34,25	4	190	339	1	010973425	130,979
34,5	4	190	339	1	010973450	119,781
34,75	4	190	339	1	010973475	137,696
<b>35</b>	4	190	339	1	010973500	125,380
35,25	4	190	339	1	010973525	137,696
35,5	4	190	339	1	010973550	125,380
35,75	4	190	339	1	010973575	158,966
<b>36</b>	4	195	344	1	010973600	144,414
36,25	4	195	344	1	010973625	158,966
36,5	4	195	344	1	010973650	144,414
36,75	4	195	344	1	010973675	158,966
<b>37</b>	4	195	344	1	010973700	144,414
37,25	4	195	344	1	010973725	158,966
37,5	4	195	344	1	010973750	144,414
37,75	4	195	344	1	010973775	183,588
<b>38</b>	4	200	349	1	010973800	166,801
38,25	4	200	349	1	010973825	183,588
38,5	4	200	349	1	010973850	166,801
38,75	4	200	349	1	010973875	183,588
<b>39</b>	4	200	349	1	010973900	166,801
39,25	4	200	349	1	010973925	183,588
39,5	4	200	349	1	010973950	166,801
39,75	4	200	349	1	010973975	183,588
<b>40</b>	4	200	349	1	010974000	166,801
40,5	4	205	354	1	010974050	200,386
<b>41</b>	4	205	354	1	010974100	200,386

d	M.K.	$l_2$	$l_1$		cod.	€ cad/each
41,5	4	205	354	1	010974150	205,975
<b>42</b>	4	205	354	1	010974200	205,975
42,5	4	205	354	1	010974250	205,975
<b>43</b>	4	210	359	1	010974300	205,975
43,5	4	210	359	1	010974350	205,975
<b>44</b>	4	210	359	1	010974400	214,938
44,5	4	210	359	1	010974450	214,938
<b>45</b>	4	210	359	1	010974500	225,009
45,5	4	215	364	1	010974550	225,009
<b>46</b>	4	215	364	1	010974600	225,009
46,5	4	215	364	1	010974650	225,009
<b>47</b>	4	215	364	1	010974700	248,524
47,5	4	215	364	1	010974750	248,524
<b>48</b>	4	220	369	1	010974800	248,524
48,5	4	220	369	1	010974850	273,147
<b>49</b>	4	220	369	1	010974900	273,147
49,5	4	220	369	1	010974950	282,100
<b>50</b>	4	220	369	1	010975000	282,100
50,5	4	225	374	1	010975050	336,955
51	5	225	412	1	010975100	336,955
52	5	225	412	1	010975200	336,955
53	5	225	412	1	010975300	336,955
54	5	230	417	1	010975400	410,843
<b>55</b>	5	230	417	1	010975500	410,843
56	5	230	417	1	010975600	472,415
57	5	235	422	1	010975700	472,415
58	5	235	422	1	010975800	472,415
59	5	235	422	1	010975900	472,415
<b>60</b>	5	235	422	1	010976000	472,415
61	5	240	427	1	010976100	623,536
62	5	240	427	1	010976200	623,536
63	5	240	427	1	010976300	623,536
64	5	245	432	1	010976400	623,536
<b>65</b>	5	245	432	1	010976500	623,536
66	5	245	432	1	010976600	792,572
67	5	245	432	1	010976700	792,572
68	5	250	437	1	010976800	792,572
69	5	250	437	1	010976900	792,572
<b>70</b>	5	250	437	1	010977000	1069,083
71	5	250	437	1	010977100	1108,257
72	5	255	442	1	010977200	1165,358
73	5	255	442	1	010977300	1209,015
74	5	255	442	1	010977400	1279,539
<b>75</b>	5	255	442	1	010977500	1303,044
76	5	260	447	1	010977600	1417,236
77	6	260	514	1	010977700	1462,010
78	6	260	514	1	010977800	1507,912
79	6	260	514	1	010977900	1576,191
<b>80</b>	6	260	514	1	010978000	1622,093
81	6	265	519	1	010978100	1713,888
82	6	265	519	1	010978200	1736,275
83	6	265	519	1	010978300	1804,564
84	6	265	519	1	010978400	1804,564
<b>85</b>	6	265	519	1	010978500	1828,069
86	6	270	524	1	010978600	1873,971
87	6	270	524	1	010978700	1896,358
88	6	270	524	1	010978800	1942,260
89	6	270	524	1	010978900	1988,152
<b>90</b>	6	270	524	1	010979000	1988,152
91	6	275	529	1	010979100	2147,118
92	6	275	529	1	010979200	2238,912
93	6	275	529	1	010979300	2261,299
94	6	275	529	1	010979400	2261,299
<b>95</b>	6	275	529	1	010979500	2307,201
96	6	280	534	1	010979600	2373,245
97	6	280	534	1	010979700	2421,383
98	6	280	534	1	010979800	2467,285
99	6	280	534	1	010979900	2646,392
<b>100</b>	6	280	534	1	0109710000	3764,730



## 01028

### Punte elicoidali codolo conico Morse, serie lunga, esecuzione fresata

Morse taper shank twist drills, long serie / Forets à queue conique Morse, série longue

Brocas helicoidales con mango conico, serie larga / Spiralbohrer mit Morsekegel, lange Ausführung

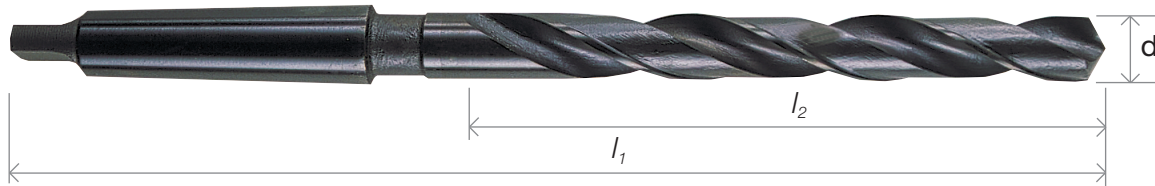
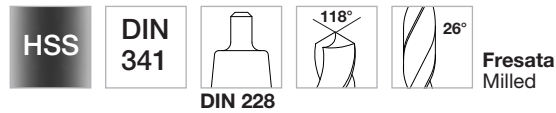

d	M.K.	$l_2$	$l_1$		cod.	€ cad/each	d	M.K.	$l_2$	$l_1$		cod.	€ cad/each
8	1	100	181	1	010280800	27,593	24,5	3	206	327	1	010282450	125,001
8,5	1	100	181	1	010280850	28,452	25	3	206	327	1	010282500	133,536
9	1	107	188	1	010280900	31,599	25,5	3	214	335	1	010282550	139,332
9,5	1	107	188	1	010280950	31,599	26	3	214	335	1	010282600	139,332
10	1	116	197	1	010281000	32,044	26,5	3	214	335	1	010282650	154,267
10,25	1	116	197	1	010281025	33,679	27	3	222	343	1	010282700	154,267
10,5	1	116	197	1	010281050	33,679	27,5	3	222	343	1	010282750	158,624
11	1	125	206	1	010281100	35,076	28	3	222	343	1	010282800	158,624
11,5	1	125	206	1	010281150	37,736	28,5	3	230	351	1	010282850	171,727
12	1	134	215	1	010281200	39,485	29	3	230	351	1	010282900	171,727
12,25	1	134	215	1	010281225	41,214	29,5	3	230	351	1	010282950	180,452
12,5	1	134	215	1	010281250	41,214	30	3	230	351	1	010283000	180,452
13	1	134	215	1	010281300	41,214	31	3	239	360	1	010283100	203,740
13,25	1	142	223	1	010281325	44,691	32	4	248	397	1	010283200	225,568
13,5	1	142	223	1	010281350	44,691	33	4	248	397	1	010283300	253,223
14	1	142	223	1	010281400	47,444	34	4	257	406	1	010283400	270,684
14,5	2	147	245	1	010281450	50,053	35	4	257	406	1	010283500	276,511
15	2	147	245	1	010281500	55,155	35,5	4	267	416	1	010283550	304,611
15,5	2	153	251	1	010281550	57,349	36	4	267	416	1	010283600	305,615
16	2	153	251	1	010281600	57,349	36,5	4	267	416	1	010283650	315,892
16,5	2	159	257	1	010281650	60,735	37	4	267	416	1	010283700	315,799
17	2	159	257	1	010281700	60,735	37,5	4	267	416	1	010283750	332,815
17,5	2	165	263	1	010281750	64,108	38	4	277	426	1	010283800	331,811
18	2	165	263	1	010281800	68,621	39	4	277	426	1	010283900	360,915
18,5	2	171	269	1	010281850	71,415	40	4	277	426	1	010284000	372,559
19	2	171	269	1	010281900	71,415	41	4	287	436	1	010284100	406,031
19,5	2	177	275	1	010281950	74,551	42	4	287	436	1	010284200	427,859
20	2	177	275	1	010282000	74,551	43	4	298	447	1	010284300	472,974
20,5	2	184	282	1	010282050	86,630	44	4	298	447	1	010284400	483,159
21	2	184	282	1	010282100	86,630	45	4	298	447	1	010284500	518,090
21,5	2	191	289	1	010282150	94,527	46	4	310	459	1	010284600	529,723
22	2	191	289	1	010282200	94,527	47	4	310	459	1	010284700	551,552
22,5	2	198	296	1	010282250	100,095	48	4	321	470	1	010284800	598,127
23	2	198	296	1	010282300	107,992	49	4	321	470	1	010284900	612,679
23,5	3	198	319	1	010282350	111,480	50	4	321	470	1	010285000	619,955
24	3	206	327	1	010282400	121,343							

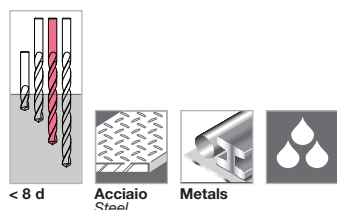

Velocità di taglio consigliata / Recommended cutting speed  
Acciaio / Steel - 10 m/min

Taglio dei materiali con  $R \leq 800 \text{ N/mm}^2$  quali acciai legati, ghise, tutti i metalli in genere, la grafite. Precisione di foratura e costanza di rendimenti elevati.  
High precision and high performances in cutting alloy steel up to  $R \leq 800 \text{ N/mm}^2$  /> Puor percer métaux et acier avec  $R \leq 800 \text{ N/mm}^2$  / Para taladrar hierro e acero  $R \leq 800 \text{ N/mm}^2$  / Einsatz in Stahl und Stahlguss, legiert und unlegiert bis  $R \leq 800 \text{ N/mm}^2$  Zug-Festigkeit, Ne-Metalle, Kunststoffe

# 01069

## Punte elicoidali codolo conico Morse con fori di lubrorefrigerazione

Morse taper shank twist drills with internal coolant / Forets a queue conique Morse avec trous réfrigérants

Brocas helicoidales con mango conico / Spiralbohrer mit Morsekegel mit Schmierloch

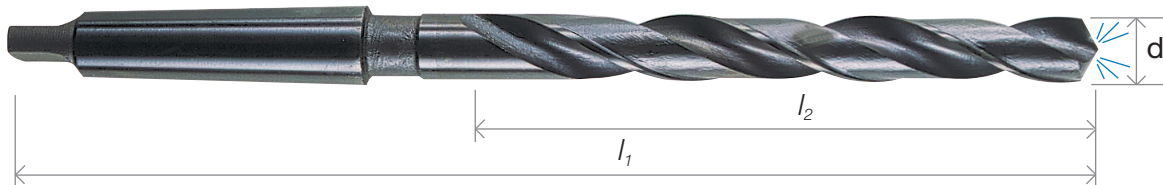
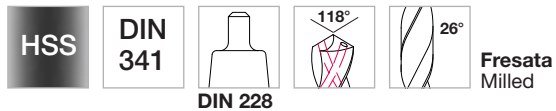

d	M.K.	$l_2$	$l_1$		cod.	€ cad/each
10	2	116	233	1	010691000	306,215
11	2	125	242	1	010691100	345,587
12	2	134	251	1	010691200	327,888
13	2	134	251	1	010691300	332,173
14	2	142	259	1	010691400	340,432
15	2	147	264	1	010691500	409,177
16	2	153	270	1	010691600	403,588
17	2	159	276	1	010691700	440,103
18	2	165	282	1	010691800	450,846
19	3	171	307	1	010691900	641,990
20	3	177	313	1	010692000	652,174
21	3	184	320	1	010692100	669,003
22	3	191	327	1	010692200	659,937
23	3	198	334	1	010692300	778,361
24	3	206	342	1	010692400	773,704
25	3	206	342	1	010692500	833,072
26	3	214	350	1	010692600	833,072
27	4	222	385	1	010692700	1008,194
28	4	222	385	1	010692800	1002,418
29	4	230	393	1	010692900	1095,568
30	4	230	393	1	010693000	1061,848
32	4	248	421	1	010693200	1180,583

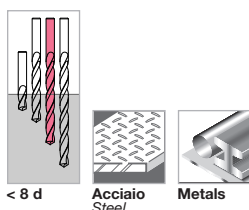

**Velocità di taglio consigliata / Recommended cutting speed**  
**Acciaio / Steel - 10 m/min**

Taglio dei materiali con  $R \leq 800 \text{ N/mm}^2$  quali acciai legati, ghise, tutti i metalli in genere, la grafite, taglio di lamierini in pacchi. Precisione di foratura e costanza di rendimenti elevati. High precision and high performances in cutting alloy steel up to  $R \leq 800 \text{ N/mm}^2$  / Puor percer métaux et acier avec  $R \leq 800 \text{ N/mm}^2$  / Para taladrar hierro e acero  $R \leq 800 \text{ N/mm}^2$  / Einsatz in Stahl und Stahlguss, legiert und unlegiert bis  $R \leq 800 \text{ N/mm}^2$  Zug-Festigkeit, Ne-Metalle, Kunststoffe

## 01088

### Punte elicoidali codolo conico Morse, serie extra lunga, esecuzione fresata

Morse taper shank twist drills, extra long serie / Forets à queue conique Morse, série extra longue

Brocas helicoidales con mango conico, serie extra larga / Spiralbohrer mit Morsekegel, extra lange Ausführung

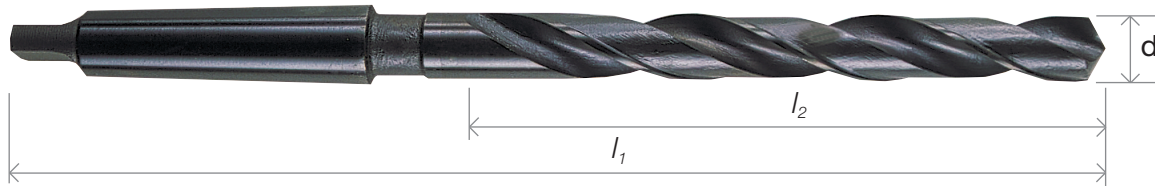
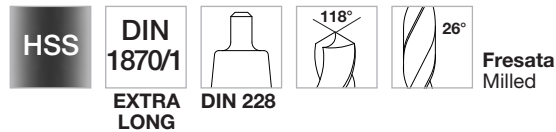

d	M.K.	$l_2$	$l_1$		cod.	€ cad/each	d	M.K.	$l_2$	$l_1$		cod.	€ cad/each
8	1	165	265	1	010880800	90,418	24,5	3	290	440	1	010882450	476,928
8,5	1	165	265	1	010880850	101,347	25	3	290	440	1	010882500	433,210
9	1	175	275	1	010880900	101,347	25,5	3	290	440	1	010882550	516,672
9,5	1	175	275	1	010880950	109,296	26	3	290	440	1	010882600	465,005
10	1	185	285	1	010881000	109,296	26,5	3	290	440	1	010882650	548,467
10,5	1	185	285	1	010881050	125,194	27	3	305	460	1	010882700	480,902
11	1	195	300	1	010881100	125,194	27,5	3	305	460	1	010882750	568,339
11,5	1	195	300	1	010881150	137,117	28	3	305	460	1	010882800	516,672
12	1	205	310	1	010881200	131,155	28,5	3	305	460	1	010882850	608,083
12,5	1	205	310	1	010881250	133,142	29	3	305	460	1	010882900	548,467
13	1	205	310	1	010881300	131,155	29,5	3	305	460	1	010882950	635,904
13,5	1	220	325	1	010881350	147,053	30	3	305	460	1	010883000	564,365
14	1	220	325	1	010881400	147,053	31	3	320	480	1	010883100	683,597
14,5	2	220	340	1	010881450	164,938	32	4	320	505	1	010883200	699,494
15	2	220	340	1	010881500	174,874	33	4	320	505	1	010883300	731,290
15,5	2	230	355	1	010881550	186,797	34	4	340	530	1	010883400	790,906
16	2	230	355	1	010881600	180,835	35	4	340	530	1	010883500	802,829
16,5	2	230	355	1	010881650	182,822	36	4	340	530	1	010883600	854,496
17	2	230	355	1	010881700	202,694	37	4	340	530	1	010883700	862,445
17,5	2	245	370	1	010881750	222,566	38	4	360	555	1	010883800	914,112
18	2	245	370	1	010881800	218,592	39	4	360	555	1	010883900	961,805
18,5	2	245	370	1	010881850	220,579	40	4	360	555	1	010884000	965,779
19	2	245	370	1	010881900	220,579	41	4	360	555	1	010884100	1033,344
19,5	2	260	385	1	010881950	246,413	42	4	360	555	1	010884200	1053,216
20	2	260	385	1	010882000	240,451	43	4	385	585	1	010884300	1152,576
20,5	2	260	385	1	010882050	319,939	44	4	385	585	1	010884400	1152,576
21	2	260	385	1	010882100	296,093	45	4	385	585	1	010884500	1212,192
21,5	2	270	405	1	010882150	347,760	46	4	385	585	1	010884600	1271,808
22	2	270	405	1	010882200	313,978	47	4	385	585	1	010884700	1331,424
22,5	2	270	405	1	010882250	379,555	48	4	405	605	1	010884800	1450,656
23	2	270	405	1	010882300	359,683	49	4	405	605	1	010884900	1510,272
23,5	3	270	425	1	010882350	449,107	50	4	405	605	1	010885000	1490,400
24	3	290	440	1	010882400	409,363							

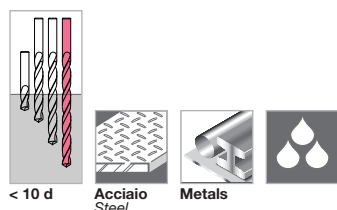

Velocità di taglio consigliata / Recommended cutting speed  
Acciaio / Steel - 10 m/min

Taglio dei materiali con  $R \leq 800 \text{ N/mm}^2$  quali acciai legati, ghise, tutti i metalli in genere, la grafite. Precisione di foratura e costanza di rendimenti elevati.  
High precision and high performances in cutting alloy steel up to  $R \leq 800 \text{ N/mm}^2$  /> Puor percer métaux et acier avec  $R \leq 800 \text{ N/mm}^2$  / Para taladrar hierro e acero  $R \leq 800 \text{ N/mm}^2$  / Einsatz in Stahl und Stahlguss, legiert und unlegiert bis  $R \leq 800 \text{ N/mm}^2$  Zug-Festigkeit, Ne-Metalle, Kunststoffe

# 01213

## Punte elicoidali codolo conico Morse con taglienti in metallo duro

Morse taper shank twist drills with carbide tips / Forets à queue conique Morse

Brocas helicoidales con mango conico / Spiralbohrer mit Morsekegel

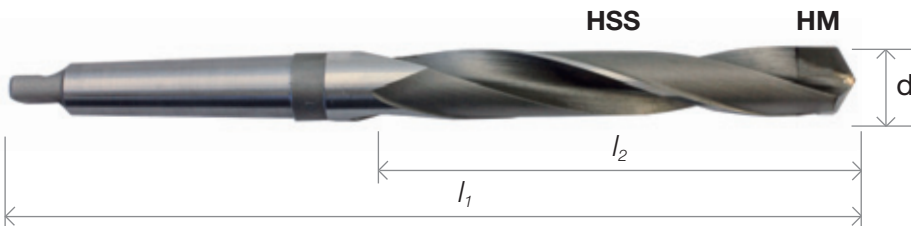
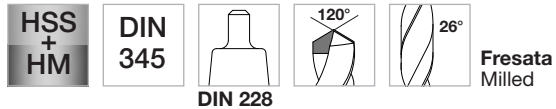

d	M.K.	$l_2$	$l_1$		cod.	€ cad/each
10	1	87	168	1	012131000	101,316
10,5	1	87	168	1	012131050	101,316
11	1	94	175	1	012131100	101,316
11,5	1	94	175	1	012131150	105,787
12	1	101	182	1	012131200	105,787
12,5	1	101	182	1	012131250	113,063
13	1	101	182	1	012131300	113,063
13,5	1	108	189	1	012131350	130,979
14	1	108	189	1	012131400	130,979
14,5	2	114	212	1	012131450	134,333
15	2	114	212	1	012131500	134,333
15,5	2	120	218	1	012131550	139,932
16	2	120	218	1	012131600	139,932
16,5	2	125	223	1	012131650	153,366
17	2	125	223	1	012131700	153,366
17,5	2	130	228	1	012131750	153,366
18	2	130	228	1	012131800	153,366
18,5	2	135	233	1	012131850	162,319
19	2	135	233	1	012131900	162,319
19,5	2	140	238	1	012131950	208,221
20	2	140	238	1	012132000	208,221
20,5	2	145	243	1	012132050	223,891
21	2	145	243	1	012132100	223,891
21,5	2	150	248	1	012132150	229,491
22	2	150	248	1	012132200	229,491
22,5	2	155	253	1	012132250	235,090

d	M.K.	$l_2$	$l_1$		cod.	€ cad/each
23	2	155	253	1	012132300	235,090
23,5	3	155	276	1	012132350	244,043
24	3	160	281	1	012132400	244,043
24,5	3	160	281	1	012132450	257,477
25	3	160	281	1	012132500	257,477
25,5	3	165	286	1	012132550	321,285
26	3	165	286	1	012132600	321,285
26,5	3	165	286	1	012132650	333,601
27	3	170	291	1	012132700	333,601
27,5	3	170	291	1	012132750	351,507
28	3	170	291	1	012132800	351,507
28,5	3	175	296	1	012132850	391,810
29	3	175	296	1	012132900	391,810
29,5	3	175	296	1	012132950	422,032
30	3	175	296	1	012133000	422,032
30,5	3	180	301	1	012133050	442,980
31	3	180	301	1	012133100	442,980
31,5	3	180	301	1	012133150	492,660
32	4	185	334	1	012133200	492,660
32,5	4	185	334	1	012133250	499,905
33	4	185	334	1	012133300	499,905
33,5	4	185	334	1	012133350	511,290
34	4	190	339	1	012133400	511,290
34,5	4	190	339	1	012133450	521,640
35	4	190	339	1	012133500	521,640

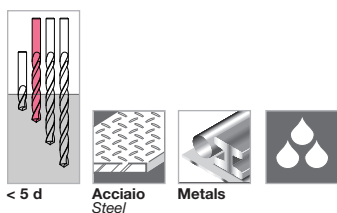

Taglio di acciai duri con  $R \leq 1100 \text{ N/mm}^2$ , acciai per molle, ghisa temperata, molibdeno puro, bronzo duro, materie plastiche termoindurenti con azione abrasiva, materie sintetiche con fibre vetrose,.... Cut of hard steels  $R \leq 1100 \text{ N/mm}^2$ , spring steel, hard cast iron, Mo, hard bronze, abrasive thermosetting plastics, glass fiber reinforced plastics,.... / Pour travaille aciers durs avec  $R \leq 1100 \text{ N/mm}^2$ , acier pour meule, de fer trempé, de molybdène pur, en bronze, matières plastiques therm durcissables avec action abrasive, en plastique avec des fibres de verre.. / Para trabajar aceros duro con  $R \leq 1100 \text{ N/mm}^2$ , aceros de resorte, de hierro fundido templado, molibdeno puro, bronce, plástico termoestable con una acción abrasiva, plásticos con fibras de vidrio

## 01066

Punte elicoidali cilindriche, esecuzione interamente rettificata, serie corta con angolo al vertice di 118°

Fully ground straight shank twist drills / Forets cylindriques rectifiés

Brocas helicoidales rectificadas / Geschliffene Spiralbohrer

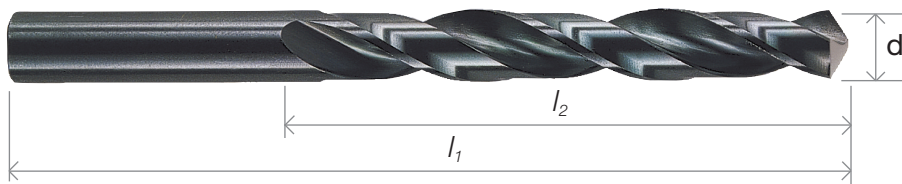
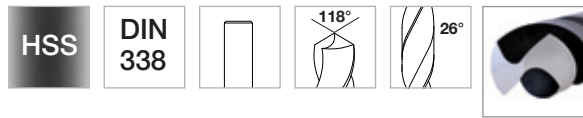

d	l <sub>2</sub>	l <sub>1</sub>		cod.	€ cad/each
1	12	34	10	010660100	0,652
1,25	16	38	10	010660125	0,652
1,5	18	40	10	010660150	0,652
1,75	22	46	10	010660175	0,652
2	24	49	10	010660200	0,652
2,25	27	53	10	010660225	0,652
2,5	30	57	10	010660250	0,652
2,75	33	61	10	010660275	0,652
2,8	33	61	10	010660280	0,652
3	33	61	10	010660300	0,652
3,2	36	65	10	010660320	0,766
3,25	36	65	10	010660325	0,766
3,3	36	65	10	010660330	0,766
3,4	39	70	10	010660340	0,766
3,5	39	70	10	010660350	0,766
3,7	39	70	10	010660370	0,828
3,75	39	70	10	010660375	0,828
3,8	43	75	10	010660380	0,828
4	43	75	10	010660400	0,828
4,1	43	75	10	010660410	1,056
4,2	43	75	10	010660420	1,056
4,25	43	75	10	010660425	1,056
4,5	47	80	10	010660450	1,056
4,75	47	80	10	010660475	1,325
4,8	52	86	10	010660480	1,325
5	52	86	10	010660500	1,325
5,2	52	86	10	010660520	1,749
5,25	52	86	10	010660525	1,749
5,5	57	93	10	010660550	1,749
5,75	57	93	10	010660575	2,018

d	l <sub>2</sub>	l <sub>1</sub>		cod.	€ cad/each
6	57	93	10	010660600	2,018
6,25	63	101	10	010660625	2,184
6,5	63	101	10	010660650	2,184
6,75	69	109	10	010660675	2,639
7	69	109	10	010660700	2,639
7,25	69	109	5	010660725	3,095
7,5	69	109	5	010660750	3,095
7,75	75	117	5	010660775	3,902
8	75	117	5	010660800	3,902
8,25	75	117	5	010660825	4,233
8,5	75	117	5	010660850	4,233
8,75	81	125	5	010660875	4,927
9	81	125	5	010660900	4,927
9,25	81	125	5	010660925	5,361
9,5	81	125	5	010660950	5,361
9,75	87	133	5	010660975	6,034
10	87	133	5	010661000	6,034
10,25	87	133	5	010661025	6,728
10,5	87	133	5	010661050	6,728
10,75	94	142	5	010661075	7,556
11	94	142	5	010661100	7,556
11,25	94	142	5	010661125	8,228
11,5	94	142	5	010661150	8,228
11,75	94	142	5	010661175	9,491
12	101	151	5	010661200	9,491
12,25	101	151	5	010661225	10,381
12,5	101	151	5	010661250	10,381
12,75	101	151	5	010661275	11,250
13	101	151	5	010661300	11,250

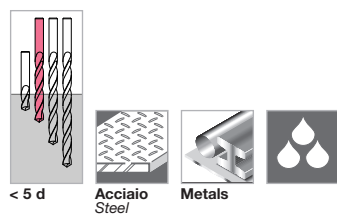

Velocità di taglio consigliata  
Recommended cutting speed  
Acciaio / Steel - 10 m/min



19 pcs - Ø 1÷10 x 0,5 mm  
01068311 € 49,318

25 pcs - Ø 1÷13 x 0,5 mm  
01068312 € 98,780



Metal  
331x228x48

150 pcs - Ø 1÷10 x 0,5 mm  
Ø 1 ÷ 5 mm - 10 pcs  
Ø 3 mm - 20 pcs  
Ø 5,5 ÷ 10 mm - 5 pcs

01068460 € 254,413

# 01022

Punte elicoidali cilindriche, esecuzione interamente rettificata, serie extra corta con angolo al vertice di 118° Fully ground straight shank twist drills, stub serie / Forets cylindriques rectifiés, série extra courte

Braocas helicoidales rectificadas, serie extra corta / Geschliffene Spiralbohrer, extra kurz

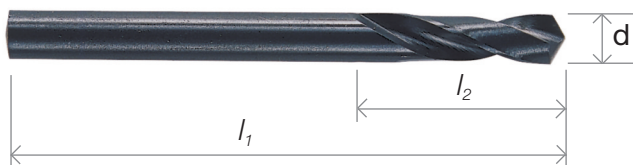
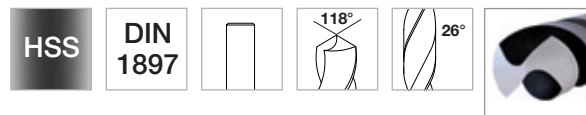

d	$l_2$	$l_1$		cod.	€ cad/each
2,5	14	43	10	010220250	0,859
<b>3</b>	16	46	10	010220300	1,066
3,2	18	49	10	010220320	1,170
3,25	18	49	10	010220325	1,170
<b>3,5</b>	20	52	10	010220350	1,170
3,7	20	52	10	010220370	1,294
3,75	20	52	10	010220375	1,294
<b>4</b>	22	55	10	010220400	1,294
4,2	22	55	10	010220420	1,615
4,25	22	55	10	010220425	1,615
4,5	24	58	10	010220450	1,470
<b>5</b>	26	62	10	010220500	1,532
5,5	28	66	10	010220550	2,029
<b>6</b>	28	66	10	010220600	2,267

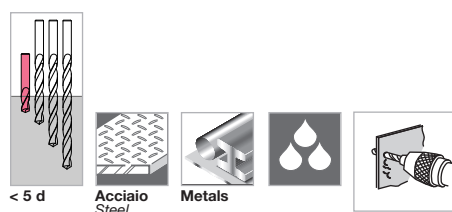

**Velocità di taglio consigliata / Recommended cutting speed**  
**Acciaio / Steel - 10 m/min**

Taglio dei materiali con  $R_s \leq 800$  N/mm<sup>2</sup> quali acciai legati, ghise, tutti i metalli in genere, la grafite. Precisione di foratura e costanza di rendimenti elevati. High precision and high performances in cutting alloy steel up to  $R_s \leq 800$  N/mm<sup>2</sup> / Pour percer métaux et acier avec  $R_s \leq 800$  N/mm<sup>2</sup> / Para taladrar hierro y acero  $R_s \leq 800$  N/mm<sup>2</sup> / Einsatz in Stahl und Stahlguss, legiert und unlegiert bis  $R_s \leq 800$  N/mm<sup>2</sup> Zug-Festigkeit, Ne-Metalle, Kunststoffe.

## 01201

Punte elicoidali cilindriche, esecuzione interamente rettificata, "Dual Performer®"

Fully ground straight shank twist drills "Dual Performer®" / Forets cylindriques rectifiés "Dual Performer®"

Brocas helicoidales rectificadas "Dual Performer®" / Geschliffene Spiralbohrer "Dual Performer®"

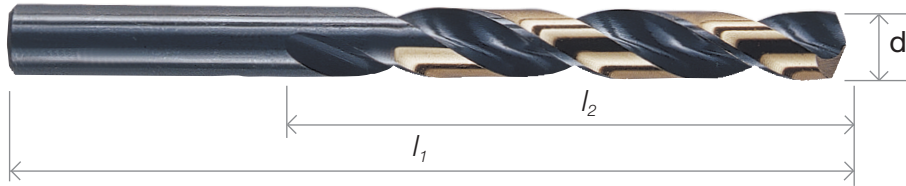
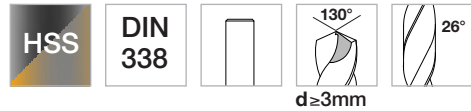

d	l <sub>2</sub>	l <sub>1</sub>		cod.	€ cad/each	d	l <sub>2</sub>	l <sub>1</sub>		cod.	€ cad/each
<b>h8</b>						<b>h8</b>					
0,3	3	19	10	012010030	2,349	2	24	49	10	012010200	0,973
0,35	4	19	10	012010035	2,349	2,1	24	49	10	012010210	1,170
0,4	5	20	10	012010040	2,349	2,2	27	53	10	012010220	1,170
0,45	5	20	10	012010045	2,349	<b>2,25</b>	27	53	10	012010225	1,170
0,5	6	22	10	012010050	2,349	2,3	27	53	10	012010230	1,170
0,55	7	24	10	012010055	2,349	2,4	30	57	10	012010240	1,170
0,6	7	24	10	012010060	2,349	<b>2,5</b>	30	57	10	012010250	1,066
0,65	8	26	10	012010065	2,349	2,6	30	57	10	012010260	1,377
0,7	9	28	10	012010070	2,349	2,7	33	61	10	012010270	1,377
0,75	9	28	10	012010075	2,349	<b>2,75</b>	33	61	10	012010275	1,377
0,8	10	30	10	012010080	2,349	2,8	33	61	10	012010280	1,377
0,85	10	30	10	012010085	2,349	2,9	33	61	10	012010290	1,377
0,9	11	32	10	012010090	2,349	<b>3</b>	33	61	10	012010300	1,252
0,95	11	32	10	012010095	2,349	3,1	36	65	10	012010310	1,553
<b>1</b>	12	34	10	012010100	1,273	3,2	36	65	10	012010320	1,553
1,1	14	36	10	012010110	1,346	<b>3,25</b>	36	65	10	012010325	1,553
1,2	16	38	10	012010120	1,346	3,3	36	65	10	012010330	1,553
<b>1,25</b>	16	38	10	012010125	1,346	3,4	39	70	10	012010340	1,553
1,3	16	38	10	012010130	1,346	<b>3,5</b>	39	70	10	012010350	1,409
1,4	18	40	10	012010140	1,346	3,6	39	70	10	012010360	1,616
<b>1,5</b>	18	40	10	012010150	1,180	3,7	39	70	10	012010370	1,616
1,6	20	43	10	012010160	1,097	<b>3,75</b>	39	70	10	012010375	1,616
1,7	20	43	10	012010170	1,097	3,8	43	75	10	012010380	1,616
<b>1,75</b>	22	46	10	012010175	1,097	3,9	43	75	10	012010390	1,616
1,8	22	46	10	012010180	1,097	<b>4</b>	43	75	10	012010400	1,480
1,9	22	46	10	012010190	1,097	4,1	43	75	10	012010410	1,894

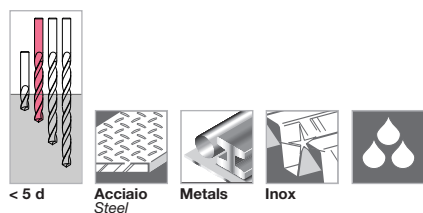

**Velocità di taglio consigliata / Recommended cutting speed**  
**Acciaio / Steel - 10 m/min**  
**Inox - 5 m/min**

< 5 d

Acciaio  
Steel

Metals

Inox





Abs

Taglio dei materiali con R ≤ 850 N/mm<sup>2</sup> quali acciai legati, ghise, tutti i metalli in genere, la grafite. Precisione di foratura e costanza di rendimenti elevati. High precision and high performances in cutting alloy steel up to R ≤ 850 N/mm<sup>2</sup> / Puor percer métaux et acier avec R ≤ 850 N/mm<sup>2</sup> / Para taladrar hierro e acero R ≤ 850 N/mm<sup>2</sup> / Einsatz in Stahl und Stahlguss, legiert und unlegiert bis R ≤ 850 N/mm<sup>2</sup> Zug-Festigkeit, Ne-Metalle, Kunststoffe.

19 pcs - Ø 1÷10 x 0,5 mm  
**01205301 € 53,737**

25 pcs - Ø 1÷13 x 0,5 mm  
**01205302 € 106,346**

d h8	$l_2$	$l_1$		cod.	€ cad/each
4,2	43	75	10	012010420	1,894
<b>4,25</b>	43	75	10	012010425	1,894
4,3	47	80	10	012010430	1,894
4,4	47	80	10	012010440	1,894
<b>4,5</b>	47	80	10	012010450	1,801
4,6	47	80	10	012010460	2,008
4,7	47	80	10	012010470	2,008
<b>4,75</b>	47	80	10	012010475	2,008
4,8	52	86	10	012010480	2,008
4,9	52	86	10	012010490	2,008
<b>5</b>	52	86	10	012010500	1,884
5,1	52	86	10	012010510	2,567
5,2	52	86	10	012010520	2,567
<b>5,25</b>	52	86	10	012010525	2,567
5,3	52	86	10	012010530	2,567
5,4	57	93	101	012010540	2,567
<b>5,5</b>	57	93	0	012010550	2,463
5,6	57	93	10	012010560	2,846
5,7	57	93	10	012010570	2,846
<b>5,75</b>	57	93	10	012010575	2,846
5,8	57	93	10	012010580	2,846
5,9	57	93	10	012010590	2,846
<b>6</b>	57	93	10	012010600	2,691
6,1	63	101	10	012010610	3,550
6,2	63	101	10	012010620	3,550
<b>6,25</b>	63	101	10	012010625	3,550
6,3	63	101	10	012010630	3,550
6,4	63	101	10	012010640	3,550
<b>6,5</b>	63	101	10	012010650	3,271
6,6	63	101	10	012010660	4,130
6,7	63	101	10	012010670	4,130
<b>6,75</b>	69	109	10	012010675	4,130
6,8	69	109	101	012010680	4,130
6,9	69	109	0	012010690	4,130
<b>7</b>	69	109	10	012010700	3,830
7,1	69	109	5	012010710	4,533
7,2	69	109	5	012010720	4,533
<b>7,25</b>	69	109	5	012010725	4,533
7,3	69	109	5	012010730	4,533
7,4	69	109	5	012010740	4,533
<b>7,5</b>	69	109	5	012010750	4,057
7,6	75	117	5	012010760	5,103
7,7	75	117	5	012010770	5,103
<b>7,75</b>	75	117	5	012010775	5,103
7,8	75	117	5	012010780	5,103
7,9	75	117	5	012010790	5,103
<b>8</b>	75	117	5	012010800	4,813
8,1	75	117	5	012010810	6,562
8,2	75	117	5	012010820	6,562
<b>8,25</b>	75	117	5	012010825	6,562
8,3	75	117	5	012010830	6,562
8,4	75	117	5	012010840	6,562

d h8	$l_2$	$l_1$		cod.	€ cad/each
<b>8,5</b>	75	117	5	012010850	6,251
8,6	81	125	5	012010860	6,717
8,7	81	125	5	012010870	6,717
<b>8,75</b>	81	125	5	012010875	6,717
8,8	81	125	5	012010880	6,717
8,9	81	125	5	012010890	6,717
<b>9</b>	81	125	5	012010900	6,407
9,1	81	125	5	012010910	7,514
9,2	81	125	5	012010920	7,514
<b>9,25</b>	81	125	5	012010925	7,514
9,3	81	125	5	012010930	7,514
9,4	81	125	5	012010940	7,514
<b>9,5</b>	81	125	5	012010950	7,152
9,6	87	133	5	012010960	7,721
9,7	87	133	5	012010970	7,721
<b>9,75</b>	87	133	5	012010975	7,721
9,8	87	133	5	012010980	7,721
9,9	87	133	5	012010990	7,721
<b>10</b>	87	133	5	012011000	7,359
10,25	87	133	5	012011025	9,936
10,5	87	133	5	012011050	8,694
10,75	94	142	5	012011075	11,954
<b>11</b>	94	142	5	012011100	10,422
11,25	94	142	5	012011125	12,710
11,5	94	142	5	012011150	11,116
11,75	94	142	5	012011175	13,828
<b>12</b>	101	151	5	012011200	11,985
12,25	101	151	5	012011225	15,059
12,5	101	151	5	012011250	13,103
12,75	101	151	5	012011275	17,057
<b>13</b>	101	151	5	012011300	13,828
13,25	108	160	3	012011325	20,938
13,5	108	160	3	012011350	19,013
13,75	108	160	3	012011375	21,569
<b>14</b>	108	160	3	012011400	19,613
14,25	114	169	3	012011425	24,633
14,5	114	169	3	012011450	22,377
14,75	114	169	3	012011475	28,918
<b>15</b>	114	169	3	012011500	26,289
15,25	120	178	3	012011525	31,650
15,5	120	178	3	012011550	28,763
15,75	120	178	3	012011575	32,789
<b>16</b>	120	178	3	012011600	29,798
16,5	125	184	1	012011650	30,833
<b>17</b>	125	184	1	012011700	32,344
17,5	130	191	1	012011750	33,896
<b>18</b>	130	191	1	012011800	36,028
18,5	135	198	1	012011850	39,216
<b>19</b>	135	198	1	012011900	40,500
19,5	140	205	1	012011950	42,425
<b>20</b>	140	205	1	012012000	44,453



## 01203

### Punte elicoidali cilindriche rettificate con codolo ridotto "Dual Performer<sup>®</sup>"

Fully ground straight shank twist drills "Dual Performer<sup>®</sup>" / Forets cylindriques rectifiés "Dual Performer<sup>®</sup>"

Brocas helicoidales rectificadas "Dual Performer<sup>®</sup>" / Geschliffene Spiralbohrer "Dual Performer<sup>®</sup>"

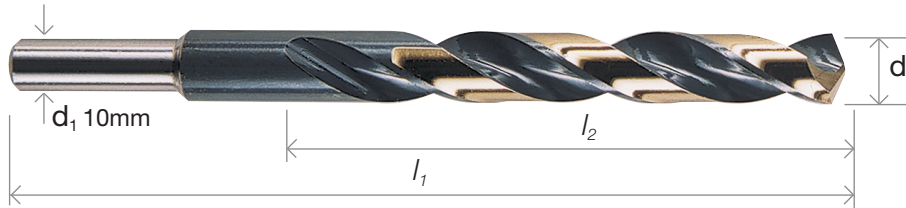
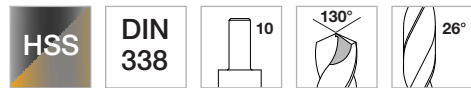

d	l <sub>2</sub>	l <sub>1</sub>	d <sub>1</sub>		cod.	€ cad/each
h8						
10,25	87	133	10	5	012031025	11,934
<b>10,5</b>	87	133	10	5	012031050	10,681
10,75	94	142	10	5	012031075	13,944
<b>11</b>	94	142	10	5	012031100	12,399
11,25	94	142	10	5	012031125	14,697
<b>11,5</b>	94	142	10	5	012031150	13,113
11,75	94	142	10	5	012031175	15,804
<b>12</b>	101	151	10	5	012031200	13,983
12,25	101	151	10	5	012031225	17,036
<b>12,5</b>	101	151	10	5	012031250	15,070
12,75	101	151	10	5	012031275	19,054
<b>13</b>	101	151	10	5	012031300	15,804
13,25	108	160	10	3	012031325	24,064
<b>13,5</b>	108	160	10	3	012031350	21,880
13,75	108	160	10	3	012031375	24,819
<b>14</b>	108	160	10	3	012031400	22,553

d	l <sub>2</sub>	l <sub>1</sub>	d <sub>1</sub>		cod.	€ cad/each
h8						
14,25	114	169	10	3	012031425	28,307
<b>14,5</b>	114	169	10	3	012031450	25,740
14,75	114	169	10	3	012031475	33,255
<b>15</b>	114	169	10	3	012031500	30,232
15,25	120	178	10	3	012031525	36,391
<b>15,5</b>	120	178	10	3	012031550	33,079
15,75	120	178	10	3	012031575	37,705
<b>16</b>	120	178	10	3	012031600	34,269
16,5	125	184	10	1	012031650	35,449
<b>17</b>	125	184	10	1	012031700	37,188
17,5	130	191	10	1	012031750	38,988
<b>18</b>	130	191	10	1	012031800	41,431
18,5	135	198	10	1	012031850	45,095
<b>19</b>	135	198	10	1	012031900	46,575
19,5	140	205	10	1	012031950	48,800
<b>20</b>	140	205	10	1	012032000	51,129

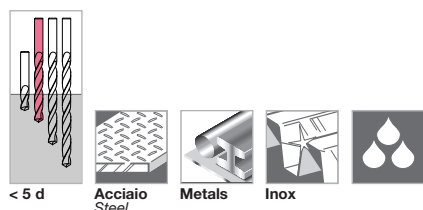

**Velocità di taglio consigliata / Recommended cutting speed**

**Acciaio / Steel - 10 m/min**

**Inox - 5 m/min**

Taglio dei materiali con R ≤ 850 N/mm<sup>2</sup> quali acciai legati, ghise, tutti i metalli in genere, la grafite. Precisione di foratura e costanza di rendimenti elevati.  
High precision and high performances in cutting alloy steel up to R ≤ 850 N/mm<sup>2</sup> / Pour percer métaux et acier avec R ≤ 850 N/mm<sup>2</sup> / Para taladrar hierro e acero R ≤ 850 N/mm<sup>2</sup> / Einsatz in Stahl und Stahlguss, legiert und unlegiert bis R ≤ 850 N/mm<sup>2</sup> Zug-Festigkeit, Ne-Metalle, Kunststoffe

# 01209

## Punte elicoidali cilindriche rettificate con codolo ridotto "Dual Performer®"

Fully ground straight shank twist drills "Dual Performer®" / Forets cylindriques rectifiés "Dual Performer®"

Brocas helicoidales rectificadas "Dual Performer®" / Geschliffene Spiralbohrer "Dual Performer®"

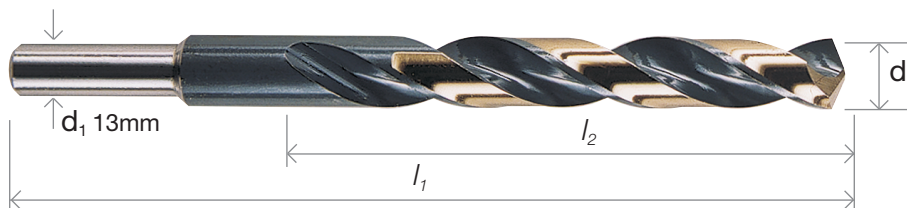
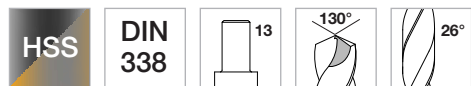

d	$l_2$	$l_1$	$d_1$		cod.	€ cad/each	d	$l_2$	$l_1$	$d_1$		cod.	€ cad/each
h8							h8						
13,25	108	160	13	3	012091325	24,064	15,75	120	178	13	3	012091575	37,705
<b>13,5</b>	108	160	13	3	012091350	21,880	<b>16</b>	120	178	13	3	012091600	34,269
13,75	108	160	13	3	012091375	24,819	16,5	125	184	13	1	012091650	35,449
<b>14</b>	108	160	13	3	012091400	22,553	<b>17</b>	125	184	13	1	012091700	37,188
14,25	114	169	13	3	012091425	28,307	17,5	130	191	13	1	012091750	38,988
<b>14,5</b>	114	169	13	3	012091450	25,740	<b>18</b>	130	191	13	1	012091800	41,431
14,75	114	169	13	3	012091475	33,255	18,5	135	198	13	1	012091850	45,095
<b>15</b>	114	169	13	3	012091500	30,232	<b>19</b>	135	198	13	1	012091900	46,575
15,25	120	178	13	3	012091525	36,391	19,5	140	205	13	1	012091950	48,800
<b>15,5</b>	120	178	13	3	012091550	33,079	<b>20</b>	140	205	13	1	012092000	51,129

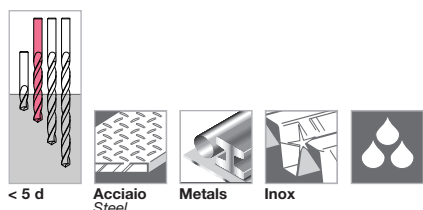

**Velocità di taglio consigliata / Recommended cutting speed**  
**Acciaio / Steel - 10 m/min**  
**Inox - 5 m/min**

Taglio dei materiali con  $R \leq 850 \text{ N/mm}^2$  quali acciai legati, ghise, tutti i metalli in genere, la grafite. Precisione di foratura e costanza di rendimenti elevati.  
 High precision and high performances in cutting alloy steel up to  $R \leq 850 \text{ N/mm}^2$  / Pour percer métaux et acier avec  $R \leq 850 \text{ N/mm}^2$  / Para taladrar hierro e acero  $R \leq 850 \text{ N/mm}^2$  / Einsatz in Stahl und Stahlguss, legiert und unlegiert bis  $R \leq 850 \text{ N/mm}^2$  Zug-Festigkeit, Ne-Metalle, Kunststoffe

## 01207

### Punte elicoidali cilindriche rettificate, serie extra corta "Dual Performer<sup>®</sup>"

Straight shank twist drills, stub serie "Dual Performer<sup>®</sup>" / Forets cylindriques, série extra courte "Dual Performer<sup>®</sup>"

Brocas helicoidales, serie extra corta "Dual Performer<sup>®</sup>" / Geschliffene Spiralbohrer, extra kurz "Dual Performer<sup>®</sup>"

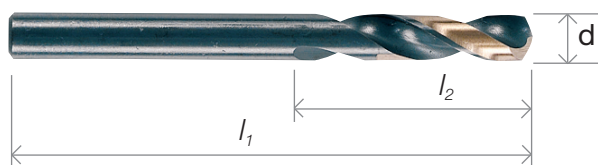
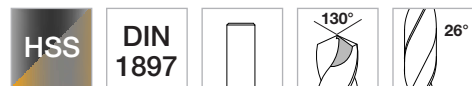

d h8	$l_2$	$l_1$		cod.	€ cad/each
3	16	46	10	012070300	1,418
3,25	18	49	10	012070325	1,490
3,5	20	52	10	012070350	1,490
3,75	20	52	10	012070375	1,490
4	22	55	10	012070400	1,490
4,25	22	55	10	012070425	1,884
4,5	24	58	10	012070450	1,884
4,75	24	58	10	012070475	1,998
5	26	62	10	012070500	1,998
5,25	26	62	10	012070525	2,494
5,5	28	66	10	012070550	2,494
5,75	28	66	10	012070575	2,753
6	28	66	10	012070600	2,753

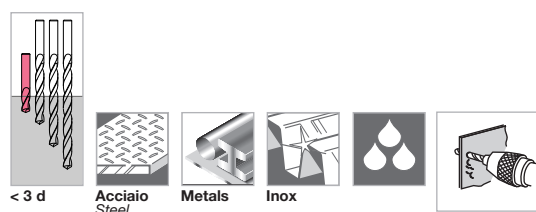

**Velocità di taglio consigliata / Recommended cutting speed**  
**Acciaio / Steel - 10 m/min**  
**Inox - 5 m/min**

Taglio dei materiali con  $R \leq 850 \text{ N/mm}^2$  quali acciai legati, ghise, tutti i metalli in genere, la grafite. Precisione di foratura e costanza di rendimenti elevati.  
 High precision and high performances in cutting alloy steel up to  $R \leq 850 \text{ N/mm}^2$  / Puor percer métaux et acier avec  $R \leq 850 \text{ N/mm}^2$  / Para taladrar hierro e acero  
 $R \leq 850 \text{ N/mm}^2$  / Einsatz in Stahl und Stahlguss, legiert und unlegiert bis  $R \leq 850 \text{ N/mm}^2$  Zug-Festigkeit, Ne-Metalle, Kunststoffe

# 01208

## Punte elicoidali cilindriche rettificate, serie lunga "Dual Performer®"

Long straight shank twist drills "Dual Performer®" / Forets cylindriques série longue "Dual Performer®"

Brocas helicoidales serie larga "Dual Performer®" / Spiralbohrer, lange Ausführung "Dual Performer®"

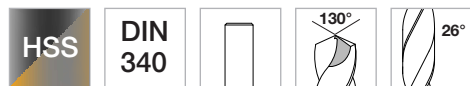

d	$l_2$	$l_1$		cod.	€ cad/each
<b>h8</b>					
<b>3</b>	66	100	10	012080300	2,743
3,25	69	106	10	012080325	2,857
<b>3,5</b>	73	112	10	012080350	2,857
3,75	73	112	10	012080375	2,857
<b>4</b>	78	119	10	012080400	2,857
4,25	78	119	10	012080425	3,633
<b>4,5</b>	82	126	10	012080450	3,633
4,75	82	126	10	012080475	3,923
<b>5</b>	87	132	10	012080500	3,923
5,25	87	132	10	012080525	4,802
<b>5,5</b>	91	139	10	012080550	4,802

d	$l_2$	$l_1$		cod.	€ cad/each
<b>h8</b>					
5,75	91	139	10	012080575	5,299
<b>6</b>	91	139	10	012080600	5,299
6,5	97	148	5	012080650	6,562
<b>7</b>	102	156	5	012080700	7,193
7,5	102	156	5	012080750	7,814
<b>8</b>	109	165	5	012080800	9,833
8,5	109	165	5	012080850	12,617
<b>9</b>	115	175	5	012080900	12,617
9,5	115	175	5	012080950	14,097
<b>10</b>	121	184	5	012081000	15,504

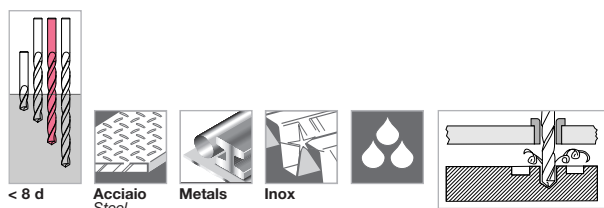

**Velocità di taglio consigliata / Recommended cutting speed**  
**Acciaio / Steel - 10 m/min**  
**Inox - 5 m/min**

Taglio dei materiali con  $R \leq 850 \text{ N/mm}^2$  quali acciai legati, ghise, tutti i metalli in genere, la grafite. Precisione di foratura e costanza di rendimenti elevati.  
 High precision and high performances in cutting alloy steel up to  $R \leq 850 \text{ N/mm}^2$  / Puor percer métaux et acier avec  $R \leq 850 \text{ N/mm}^2$  / Para taladrar hierro e acero  
 $R \leq 850 \text{ N/mm}^2$  / Einsatz in Stahl und Stahlguss, legiert und unlegiert bis  $R \leq 850 \text{ N/mm}^2$  Zug-Festigkeit, Ne-Metalle, Kunststoffe

## 01220

### Punte elicoidali cilindriche rettificate a doppio conoide Speedmaster<sup>®</sup>

HSS-G fully ground twist drills "Speedmaster<sup>®</sup>" / Forets cylindriques rectifiés "Speedmaster<sup>®</sup>"

Brocas helicoidales rectificadas "Speedmaster<sup>®</sup>" / Geschliffene Spiralbohrer "Speedmaster<sup>®</sup>"

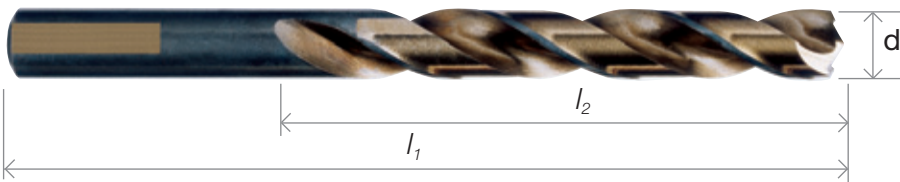
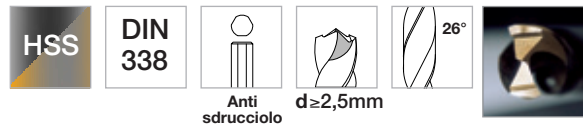

d	l <sub>2</sub>	l <sub>1</sub>		cod.	€ cad/each
h8					
1	12	34	10	012200100	1,377
1,25	16	38	10	012200125	1,511
1,5	18	40	10	012200150	1,377
1,75	22	46	10	012200175	1,511
2	24	49	10	012200200	1,377
2,25	27	53	10	012200225	1,532
2,5	30	57	10	012200250	1,397
2,75	33	61	10	012200275	1,646
3	33	61	10	012200300	1,490
3,25	36	65	10	012200325	1,925
3,5	39	70	10	012200350	1,749
3,75	39	70	10	012200375	2,122
4	43	75	10	012200400	1,925
4,25	43	75	10	012200425	2,298
4,5	47	80	10	012200450	2,080
4,75	47	80	10	012200475	2,629
5	52	86	10	012200500	2,505
5,1	52	86	10	012200510	3,405
5,25	52	86	10	012200525	3,405
5,5	57	93	10	012200550	3,157
5,75	57	93	10	012200575	3,695
6	57	93	10	012200600	3,364
6,25	63	101	10	012200625	4,357
6,5	63	101	10	012200650	3,964
6,75	69	109	10	012200675	5,103

d	l <sub>2</sub>	l <sub>1</sub>		cod.	€ cad/each
h8					
7	69	109	10	012200700	4,637
7,25	69	109	5	012200725	5,465
7,5	69	109	5	012200750	4,958
7,75	75	117	5	012200775	6,417
8	75	117	5	012200800	6,107
8,25	75	117	5	012200825	7,017
8,5	75	117	5	012200850	6,603
8,75	81	125	5	012200875	8,321
9	81	125	5	012200900	7,556
9,25	81	125	5	012200925	8,818
9,5	81	125	5	012200950	8,280
9,75	87	133	5	012200975	9,977
10	87	133	5	012201000	9,512
10,25	87	133	5	012201025	11,012
10,5	87	133	5	012201050	10,298
10,75	94	142	5	012201075	12,782
11	94	142	5	012201100	11,623
11,25	94	142	5	012201125	13,900
11,5	94	142	5	012201150	12,627
11,75	94	142	5	012201175	15,494
12	101	151	5	012201200	14,500
12,25	101	151	5	012201225	16,715
12,5	101	151	5	012201250	15,546
12,75	101	151	5	012201275	17,802
13	101	151	5	012201300	16,622

**Micropunta autocentrante:**  
Facile centratura sul pezzo e agevole partenza del taglio.  
*Micro self-centering tip:*  
Easiness of spot-drilling and start cut.

**Doppia coppia di taglienti con spoglia variabile:**  
Massima capacità di taglio con grande durata del filo tagliente.  
*Double couple of cutting edges with variable relief:* Maximum cutting capacity, with high resistance of the cutting edges.

**Coppia di rompitrucciolo:**  
Evita la formazione di taglienti di riporto.  
*Double chip-breaker:*  
Avoid the creation of built-up cutting edges.

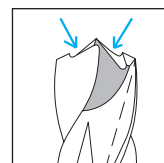
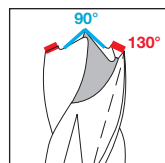
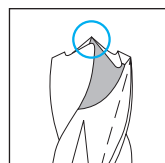
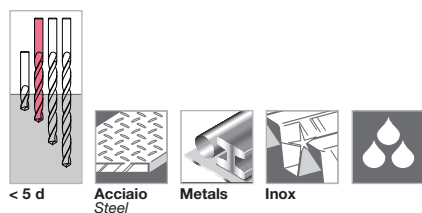

Abs

Taglio altamente professionale con trapani portatili o stazionari in: acciai legati ed altamente legati, acciaio inox fino a R ≤ 900 N/mm<sup>2</sup>, ferro, alluminio, metalli. High quality cuts with portable or bench drilling machines into: alloy steel, high alloy steel, stainless steel up to R ≤ 900 N/mm<sup>2</sup>, iron, aluminium, metals. / Très professionnel découpage avec trépan portatifs ou (stationnaires) en: acier, acier inox jusqu'à R ≤ 900 N/mm<sup>2</sup>, fer, aluminium et métaux. / Corte altamente professionale con taladros portatiles o estacionarios en: aceros aleados y altamente aleados, acero inox hasta R ≤ 900 N/mm<sup>2</sup>, hierro, aluminio, metales. / Beruflicher Schnitt mit tragbaren Bohrers in: legiert und unlegiert Stahl, rostfreier Stahl bis R ≤ 900 N/mm<sup>2</sup>, Aluminium, Eisen.

19 pcs - Ø 1÷10 x 0,5 mm  
01229301 € 78,360  
25 pcs - Ø 1÷13 x 0,5 mm  
01229302 € 162,319

# 01139

**Punte elicoidali al cobalto 5% con elica rapida tipo W, per il taglio degli acciai inox, acciai resistenti al calore ed austenitici (V2A-V4A)** Cobalt twist drill with W type flute to cut stainless steel, heat resistant steel, austenitic steel (V2A-V4A) / Forets cylindriques HSS-CO avec eliche especial W / Brocas helicoidales HSS-CO con elica especial W

**HSS  
CO 5**

**DIN  
338**



d ≥ 3mm



Type W

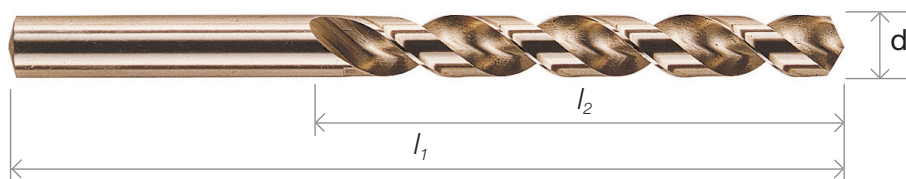

d h8	l <sub>2</sub>	l <sub>1</sub>		cod.	€ cad/each
1	12	34	10	011390100	2,298
1,25	16	38	10	011390125	2,298
1,5	18	40	10	011390150	1,801
1,75	22	46	10	011390175	2,060
2	24	49	10	011390200	1,635
2,25	27	53	10	011390225	1,801
2,5	30	57	10	011390250	1,801
2,75	33	61	10	011390275	1,801
2,8	33	61	10	011390280	1,801
3	33	61	10	011390300	1,801
3,2	36	65	10	011390320	1,801
3,25	36	65	10	011390325	2,142
3,3	36	65	10	011390330	2,142
3,4	39	70	10	011390340	2,215
3,5	39	70	10	011390350	2,215
3,7	39	70	10	011390370	2,298
3,75	39	70	10	011390375	2,619
3,8	43	75	10	011390380	2,619
4	43	75	10	011390400	2,474
4,1	43	75	10	011390410	2,712
4,2	43	75	10	011390420	2,712
4,25	43	75	10	011390425	2,877
4,5	47	80	10	011390450	2,784
4,75	47	80	10	011390475	3,047
4,8	52	86	10	011390480	3,047
5	52	86	10	011390500	3,047
5,2	52	86	10	011390520	3,364
5,25	52	86	10	011390525	3,364
5,5	57	93	10	011390550	4,099
5,75	57	93	10	011390575	4,099

d h8	l <sub>2</sub>	l <sub>1</sub>		cod.	€ cad/each
6	57	93	10	011390600	4,099
6,25	63	101	10	011390625	6,614
6,5	63	101	10	011390650	7,090
6,75	69	109	10	011390675	9,098
7	69	109	10	011390700	8,497
7,25	69	109	5	011390725	9,563
7,5	69	109	5	011390750	9,563
7,75	75	117	5	011390775	10,257
8	75	117	5	011390800	10,257
8,25	75	117	5	011390825	10,971
8,5	75	117	5	011390850	10,857
8,75	81	125	5	011390875	13,331
9	81	125	5	011390900	13,331
9,25	81	125	5	011390925	14,397
9,5	81	125	5	011390950	14,397
9,75	87	133	5	011390975	15,804
10	87	133	5	011391000	15,804
10,25	87	133	5	011391025	19,820
10,5	87	133	5	011391050	19,820
10,75	94	142	5	011391075	23,236
11	94	142	5	011391100	23,236
11,25	94	142	5	011391125	24,302
11,5	94	142	5	011391150	24,302
11,75	94	142	5	011391175	26,879
12	101	151	5	011391200	26,879
12,25	101	151	5	011391225	29,353
12,5	101	151	5	011391250	29,353
12,75	101	151	5	011391275	29,953
13	101	151	5	011391300	29,953

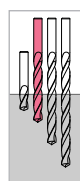

< 5 d



Inox



Acciaio  
Steel



Metals



**Velocità di taglio consigliata / Recommended cutting speed**  
**Acciaio / Steel - 12 m/min**  
**Inox - 6 m/min**



**Abs**

19 pcs - Ø 1÷10 x 0,5 mm  
**01155303 € 117,845**

25 pcs - Ø 1÷13 x 0,5 mm  
**01155304 € 271,387**

Punte con ottima resistenza alle sollecitazioni termiche, adatte per forare acciai legati e non con R sino a 1200 N/mm<sup>2</sup>, in modo particolare acciai da bonifica, acciai per lavorazioni a caldo e a freddo, acciai inossidabili, ghisa etc. High performance in cutting alloy steel, cast iron, stainless steel and metals up to R ≤ 1200 N/mm<sup>2</sup>. / Pour percer l'acier allié, la fonte, l'acier inox avec R ≤ 1200 N/mm<sup>2</sup>. / Para taladar acero aleado, acero inox, fundicion R ≤ 1200 N/mm<sup>2</sup>. / Einsatz in legierte Stahl bis R ≤ 1200 N/mm<sup>2</sup> Zug-Festigkeit, Korrosionsbeständige Stähle, Grauguss und Stahlguss.



## 01145

### Punte elicoidali al cobalto 5%, esecuzione interamente rettificata, serie corta

Cobalt twist drills ground from the solid / Forets cylindriques au cobalt entièrement rectifiés

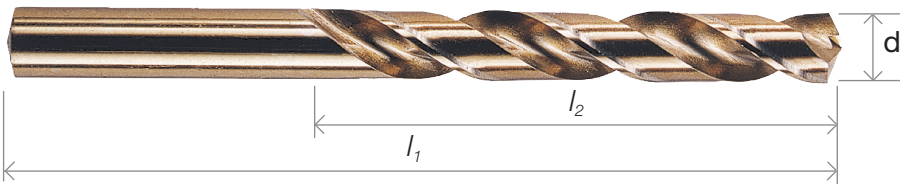
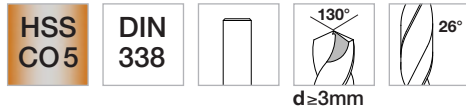
Broca helicoidal rectificada de cobalto / Kobalt Spiralbohrer



d	l <sub>2</sub>	l <sub>1</sub>		cod.	€ cad/each	d	l <sub>2</sub>	l <sub>1</sub>		cod.	€ cad/each
h8						h8					
0,3	3	19	10	011450030	2,236	2	24	49	10	011450200	1,377
0,35	4	19	10	011450035	2,236	2,1	24	49	10	011450210	1,677
0,4	5	20	10	011450040	2,236	2,2	27	53	10	011450220	1,677
0,45	5	20	10	011450045	2,236	2,25	27	53	10	011450225	1,677
0,5	6	22	10	011450050	2,236	2,3	27	53	10	011450230	1,677
0,55	7	24	10	011450055	2,236	2,4	30	57	10	011450240	1,677
0,6	7	24	10	011450060	2,236	2,5	30	57	10	011450250	1,449
0,65	8	26	10	011450065	2,236	2,6	30	57	10	011450260	1,594
0,7	9	28	10	011450070	2,236	2,7	33	61	10	011450270	1,594
0,75	9	28	10	011450075	2,236	2,75	33	61	10	011450275	1,594
0,8	10	30	10	011450080	2,236	2,8	33	61	10	011450280	1,594
0,85	10	30	10	011450085	2,236	2,9	33	61	10	011450290	1,594
0,9	11	32	10	011450090	2,236	3	33	61	10	011450300	1,449
0,95	11	32	10	011450095	2,236	3,1	36	65	10	011450310	1,987
1	12	34	10	011450100	1,428	3,2	36	65	10	011450320	1,987
1,1	14	36	10	011450110	1,584	3,25	36	65	10	011450325	1,987
1,2	16	38	10	011450120	1,584	3,3	36	65	10	011450330	1,987
1,25	16	38	10	011450125	1,584	3,4	39	70	10	011450340	1,987
1,3	16	38	10	011450130	1,584	3,5	39	70	10	011450350	1,801
1,4	18	40	10	011450140	1,584	3,6	39	70	10	011450360	2,349
1,5	18	40	10	011450150	1,428	3,7	39	70	10	011450370	2,349
1,6	20	43	10	011450160	1,511	3,75	39	70	10	011450375	2,349
1,7	20	43	10	011450170	1,511	3,8	43	75	10	011450380	2,349
1,75	22	46	10	011450175	1,511	3,9	43	75	10	011450390	2,349
1,8	22	46	10	011450180	1,511	4	43	75	10	011450400	2,142
1,9	22	46	10	011450190	1,511	4,1	43	75	10	011450410	2,701

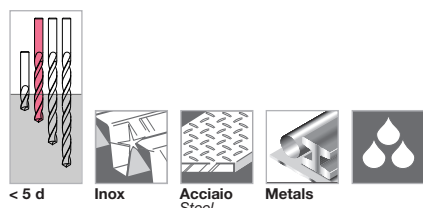

**Velocità di taglio consigliata / Recommended cutting speed**  
**Acciaio / Steel - 12 m/min**  
**Inox - 6 m/min**



Punte con ottima resistenza alle sollecitazioni termiche, adatte per forare acciai legati e non con R sino a 1200 N/mm<sup>2</sup>, in modo particolare acciai da bonifica, acciai per lavorazioni a caldo e a freddo, acciai inossidabili, ghisa etc. High performance in cutting alloy steel, cast iron, stainless steel and metals up to R ≤ 1200 N/mm<sup>2</sup>. / Pour percer l'acier allié, la fonte, l'acier inox avec R ≤ 1200 N/mm<sup>2</sup>. / Para taladar acero aleado, acero inox, fundicion R ≤ 1200 N/mm<sup>2</sup>. / Einsatz in legierte Stahl bis R ≤ 1200 N/mm<sup>2</sup> Zug-Festigkeit, Korrosionsbeständige Stähle, Grauguss und Stahlguss.

19 pcs - Ø 1÷10 x 0,5 mm  
**01155301 € 77,242**  
 25 pcs - Ø 1÷13 x 0,5 mm  
**01155302 € 154,484**

d h8	$l_2$	$l_1$		cod.	€ cad/each
4,2	43	75	10	011450420	2,701
<b>4,25</b>	43	75	10	011450425	2,701
4,3	47	80	10	011450430	2,701
4,4	47	80	10	011450440	2,701
<b>4,5</b>	47	80	10	011450450	2,453
4,6	47	80	10	011450460	2,846
4,7	47	80	10	011450470	2,846
<b>4,75</b>	47	80	10	011450475	2,846
4,8	52	86	10	011450480	2,846
4,9	52	86	10	011450490	2,846
<b>5</b>	52	86	10	011450500	2,588
5,1	52	86	10	011450510	3,467
5,2	52	86	10	011450520	3,467
<b>5,25</b>	52	86	10	011450525	3,467
5,3	52	86	10	011450530	3,467
5,4	57	93	101	011450540	3,467
<b>5,5</b>	57	93	0	011450550	3,302
5,6	57	93	10	011450560	3,995
5,7	57	93	10	011450570	3,995
<b>5,75</b>	57	93	10	011450575	3,995
5,8	57	93	10	011450580	3,995
5,9	57	93	10	011450590	3,995
<b>6</b>	57	93	10	011450600	3,664
6,1	63	101	10	011450610	4,709
6,2	63	101	10	011450620	4,709
<b>6,25</b>	63	101	10	011450625	4,709
6,3	63	101	10	011450630	4,709
6,4	63	101	10	011450640	4,709
<b>6,5</b>	63	101	10	011450650	4,357
6,6	63	101	10	011450660	5,755
6,7	63	101	10	011450670	5,755
<b>6,75</b>	69	109	10	011450675	5,755
6,8	69	109	101	011450680	5,755
6,9	69	109	0	011450690	5,755
<b>7</b>	69	109	10	011450700	5,320
7,1	69	109	5	011450710	6,417
7,2	69	109	5	011450720	6,417
<b>7,25</b>	69	109	5	011450725	6,417
7,3	69	109	5	011450730	6,417
7,4	69	109	5	011450740	6,417
<b>7,5</b>	69	109	5	011450750	5,837
7,6	75	117	5	011450760	7,556
7,7	75	117	5	011450770	7,556
<b>7,75</b>	75	117	5	011450775	7,556
7,8	75	117	5	011450780	7,556
7,9	75	117	5	011450790	7,556
<b>8</b>	75	117	5	011450800	6,872
8,1	75	117	5	011450810	8,001
8,2	75	117	5	011450820	8,001
<b>8,25</b>	75	117	5	011450825	8,001
8,3	75	117	5	011450830	8,001
8,4	75	117	5	011450840	8,001

d h8	$l_2$	$l_1$		cod.	€ cad/each
<b>8,5</b>	75	117	5	011450850	7,276
8,6	81	125	5	011450860	9,781
8,7	81	125	5	011450870	9,781
<b>8,75</b>	81	125	5	011450875	9,781
8,8	81	125	5	011450880	9,781
8,9	81	125	5	011450890	9,781
<b>9</b>	81	125	5	011450900	8,891
9,1	81	125	5	011450910	10,236
9,2	81	125	5	011450920	10,236
<b>9,25</b>	81	125	5	011450925	10,236
9,3	81	125	5	011450930	10,236
9,4	81	125	5	011450940	10,236
<b>9,5</b>	81	125	5	011450950	9,305
9,6	87	133	5	011450960	11,882
9,7	87	133	5	011450970	11,882
<b>9,75</b>	87	133	5	011450975	11,882
9,8	87	133	5	011450980	11,882
9,9	87	133	5	011450990	11,882
<b>10</b>	87	133	5	011451000	10,805
10,25	87	133	5	011451025	14,148
10,5	87	133	5	011451050	12,865
10,75	94	142	5	011451075	16,001
<b>11</b>	94	142	5	011451100	14,542
11,25	94	142	5	011451125	17,440
11,5	94	142	5	011451150	15,856
11,75	94	142	5	011451175	19,199
<b>12</b>	101	151	5	011451200	17,450
12,25	101	151	5	011451225	20,762
12,5	101	151	5	011451250	18,878
12,75	101	151	5	011451275	22,615
<b>13</b>	101	151	5	011451300	20,555
13,25	108	160	3	011451325	32,603
13,5	108	160	3	011451350	32,603
13,75	108	160	3	011451375	34,362
<b>14</b>	108	160	3	011451400	34,362
14,25	114	169	3	011451425	37,902
14,5	114	169	3	011451450	37,902
14,75	114	169	3	011451475	39,848
<b>15</b>	114	169	3	011451500	39,848
15,25	120	178	3	011451525	45,851
15,5	120	178	3	011451550	45,851
15,75	120	178	3	011451575	46,958
<b>16</b>	120	178	3	011451600	46,958
16,5	125	184	1	011451650	47,765
<b>17</b>	125	184	1	011451700	47,765
17,5	130	191	1	011451750	61,997
<b>18</b>	130	191	1	011451800	61,997
18,5	135	198	1	011451850	71,187
<b>19</b>	135	198	1	011451900	71,187
19,5	140	205	1	011451950	82,241
<b>20</b>	140	205	1	011452000	82,241



## 01155

### Assortimenti punte al cobalto 5% in scatole di metallo

Sets of cobalt twist drills / Assortiments forets au cobalt

Juego brocas de cobalto / Kobalt-geschliffene Spiralbohrersätze

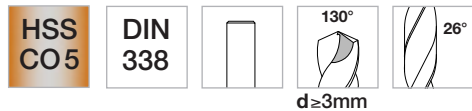

Metal

49 pcs - Ø 1÷13 x 0,25 mm

01155412 € 379,493

37 pcs - Ø 1÷10 x 0,25 mm

01155411 € 174,636

51 pcs - Ø 1÷6 x 0,1 mm

01155403 € 117,545

41 pcs - Ø 6÷10 x 0,1 mm

01155404 € 319,049

91 pcs - Ø 1÷10 x 0,1 mm

01155410 € 545,176

91 pcs - Ø 1÷10 x 0,1 mm **Plastic box**

01155220 € 433,230

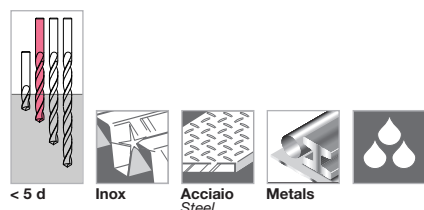

**Velocità di taglio consigliata / Recommended cutting speed**  
**Acciaio / Steel - 12 m/min**  
**Inox - 6 m/min**



Punte con ottima resistenza alle sollecitazioni termiche, adatte per forare acciai legati e non con R sino a 1200 N/mm<sup>2</sup>, in modo particolare acciai da bonifica, acciai per lavorazioni a caldo e a freddo, acciai inossidabili, ghisa etc. High performance in cutting alloy steel, cast iron, stainless steel and metals up to R ≤ 1200 N/mm<sup>2</sup>. / Pour percer l'acier allié, la fonte, l'acier inox avec R ≤ 1200 N/mm<sup>2</sup>. / Para taladar acero aleado, acero inox, fundicion R ≤ 1200 N/mm<sup>2</sup>. / Einsatz in legierte Stahl bis R ≤ 1200 N/mm<sup>2</sup> Zug-Festigkeit, Korrosionsbeständige Stähle, Grauguss und Stahlguss.

# 01155

## Assortimenti punte al cobalto 5% in scatole di metallo

Sets of cobalt twist drills / Assortiments forets au cobalt

Juego brocas de cobalto / Kobalt-geschliffene Spiralbohrersätze

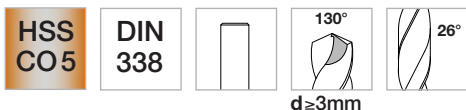

Metal

116 pcs - Ø 1÷10 x 0,5 mm  
Ø 1 ÷ 5 mm - 10 pcs  
Ø 5,5 ÷ 8 mm - 3 pcs  
Ø 8,5 ÷ 10 mm - 2 pcs

01155450 € 320,167

331x228x48

128 pcs - Ø 1÷13 x 0,5 mm  
Ø 1 ÷ 5 mm - 10 pcs  
Ø 5,5 ÷ 8 mm - 3 pcs  
Ø 8,5 ÷ 13 mm - 2 pcs

01155451 € 625,771

497x266x59

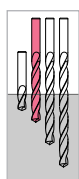

<math>d</math>



Inox



Acciaio  
Steel



Metals



Velocità di taglio consigliata / Recommended cutting speed

Acciaio / Steel - 12 m/min

Inox - 6 m/min

Punte con ottima resistenza alle sollecitazioni termiche, adatte per forare acciai legati e non con R sino a 1200 N/mm<sup>2</sup>, in modo particolare acciai da bonifica, acciai per lavorazioni a caldo e a freddo, acciai inossidabili, ghisa etc. High performance in cutting alloy steel, cast iron, stainless steel and metals up to R ≤ 1200 N/mm<sup>2</sup>. / Pour percer l'acier allié, la fonte, l'acier inox avec R ≤ 1200 N/mm<sup>2</sup>. / Para taladar acero aleado, acero inox, fundicion R ≤ 1200 N/mm<sup>2</sup>. / Einsatz in legierte Stahl bis R ≤ 1200 N/mm<sup>2</sup> Zug-Festigkeit, Korrosionsbeständige Stähle, Grauguss und Stahlguss.

## 01147

### Punte elicoidali al cobalto 5% con codolo ridotto, esecuzione rettificata, serie corta

Reduced shank twist drills / Forets cylindriques à queue réduite

Brocas helicoidales con mango reducido / Geschliffene Spiralbohrer mit reduzierten Schaft

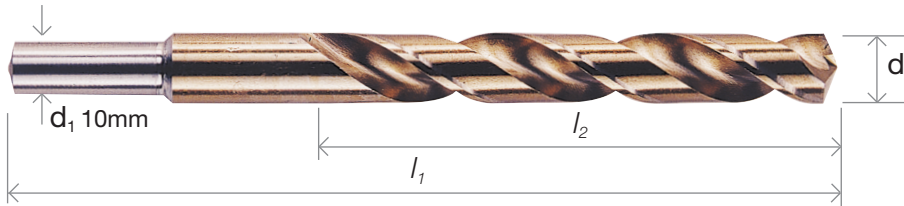
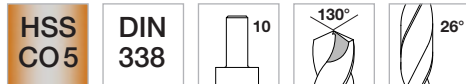

d	l <sub>2</sub>	l <sub>1</sub>	d <sub>1</sub>		cod.	€ cad/each
h8						
10,25	87	133	10	5	011471025	16,498
<b>10,5</b>	87	133	10	5	011471050	15,215
10,75	94	142	10	5	011471075	18,351
<b>11</b>	94	142	10	5	011471100	16,891
11,25	94	142	10	5	011471125	19,789
<b>11,5</b>	94	142	10	5	011471150	18,206
11,75	94	142	10	5	011471175	21,549
<b>12</b>	101	151	10	5	011471200	19,800
12,25	101	151	10	5	011471225	23,122
<b>12,5</b>	101	151	10	5	011471250	21,228
12,75	101	151	10	5	011471275	24,964
<b>13</b>	101	151	10	5	011471300	22,905
13,25	108	160	10	3	011471325	35,501
<b>13,5</b>	108	160	10	3	011471350	35,501
13,75	108	160	10	3	011471375	36,432
<b>14</b>	108	160	10	3	011471400	36,432

d	l <sub>2</sub>	l <sub>1</sub>	d <sub>1</sub>		cod.	€ cad/each
h8						
14,25	114	169	10	3	011471425	41,193
<b>14,5</b>	114	169	10	3	011471450	41,193
14,75	114	169	10	3	011471475	42,539
<b>15</b>	114	169	10	3	011471500	42,539
15,25	120	178	10	3	011471525	49,473
<b>15,5</b>	120	178	10	3	011471550	49,473
15,75	120	178	10	3	011471575	51,253
<b>16</b>	120	178	10	3	011471600	51,253
16,5	125	184	10	1	011471650	52,061
<b>17</b>	125	184	10	1	011471700	52,061
17,5	130	191	10	1	011471750	67,016
<b>18</b>	130	191	10	1	011471800	67,016
18,5	135	198	10	1	011471850	76,921
<b>19</b>	135	198	10	1	011471900	76,921
19,5	140	205	10	1	011471950	89,476
<b>20</b>	140	205	10	1	011472000	89,476

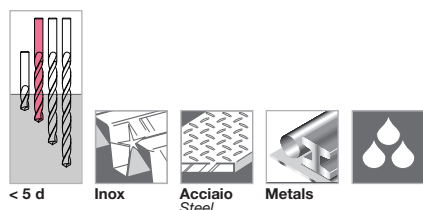

**Velocità di taglio consigliata / Recommended cutting speed**  
**Acciaio / Steel - 12 m/min**  
**Inox - 6 m/min**

Punte con ottima resistenza alle sollecitazioni termiche, adatte per forare acciai legati e non con R sino a 1200 N/mm<sup>2</sup>, in modo particolare acciai da bonifica, acciai per lavorazioni a caldo e a freddo, acciai inossidabili, ghisa etc. High performance in cutting alloy steel, cast iron, stainless steel and metals up to R ≤ 1200 N/mm<sup>2</sup>. / Pour percer l'acier allié, la fonte, l'acier inox avec R ≤ 1200 N/mm<sup>2</sup>. / Para taladar acero aleado, acero inox, fundicion R ≤ 1200 N/mm<sup>2</sup>. / Einsatz in legierte Stahl bis R ≤ 1200 N/mm<sup>2</sup> Zug-Festigkeit, Korrosionsbeständige Stähle, Grauguss und Stahlguss.

# 01146

## Punte elicoidali al cobalto 5% con codolo ridotto, esecuzione rettificata, serie corta

Reduced shank twist drills / Forets cylindriques à queue réduite

Brocas helicoidales con mango reducido / Geschliffene Spiralbohrer mit reduzierten Schaft

HSS  
CO5

DIN  
338

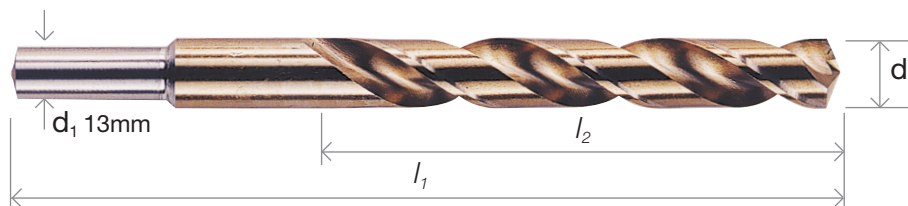

d	$l_2$	$l_1$	$d_1$		cod.	€ cad/each	d	$l_2$	$l_1$	$d_1$		cod.	€ cad/each
h8							h8						
13,25	108	160	13	3	011461325	35,501	15,75	120	178	13	3	011461575	51,253
<b>13,5</b>	108	160	13	3	011461350	35,501	<b>16</b>	120	178	13	3	011461600	51,253
13,75	108	160	13	3	011461375	36,432	16,5	125	184	13	1	011461650	52,061
<b>14</b>	108	160	13	3	011461400	36,432	<b>17</b>	125	184	13	1	011461700	52,061
14,25	114	169	13	3	011461425	41,193	17,5	130	191	13	1	011461750	67,016
<b>14,5</b>	114	169	13	3	011461450	41,193	<b>18</b>	130	191	13	1	011461800	67,016
14,75	114	169	13	3	011461475	42,539	18,5	135	198	13	1	011461850	76,921
<b>15</b>	114	169	13	3	011461500	42,539	<b>19</b>	135	198	13	1	011461900	76,921
15,25	120	178	13	3	011461525	49,473	19,5	140	205	13	1	011461950	89,476
<b>15,5</b>	120	178	13	3	011461550	49,473	<b>20</b>	140	205	13	1	011462000	89,476

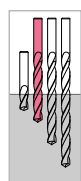

< 5 d



Innox



Acciaio  
Steel



Metals



**Velocità di taglio consigliata / Recommended cutting speed**  
**Acciaio / Steel - 12 m/min**  
**Inox - 6 m/min**

Punte con ottima resistenza alle sollecitazioni termiche, adatte per forare acciai legati e non con R sino a 1200 N/mm<sup>2</sup>, in modo particolare acciai da bonifica, acciai per lavorazioni a caldo e a freddo, acciai inossidabili, ghisa etc. High performance in cutting alloy steel, cast iron, stainless steel and metals up to R ≤ 1200 N/mm<sup>2</sup>. / Pour percer l'acier allié, la fonte, l'acier inox avec R ≤ 1200 N/mm<sup>2</sup>. / Para taladar acero aleado, acero inox, fundicion R ≤ 1200 N/mm<sup>2</sup>. / Einsatz in legierte Stahl bis R ≤ 1200 N/mm<sup>2</sup> Zug-Festigkeit, Korrosionsbeständige Stähle, Grauguss und Stahlguss.

## 01149

### Punte elicoidali al cobalto 5%, serie extra corta

Cobalt straight shank twist drills, stub serie / Forets au cobalt, série extra courte  
Broca de cobalto, serie extra corta / Kobalt Spiralbohrer, extra kurz

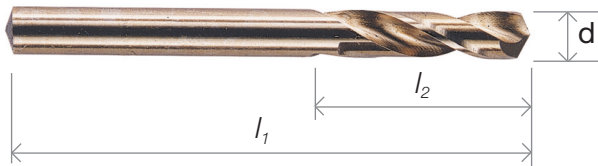
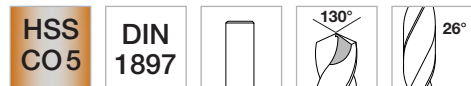

d h8	$l_2$	$l_1$		cod.	€ cad/each
3	16	46	10	011490300	1,832
3,25	18	49	10	011490325	2,329
3,5	20	52	10	011490350	2,329
3,75	20	52	10	011490375	2,567
4	22	55	10	011490400	2,567
4,25	22	55	10	011490425	2,929
4,5	24	58	10	011490450	2,929
4,75	24	58	10	011490475	3,115
5	26	62	10	011490500	3,115
5,5	28	66	10	011490550	4,233
6	28	66	10	011490600	4,399

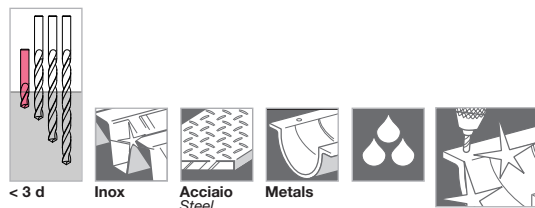

Velocità di taglio consigliata / Recommended cutting speed  
Acciaio / Steel - 12 m/min  
Inox - 6 m/min

Punte con ottima resistenza alle sollecitazioni termiche, adatte per forare acciai legati e non con R sino a 1200 N/mm<sup>2</sup>, in modo particolare acciai da bonifica, acciai per lavorazioni a caldo e a freddo, acciai inossidabili, ghisa etc. Punte speciali per la foratura di lamiere e tubi in acciaio inox e lamiere metalliche in genere (acciaio, ferro, rame). Speciali per lattonieri, carpentieri, coperturisti, fabbri, installatori. High performance in cutting alloy steel, cast iron, stainless steel and metals up to R ≤ 1200 N/mm<sup>2</sup>. Super short twist drills for cutting stainless metal sheets. Special for journeymen's, carpenters, locksmith's, tinsmith's. / Pour percer l'acier allié, la fonte, l'acier inox avec R ≤ 1200 N/mm<sup>2</sup>. Forets extra courts pour travailler toles et tubes en inox, spécial pour ferblantiers, charpentiers, forgerons, installateurs. / Para taladar acero aleado, acero inox, fundicion R ≤ 1200 N/mm<sup>2</sup>. Brocas extra cortas para taladrar en chapas de inox, especial para hojalateros, carpinteros, herreros, instaladores/ Einsatz in legierte Stahl bis R ≤ 1200 N/mm<sup>2</sup> Zug-Festigkeit, Korrosionsbeständige Stähle, Grauguss und Stahlguss.

# 01051

## Punte elicoidali al cobalto 5%, serie super corta per lamiera, speciali per lattonieri

Cobalt straight shank twist drills, super short series / Forets au cobalt, série super courte

Broca de cobalto, serie super corta / Kobalt Spiralbohrer, Super kurz

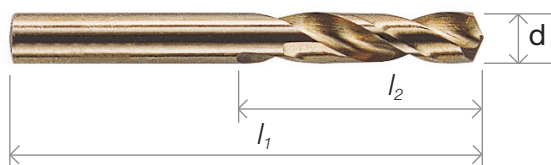
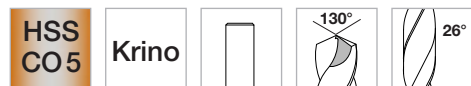

d	$l_2$	$l_1$		cod.	€ cad/each
3	16	35	10	010510300	1,418
3,25	19	40	10	010510325	1,418
3,5	19	40	10	010510350	1,418
3,75	19	40	10	010510375	2,018
4	20	40	10	010510400	2,132
4,25	20	40	10	010510425	2,318
4,5	23	42	10	010510450	2,681
5	23	45	10	010510500	2,970

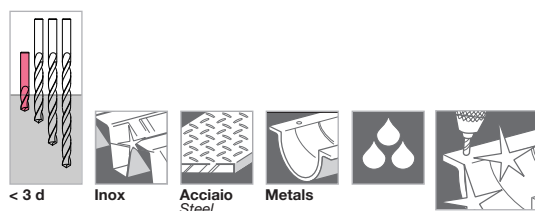

**Velocità di taglio consigliata / Recommended cutting speed**  
**Acciaio / Steel - 12 m/min**  
**Inox - 6 m/min**

Punte con ottima resistenza alle sollecitazioni termiche, adatte per forare acciai legati e non con R sino a 1200 N/mm<sup>2</sup>, in modo particolare acciai da bonifica, acciai per lavorazioni a caldo e a freddo, acciai inossidabili, ghisa etc. Punte speciali per la foratura di lamiera e tubi in acciaio inox e lamiera metalliche in genere (acciaio, ferro, rame). Speciali per lattonieri, carpentieri, coperturisti, fabbri, installatori. High performance in cutting alloy steel, cast iron, stainless steel and metals up to R ≤ 1200 N/mm<sup>2</sup>. Super short twist drills for cutting stainless metal sheets. Special for journeymen's, carpenters, locksmith's, tinsmith's. / Pour percer l'acier allié, la fonte, l'acier inox avec R ≤ 1200 N/mm<sup>2</sup>. Forets extra courts pour travailler toles et tubes en inox, spécial pour ferblantiers, charpentiers, forgerons, installateurs. / Para taladar acero aleado, acero inox, fundicion R ≤ 1200 N/mm<sup>2</sup>. Brocas extra cortas para taladrar en chapas de inox, especial para hojalateros, carpinteros, herreros, instaladores/ Einsatz in legierte Stahl bis R ≤ 1200 N/mm<sup>2</sup> Zug-Festigkeit, Korrosionsbeständige Stähle, Grauguss und Stahlguss.

## 01148

### Punte elicoidali al cobalto 5%, a elica contrapposta

Cobalt straight shank twist drills, double ended / Forets au cobalt  
Broca de cobalto / Kobalt Spiralbohrer

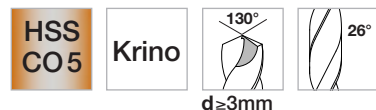

d	l <sub>2</sub>	l <sub>1</sub>		cod.	€ cad/each
2	10	38	10	011480200	2,826
2,5	10	43	10	011480250	2,826
3	10	46	10	011480300	2,826
3,25	10	49	10	011480325	3,612
3,5	12	52	10	011480350	3,271
3,75	12	55	10	011480375	3,871
4	12	55	10	011480400	3,509
4,1	12	55	10	011480410	4,337
4,25	12	58	10	011480425	4,337
4,5	12	58	10	011480450	3,954
4,75	13	62	10	011480475	5,082
4,9	13	62	10	011480490	4,626
5	13	62	10	011480500	4,626
5,1	13	62	10	011480510	5,599
5,5	16	66	10	011480550	5,599
6	16	66	10	011480600	6,624

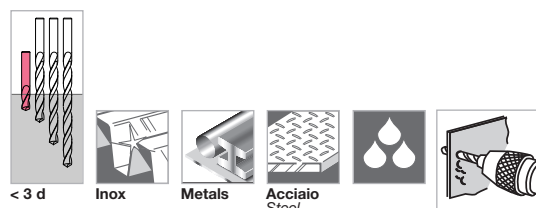

**Velocità di taglio consigliata / Recommended cutting speed**  
**Acciaio / Steel - 12 m/min**  
**Inox - 6 m/min**

Punte con ottima resistenza alle sollecitazioni termiche, adatte per forare acciai legati e non con R sino a 1200 N/mm<sup>2</sup>, in modo particolare acciai da bonifica, acciai per lavorazioni a caldo e a freddo, acciai inossidabili, ghisa etc. High performance in cutting alloy steel, cast iron, stainless steel and metals up to R ≤ 1200 N/mm<sup>2</sup>. / Pour percer l'acier allié, la fonte, l'acier inox avec R ≤ 1200 N/mm<sup>2</sup>. / Para taladar acero aleado, acero inox, fundicion R ≤ 1200 N/mm<sup>2</sup>. / Einsatz in legierte Stahl bis R ≤ 1200 N/mm<sup>2</sup> Zug-Festigkeit, Korrosionsbeständige Stähle, Grauguss und Stahlguss.

# 01152



## Punte elicoidali cilindriche al cobalto 5%, serie lunga

Cobalt long straight shank twist drills / Forets cylindriques série longue au cobalt  
Brocas helicoidales serie larga de cobalto / Kobalt Spiralbohrer, lange Ausführung

HSS  
CO 5

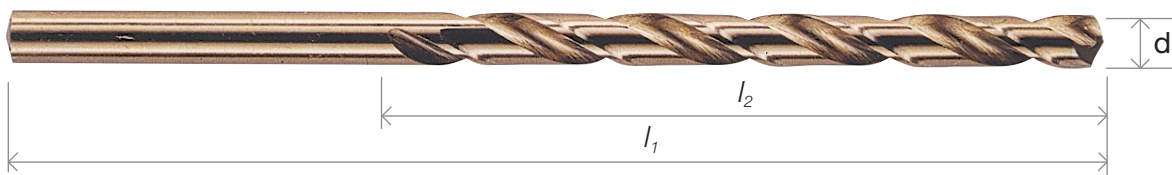
DIN  
340



d h8	$l_2$	$l_1$		cod.	€ cad/each	d h8	$l_2$	$l_1$		cod.	€ cad/each
3	66	100	10	011520300	3,519	5,75	91	139	10	011520575	8,404
3,25	69	106	10	011520325	3,923	6	91	139	10	011520600	8,404
3,5	73	112	10	011520350	3,923	6,5	97	148	5	011520650	10,060
3,75	73	112	10	011520375	4,906	7	102	156	5	011520700	11,685
4	78	119	10	011520400	4,906	7,5	102	156	5	011520750	12,710
4,25	78	119	10	011520425	5,858	8	109	165	5	011520800	15,008
4,5	82	126	10	011520450	5,858	8,5	109	165	5	011520850	15,939
4,75	82	126	10	011520475	6,220	9	115	175	5	011520900	18,630
5	87	132	10	011520500	6,220	9,5	115	175	5	011520950	20,648
5,25	87	132	10	011520525	7,794	10	121	184	5	011521000	24,012
5,5	91	139	10	011520550	7,794						

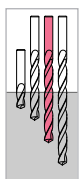

< 8 d



Inox



Acciaio  
Steel



Metals

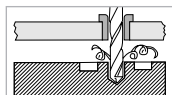

Velocità di taglio consigliata / Recommended cutting speed  
Acciaio / Steel - 12 m/min  
Inox - 6 m/min

Punte con ottima resistenza alle sollecitazioni termiche, adatte per forare acciai legati e non con R sino a 1200 N/mm<sup>2</sup>, in modo particolare acciai da bonifica, acciai per lavorazioni a caldo e a freddo, acciai inossidabili, ghisa etc. High performance in cutting alloy steel, cast iron, stainless steel and metals up to R ≤ 1200 N/mm<sup>2</sup>. / Pour percer l'acier allié, la fonte, l'acier inox avec R ≤ 1200 N/mm<sup>2</sup>. / Para taladar acero aleado, acero inox, fundicion R ≤ 1200 N/mm<sup>2</sup>. / Einsatz in legierte Stahl bis R ≤ 1200 N/mm<sup>2</sup> Zug-Festigkeit, Korrosionsbeständige Stähle, Grauguss und Stahlguss.



## 01300

### Punte elicoidali cilindriche al cobalto rivestite al TiAlN

HSS-CO TiAlN coated twist drills / Forets cylindriques HSS-CO revêtement TiAlN

Brocas helicoidales HSS-CO con recubrimiento de TiAlN / HSS-CO geschliffene Spiralbohrer, TiAlN-beschichtet

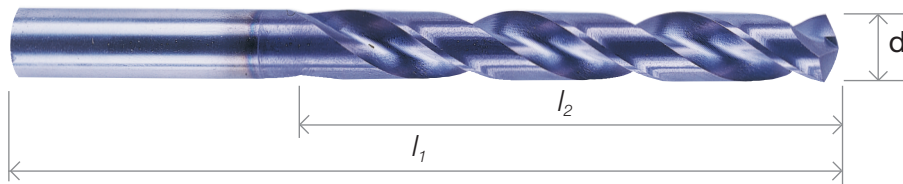
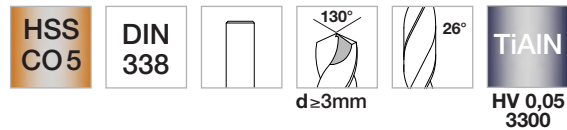

d	l <sub>2</sub>	l <sub>1</sub>		cod.	€ cad/each
h8					
1	12	34	1	013000100	7,317
1,25	16	38	1	013000125	7,514
1,5	18	40	1	013000150	7,514
1,75	22	46	1	013000175	7,369
2	24	49	1	013000200	7,369
2,25	27	53	1	013000225	7,369
2,5	30	57	1	013000250	7,369
2,75	33	61	1	013000275	7,369
3	33	61	1	013000300	7,369
3,2	36	65	1	013000320	7,959
3,25	36	65	1	013000325	7,959
3,5	39	70	1	013000350	7,959
3,75	39	70	1	013000375	8,104
4	43	75	1	013000400	8,104
4,2	43	75	1	013000420	9,853
4,25	43	75	1	013000425	9,853
4,5	47	80	1	013000450	9,853
4,75	47	80	1	013000475	9,853
4,8	52	86	1	013000480	9,853
5	52	86	1	013000500	9,853
5,2	52	86	1	013000520	10,971
5,25	52	86	1	013000525	10,971
5,5	57	93	1	013000550	10,971
5,75	57	93	1	013000575	10,971
6	57	93	1	013000600	10,971
6,25	63	101	1	013000625	15,991
6,5	63	101	1	013000650	15,991

d	l <sub>2</sub>	l <sub>1</sub>		cod.	€ cad/each
h8					
6,75	69	109	1	013000675	16,902
7	69	109	1	013000700	16,902
7,25	69	109	1	013000725	16,902
7,5	69	109	1	013000750	16,902
7,75	75	117	1	013000775	18,061
8	75	117	1	013000800	18,061
8,25	75	117	1	013000825	19,675
8,5	75	117	1	013000850	19,675
8,75	81	125	1	013000875	21,218
9	81	125	1	013000900	21,218
9,25	81	125	1	013000925	21,859
9,5	81	125	1	013000950	21,859
9,75	87	133	1	013000975	24,519
10	87	133	1	013001000	24,519
10,25	87	133	1	013001025	30,232
10,5	87	133	1	013001050	30,232
10,75	94	142	1	013001075	32,333
11	94	142	1	013001100	32,333
11,25	94	142	1	013001125	33,027
11,5	94	142	1	013001150	33,027
11,75	94	142	1	013001175	34,600
12	101	151	1	013001200	34,600
12,25	101	151	1	013001225	37,105
12,5	101	151	1	013001250	37,105
12,75	101	151	1	013001275	39,351
13	101	151	1	013001300	39,351

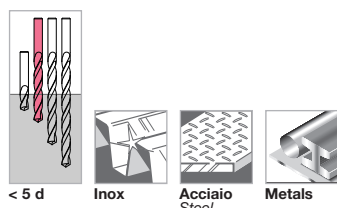

**Velocità di taglio consigliata / Recommended cutting speed**  
**Acciaio / Steel - 16 m/min**  
**Inox - 9 m/min**



19 pcs - Ø 1÷10 x 0,5 mm

**01310301 € 225,009**

25 pcs - Ø 1÷13 x 0,5 mm

**01310302 € 408,597**

Taglio a secco, ad alta velocità di rotazione ed avanzamento su tutti gli acciai duri e di difficile lavorabilità (acciai alto legati in genere, acciai inox) e materiali fortemente abrasivi (ghisa, leghe Al-Si). H.S.C. in high alloy steel, stainless steel, abrasive metals as cast iron, Al-Si Alloys. / Les outils revêtues en TiAlN favorisent le coupe de l'acier allié, acier inox, métal abrasif (Alliage Al-Si) avec paramètre de coupe augmentées de 40%. / El recubrimiento TiAlN permite aumentar la velocidad de corte y reducir desgastes de utensilios.

# 01150

## Punte elicoidali al cobalto 5% codolo conico Morse

Cobalt morse taper shank twist drills / Forets à queue conique morse au cobalt  
Brocas helicoidales de cobalto con mango conico / Cobalt Spiralbohrer mit Morsekegel

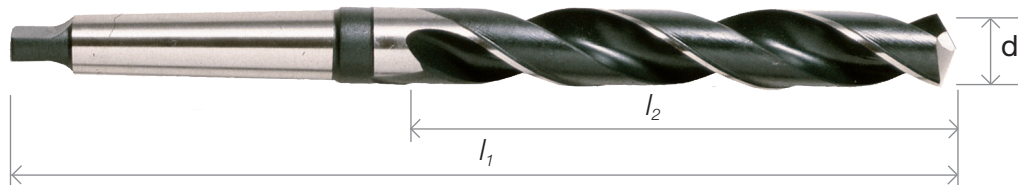

d	M.K.	$l_2$	$l_1$		cod.	€ cad/each
h8						
7	1	69	150	1	011500700	45,230
7,5	1	69	150	1	011500750	45,230
8	1	75	156	1	011500800	45,230
8,5	1	75	156	1	011500850	45,230
9	1	81	162	1	011500900	45,230
9,5	1	81	162	1	011500950	45,230
10	1	87	168	1	011501000	45,230
10,5	1	87	168	1	011501050	45,230
11	1	94	175	1	011501100	45,230
11,5	1	94	175	1	011501150	45,230
12	1	101	182	1	011501200	45,230
12,5	1	101	182	1	011501250	47,817
13	1	101	182	1	011501300	47,817
13,5	1	108	189	1	011501350	52,268
14	1	108	189	1	011501400	55,890
14,5	2	114	212	1	011501450	65,702
15	2	114	212	1	011501500	66,426
15,5	2	114	212	1	011501550	72,264
16	2	120	218	1	011501600	72,264
16,5	2	125	223	1	011501650	77,418
17	2	125	223	1	011501700	77,418
17,5	2	130	228	1	011501750	80,264
18	2	130	228	1	011501800	80,264
18,5	2	135	233	1	011501850	85,346
19	2	135	233	1	011501900	85,346
19,5	2	140	238	1	011501950	99,246
20	2	140	238	1	011502000	99,246
20,5	2	145	243	1	011502050	119,025
21	2	145	243	1	011502100	122,234
21,5	2	150	248	1	011502150	133,639

d	M.K.	$l_2$	$l_1$		cod.	€ cad/each
h8						
22	2	150	248	1	011502200	133,639
22,5	2	155	253	1	011502250	141,039
23	2	155	253	1	011502300	153,459
23,5	3	155	276	1	011502350	155,943
24	3	160	281	1	011502400	170,775
24,5	3	160	281	1	011502450	175,712
25	3	160	281	1	011502500	175,712
25,5	3	165	286	1	011502550	198,006
26	3	165	286	1	011502600	200,490
26,5	3	165	286	1	011502650	202,922
27	3	170	291	1	011502700	215,311
27,5	3	170	291	1	011502750	222,722
28	3	170	291	1	011502800	222,722
28,5	3	175	296	1	011502850	238,278
29	3	175	296	1	011502900	242,521
29,5	3	175	296	1	011502950	242,521
30	3	175	296	1	011503000	254,879
30,5	3	180	301	1	011503050	301,941
31	3	180	301	1	011503100	301,941
31,5	3	180	301	1	011503150	324,638
32	4	185	334	1	011503200	324,638
33	4	185	334	1	011503300	340,318
34	4	190	339	1	011503400	369,423
35	4	190	339	1	011503500	382,857
36	4	195	344	1	011503600	429,867
37	4	195	344	1	011503700	457,853
38	4	200	349	1	011503800	492,557
39	4	200	349	1	011503900	578,762
40	4	200	349	1	011504000	578,762

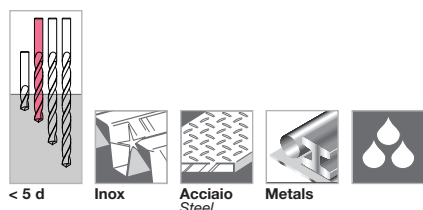

**Velocità di taglio consigliata / Recommended cutting speed**  
**Acciaio / Steel - 12 m/min**  
**Inox - 6 m/min**

Punte con ottima resistenza alle sollecitazioni termiche, adatte per forare acciai legati e non con R sino a 1200 N/mm<sup>2</sup>, in modo particolare acciai da bonifica, acciai per lavorazioni a caldo e a freddo, acciai inossidabili, ghisa etc. High performance in cutting alloy steel, cast iron, stainless steel and metals up to R ≤ 1200 N/mm<sup>2</sup>. / Pour percer l'acier allié, la fonte, l'acier inox avec R ≤ 1200 N/mm<sup>2</sup>. / Para taladar acero aleado, acero inox, fundicion R ≤ 1200 N/mm<sup>2</sup>. / Einsatz in legierte Stahl bis R ≤ 1200 N/mm<sup>2</sup> Zug-Festigkeit, Korrosionsbeständige Stähle, Grauguss und Stahlguss.

## 01140

**Punte elicoidali con affilatura a croce ed elica ad alta resistenza per forature profonde, serie corta.** Twist drills cross cut sharpened and special "high resistance flute design" for deep in to cutting, short serie / Forets helicoidaux, affutage croix et spiral rapide pour perçages profonds / Brocas helicoidales corte forma cruz, helice rapida para perforaciones profundas

HSS  
CO5

DIN  
338



DIN 1412/C Parabolic

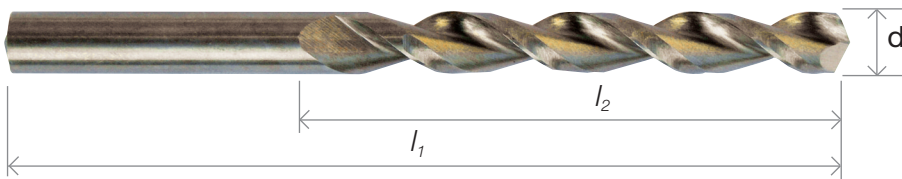

d h8	l <sub>2</sub>	l <sub>1</sub>		cod.	€ cad/each
2	24	49	10	011400200	2,805
2,25	27	53	10	011400225	2,805
2,5	30	57	10	011400250	2,805
2,75	33	61	10	011400275	2,991
3	33	61	10	011400300	2,991
3,2	36	65	10	011400320	3,333
3,25	36	65	10	011400325	3,333
3,5	39	70	10	011400350	3,333
3,75	39	70	10	011400375	3,674
4	43	75	10	011400400	3,674
4,2	43	75	10	011400420	4,430
4,25	43	75	10	011400425	4,430
4,5	47	80	10	011400450	4,430
4,75	47	80	10	011400475	4,844
4,8	52	86	10	011400480	4,844
5	52	86	10	011400500	4,844
5,2	52	86	10	011400520	5,724
5,25	52	86	10	011400525	5,724
5,5	57	93	10	011400550	5,724

d h8	l <sub>2</sub>	l <sub>1</sub>		cod.	€ cad/each
5,75	57	93	10	011400575	6,334
6	57	93	10	011400600	6,334
6,25	63	101	10	011400625	8,218
6,5	63	101	10	011400650	8,218
6,75	63	101	10	011400675	9,522
7	69	109	10	011400700	9,522
7,5	69	109	5	011400750	10,733
8	75	117	5	011400800	11,809
8,5	75	117	5	011400850	14,531
9	81	125	5	011400900	15,732
9,5	81	125	5	011400950	17,740
10	87	133	5	011401000	19,737
10,5	87	133	5	011401050	23,112
11	94	142	5	011401100	25,575
11,5	94	142	5	011401150	29,715
12	101	151	5	011401200	29,715
12,5	101	151	5	011401250	35,552
13	101	151	5	011401300	38,813

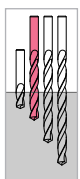

≤ 5 d



Inox



Acciaio  
Steel



Metals



**Velocità di taglio consigliata / Recommended cutting speed**  
**Acciaio / Steel - 12 m/min**  
**Inox - 6 m/min**



Abs

Punte con ottima resistenza alle sollecitazioni termiche, adatte per forare acciai legati e non con R sino a 1200 N/mm<sup>2</sup>, in modo particolare acciai da bonifica, acciai per lavorazioni a caldo e a freddo, acciai inossidabili, ghisa etc. High performance in cutting alloy steel, cast iron, stainless steel and metals up to R ≤ 1200 N/mm<sup>2</sup>. / Pour percer l'acier allié, la fonte, l'acier inox avec R ≤ 1200 N/mm<sup>2</sup>. / Para taladar acero aleado, acero inox, fundicion R ≤ 1200 N/mm<sup>2</sup>. / Einsatz in legierte Stahl bis R ≤ 1200 N/mm<sup>2</sup> Zug-Festigkeit, Korrosionsbeständige Stähle, Grauguss und Stahlguss.

19 pcs - Ø 1÷10 x 0,5 mm\*

01142401 € 163,530

25 pcs - Ø 1÷13 x 0,5 mm\*

01142402 € 347,760

\*Ø 1mm, 1,5 mm Art. 01145

# 01305

**Punte elicoidali con affilatura a croce ed elica ad alta resistenza per forature profonde, serie corta.** Twist drills cross cut sharpened and special "high resistance flute design" for deep in to cutting, short serie / Forets helicoidaux, affutage croix et spiral rapide pour perçages profonds / Brocas helicoidales corte forma cruz, helice rapida para perforaciones profundas

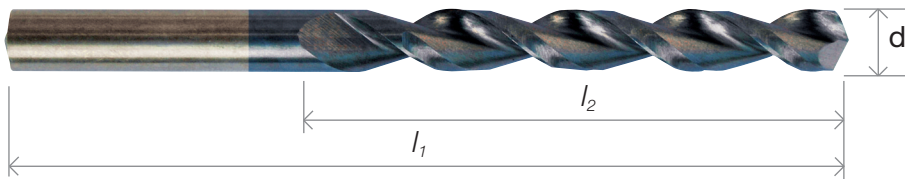
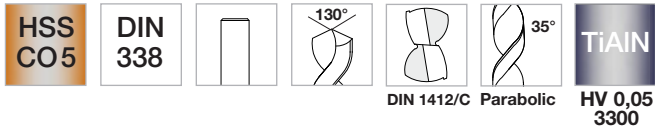

d h8	$l_2$	$l_1$		cod.	€ cad/each
2	24	49	10	013050200	10,164
2,25	27	53	10	013050225	10,164
2,5	30	57	10	013050250	10,164
2,75	33	61	10	013050275	10,360
3	33	61	10	013050300	10,360
3,2	36	65	10	013050320	10,692
3,25	36	65	10	013050325	10,692
3,5	39	70	10	013050350	10,692
3,75	39	70	10	013050375	11,023
4	43	75	10	013050400	11,023
4,2	43	75	10	013050420	13,072
4,25	43	75	10	013050425	13,072
4,5	47	80	10	013050450	13,072
4,75	47	80	10	013050475	13,465
4,8	52	86	10	013050480	13,465
5	52	86	10	013050500	13,465
5,2	52	86	10	013050520	14,335
5,25	52	86	10	013050525	14,335
5,5	57	93	10	013050550	14,335

d h8	$l_2$	$l_1$		cod.	€ cad/each
5,75	57	93	10	013050575	14,914
6	57	93	10	013050600	14,914
6,25	63	101	10	013050625	19,644
6,5	63	101	10	013050650	19,644
6,75	63	101	10	013050675	20,907
7	69	109	10	013050700	20,907
7,5	69	109	5	013050750	22,087
8	75	117	5	013050800	23,122
8,5	75	117	5	013050850	25,761
9	81	125	5	013050900	29,663
9,5	81	125	5	013050950	31,609
10	87	133	5	013051000	33,555
10,5	87	133	5	013051050	39,299
11	94	142	5	013051100	41,690
11,5	94	142	5	013051150	45,706
12	101	151	5	013051200	45,706
12,5	101	151	5	013051250	53,271
13	101	151	5	013051300	56,428

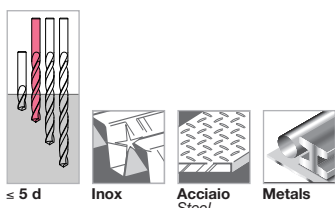

**Velocità di taglio consigliata / Recommended cutting speed**  
**Acciaio / Steel - 16 m/min**  
**Inox - 9 m/min**



19 pcs -  $\varnothing$  1÷10 x 0,5 mm\*  
**01310305 € 287,585**  
 25 pcs -  $\varnothing$  1÷13 x 0,5 mm\*  
**01310306 € 522,841**

Punte con ottima resistenza alle sollecitazioni termiche, adatte per forare acciai legati e non con R sino a 1200 N/mm<sup>2</sup>, in modo particolare acciai da bonifica, acciai per lavorazioni a caldo e a freddo, acciai inossidabili, ghisa etc. High performance in cutting alloy steel, cast iron, stainless steel and metals up to R  $\leq$  1200 N/mm<sup>2</sup>. / Pour percer l'acier allié, la fonte, l'acier inox avec R  $\leq$  1200 N/mm<sup>2</sup>. / Para taladar acero aleado, acero inox, fundicion R  $\leq$  1200 N/mm<sup>2</sup>. / Einsatz in legierte Stahl bis R  $\leq$  1200 N/mm<sup>2</sup> Zug-Festigkeit, Korrosionsbeständige Stähle, Grauguss und Stahlguss.

## 01141

Punte elicoidali con affilatura a croce ed elica ad alta resistenza per forature profonde. Twist drills cross cut sharpened and special "high resistance flute design" for deep in to cutting. / Forets helicoidaux, affutage croix et spiral rapide pour perçages profonds. / Brocas helicoidales corte forma cruz, helice rapida para perforaciones profundas

HSS  
CO5

DIN  
340



DIN 1412/C Parabolic

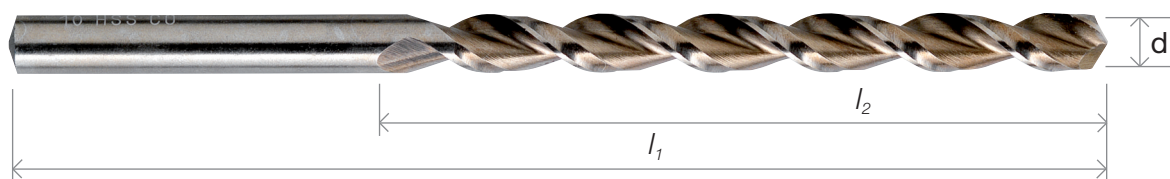

d	l <sub>2</sub>	l <sub>1</sub>		cod.	€ cad/each
h8					
2,5	62	95	10	011410250	5,020
3	66	100	10	011410300	5,372
3,25	69	106	10	011410325	6,345
3,5	73	112	10	011410350	6,345
3,75	73	112	10	011410375	6,945
4	78	119	10	011410400	6,945
4,25	78	119	10	011410425	8,301
4,5	82	126	10	011410450	8,301
4,75	82	126	10	011410475	8,808
5	87	132	10	011410500	8,808
5,25	87	132	10	011410525	10,629
5,5	91	139	10	011410550	10,629
5,75	91	139	10	011410575	10,629
6	91	139	10	011410600	10,629
6,25	97	148	5	011410625	15,680

d	l <sub>2</sub>	l <sub>1</sub>		cod.	€ cad/each
h8					
6,5	97	148	5	011410650	15,680
7	102	156	5	011410700	18,237
7,5	102	156	5	011410750	19,686
8	109	165	5	011410800	21,818
8,5	109	165	5	011410850	23,950
9	115	175	5	011410900	25,678
9,5	115	175	5	011410950	26,082
10	121	184	5	011411000	28,080
10,5	121	184	5	011411050	38,740
11	128	195	5	011411100	42,321
11,5	128	195	5	011411150	43,180
12	134	205	5	011411200	47,527
12,5	134	205	5	011411250	48,987
13	134	205	5	011411300	51,284

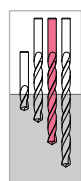

≤ 8 d



Inox



Acciaio  
Steel



Metals

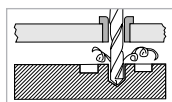

Velocità di taglio consigliata / Recommended cutting speed  
Acciaio / Steel - 12 m/min  
Inox - 6 m/min

Punte con ottima resistenza alle sollecitazioni termiche, adatte per forare acciai legati e non con R sino a 1200 N/mm<sup>2</sup>, in modo particolare acciai da bonifica, acciai per lavorazioni a caldo e a freddo, acciai inossidabili, ghisa etc. High performance in cutting alloy steel, cast iron, stainless steel and metals up to R ≤ 1200 N/mm<sup>2</sup>. / Pour percer l'acier allié, la fonte, l'acier inox avec R ≤ 1200 N/mm<sup>2</sup>. / Para taladar acero aleado, acero inox, fundicion R ≤ 1200 N/mm<sup>2</sup>. / Einsatz in legierte Stahl bis R ≤ 1200 N/mm<sup>2</sup> Zug-Festigkeit, Korrosionsbeständige Stähle, Grauguss und Stahlguss.

# 01306

Punte elicoidali con affilatura a croce ed elica ad alta resistenza per forature profonde. Twist drills cross cut sharpened and special "high resistance flute design" for deep in to cutting / Forets helicoidaux, affutage croix et spiral rapide pour perçages profonds / Brocas helicoidales corte forma cruz, helice rapida para perforaciones profundas

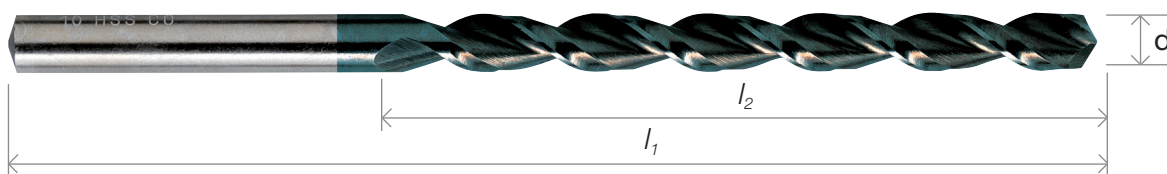
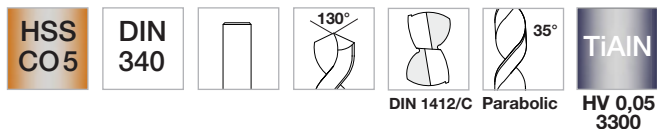

d	$l_2$	$l_1$		cod.	€ cad/each
h8					
2,5	62	95	10	013060250	12,285
3	66	100	10	013060300	12,627
3,25	69	106	10	013060325	13,559
3,5	73	112	10	013060350	13,559
3,75	73	112	10	013060375	14,148
4	78	119	10	013060400	14,148
4,25	78	119	10	013060425	16,777
4,5	82	126	10	013060450	16,777
4,75	82	126	10	013060475	17,264
5	87	132	10	013060500	17,264
5,25	87	132	10	013060525	19,023
5,5	91	139	10	013060550	19,023
5,75	91	139	10	013060575	19,023
6	91	139	10	013060600	19,023
6,25	97	148	5	013060625	26,786

d	$l_2$	$l_1$		cod.	€ cad/each
h8					
6,5	97	148	5	013060650	26,786
7	102	156	5	013060700	29,249
7,5	102	156	5	013060750	30,657
8	109	165	5	013060800	33,782
8,5	109	165	5	013060850	37,488
9	115	175	5	013060900	39,154
9,5	115	175	5	013060950	39,547
10	121	184	5	013061000	43,542
10,5	121	184	5	013061050	54,234
11	128	195	5	013061100	57,681
11,5	128	195	5	013061150	58,519
12	134	205	5	013061200	67,006
12,5	134	205	5	013061250	70,732
13	134	205	5	013061300	72,947

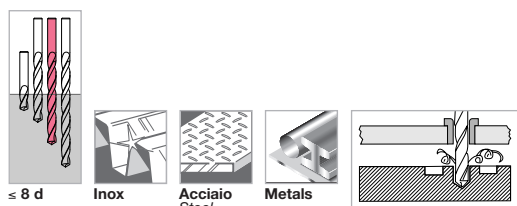

Velocità di taglio consigliata / Recommended cutting speed  
 Acciaio / Steel - 16 m/min  
 Inox - 9 m/min

Punte con ottima resistenza alle sollecitazioni termiche, adatte per forare acciai legati e non con R sino a 1200 N/mm<sup>2</sup>, in modo particolare acciai da bonifica, acciai per lavorazioni a caldo e a freddo, acciai inossidabili, ghisa etc. High performance in cutting alloy steel, cast iron, stainless steel and metals up to R ≤ 1200 N/mm<sup>2</sup>. / Pour percer l'acier allié, la fonte, l'acier inox avec R ≤ 1200 N/mm<sup>2</sup>. / Para taladar acero aleado, acero inox, fundicion R ≤ 1200 N/mm<sup>2</sup>. / Einsatz in legierte Stahl bis R ≤ 1200 N/mm<sup>2</sup> Zug-Festigkeit, Korrosionsbeständige Stähle, Grauguss und Stahlguss.

## 01143

Punte elicoidali con affilatura a croce ed elica ad alta resistenza, serie extra corta.  
Extra short twist drills cross cut sharpened and special "high resistance flute design".

Forets helicoidaux, affutage croix et spiral rapide / Brocas helicoidales corte forma cruz, helice rapida.

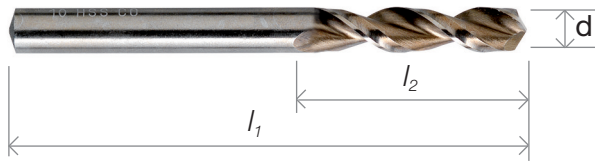
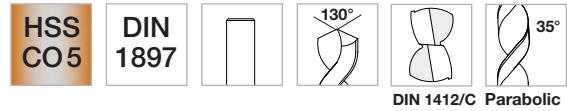

d h8	l <sub>2</sub>	l <sub>1</sub>		cod.	€ cad/each	d h8	l <sub>2</sub>	l <sub>1</sub>		cod.	€ cad/each
3	16	46	10	011430300	1,904	5,7	28	66	10	011430570	5,589
3,2	18	49	10	011430320	1,946	5,75	28	66	10	011430575	5,589
3,25	18	49	10	011430325	1,946	5,8	28	66	10	011430580	5,589
3,3	18	49	10	011430330	1,946	6	28	66	10	011430600	3,923
3,5	20	52	10	011430350	2,039	6,5	31	70	10	011430650	5,123
3,7	20	52	10	011430370	2,277	7	24	74	10	011430700	6,324
3,75	20	52	10	011430375	2,277	7,5	34	74	5	011430750	6,748
3,8	22	55	10	011430380	2,277	8	37	79	5	011430800	7,380
4	22	55	10	011430400	2,277	8,5	37	79	5	011430850	10,278
4,2	22	55	10	011430420	2,277	9	40	84	5	011430900	10,278
4,25	22	55	10	011430425	2,277	9,5	40	84	5	011430950	15,318
4,5	24	58	10	011430450	2,567	10	43	89	5	011431000	15,318
4,7	24	58	10	011430470	3,012	10,5	43	89	5	011431050	19,986
4,75	24	58	10	011430475	3,012	11	47	95	5	011431100	21,300
4,8	26	62	10	011430480	3,012	11,5	47	95	5	011431150	22,739
5	26	62	10	011430500	3,012	12	51	102	5	011431200	25,440
5,2	26	62	10	011430520	4,068	12,5	51	102	5	011431250	25,979
5,25	26	62	10	011430525	4,068	13	51	102	5	011431300	25,979
5,5	28	66	10	011430550	3,695						

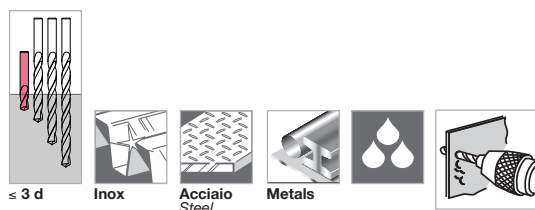

Velocità di taglio consigliata / Recommended cutting speed  
Acciaio / Steel - 12 m/min  
Inox - 6 m/min

Punte con ottima resistenza alle sollecitazioni termiche, adatte per forare acciai legati e non con R sino a 1200 N/mm<sup>2</sup>, in modo particolare acciai da bonifica, acciai per lavorazioni a caldo e a freddo, acciai inossidabili, ghisa etc. High performance in cutting alloy steel, cast iron, stainless steel and metals up to R ≤ 1200 N/mm<sup>2</sup>. / Pour percer l'acier allié, la fonte, l'acier inox avec R ≤ 1200 N/mm<sup>2</sup>. / Para taladar acero aleado, acero inox, fundicion R ≤ 1200 N/mm<sup>2</sup>. / Einsatz in legierte Stahl bis R ≤ 1200 N/mm<sup>2</sup> Zug-Festigkeit, Korrosionsbeständige Stähle, Grauguss und Stahlguss.

# 01307

Punte elicoidali con affilatura a croce ed elica ad alta resistenza, serie extra corta.

Extra short twist drills cross cut sharpened and special "high resistance flute design".

Forets helicoidaux, affutage croix et spiral rapide / Brocas helicoidales corte forma cruz, helice rapida.

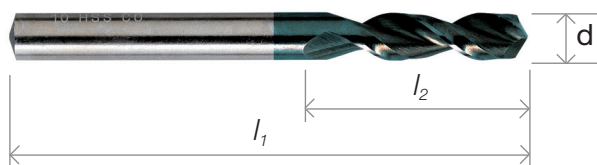
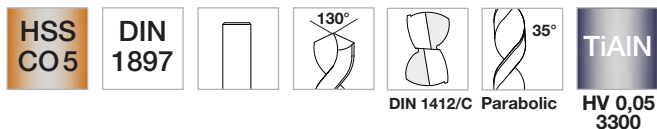

d h8	$l_2$	$l_1$		cod.	€ cad/each
3	16	46	10	013070300	9,294
3,2	18	49	10	013070320	9,336
3,25	18	49	10	013070325	9,336
3,3	18	49	10	013070330	9,336
3,5	20	52	10	013070350	9,419
3,7	20	52	10	013070370	9,646
3,75	20	52	10	013070375	9,646
3,8	22	55	10	013070380	9,646
4	22	55	10	013070400	9,646
4,2	22	55	10	013070420	10,971
4,25	22	55	10	013070425	10,971
4,5	24	58	10	013070450	11,250
4,7	24	58	10	013070470	11,685
4,75	24	58	10	013070475	11,685
4,8	26	62	10	013070480	11,685
5	26	62	10	013070500	11,685
5,2	26	62	10	013070520	12,699
5,25	26	62	10	013070525	12,699
5,5	28	66	10	013070550	12,337

d h8	$l_2$	$l_1$		cod.	€ cad/each
5,7	28	66	10	013070570	14,159
5,75	28	66	10	013070575	14,159
5,8	28	66	10	013070580	14,159
6	28	66	10	013070600	12,565
6,5	31	70	10	013070650	16,612
7	24	74	10	013070700	17,771
7,5	34	74	5	013070750	18,175
8	37	79	5	013070800	18,785
8,5	37	79	5	013070850	24,312
9	40	84	5	013070900	24,312
9,5	40	84	5	013070950	29,166
10	43	89	5	013071000	29,166
10,5	43	89	5	013071050	36,163
11	47	95	5	013071100	37,426
11,5	47	95	5	013071150	38,813
12	51	102	5	013071200	41,421
12,5	51	102	5	013071250	43,832
13	51	102	5	013071300	43,832

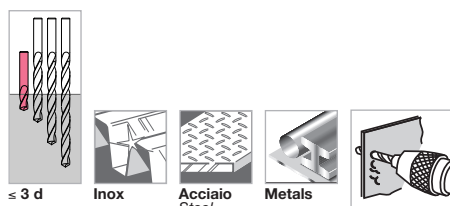

Velocità di taglio consigliata / Recommended cutting speed  
 Acciaio / Steel - 16 m/min  
 Inox - 9 m/min

Punte con ottima resistenza alle sollecitazioni termiche, adatte per forare acciai legati e non con R sino a 1200 N/mm<sup>2</sup>, in modo particolare acciai da bonifica, acciai per lavorazioni a caldo e a freddo, acciai inossidabili, ghisa etc. High performance in cutting alloy steel, cast iron, stainless steel and metals up to R ≤ 1200 N/mm<sup>2</sup>. / Pour percer l'acier allié, la fonte, l'acier inox avec R ≤ 1200 N/mm<sup>2</sup>. / Para taladar acero aleado, acero inox, fundicion R ≤ 1200 N/mm<sup>2</sup>. / Einsatz in legierte Stahl bis R ≤ 1200 N/mm<sup>2</sup> Zug-Festigkeit, Korrosionsbeständige Stähle, Grauguss und Stahlguss.



## 01120

### Punte elicoidali al cobalto 8%, esecuzione interamente rettificata, serie corta

Cobalt twist drills ground from the solid / Forets cylindriques au cobalt entièrement rectifiés

Broca helicoidal rectificada de cobalto / Kobalt Spiralbohrer

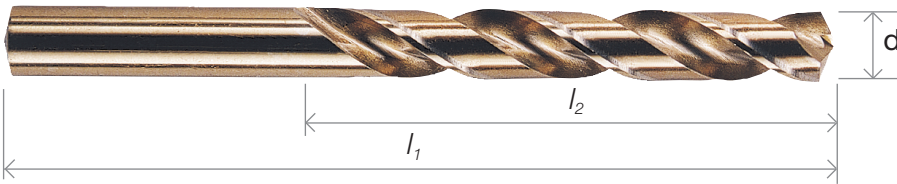
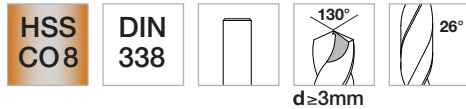

d	l <sub>2</sub>	l <sub>1</sub>		cod.	€ cad/each	d	l <sub>2</sub>	l <sub>1</sub>		cod.	€ cad/each
<b>h8</b>						<b>h8</b>					
0,3	3	19	10	011200030	5,123	2,3	27	53	10	011200230	2,236
0,35	4	19	10	011200035	5,123	2,4	30	57	10	011200240	2,236
0,4	5	20	10	011200040	5,123	<b>2,5</b>	30	57	10	011200250	2,039
0,45	5	20	10	011200045	5,123	2,6	30	57	10	011200260	2,236
<b>0,5</b>	6	22	10	011200050	3,933	2,7	33	61	10	011200270	2,236
0,55	7	24	10	011200055	3,933	<b>2,75</b>	33	61	10	011200275	2,236
0,6	7	24	10	011200060	3,933	2,8	33	61	10	011200280	2,236
0,65	8	26	10	011200065	3,933	2,9	33	61	10	011200290	2,236
0,7	9	28	10	011200070	3,933	<b>3</b>	33	61	10	011200300	2,039
<b>0,75</b>	9	28	10	011200075	3,933	3,1	36	65	10	011200310	2,846
0,8	10	30	10	011200080	3,933	3,2	36	65	10	011200320	2,846
0,85	10	30	10	011200085	3,933	<b>3,25</b>	36	65	10	011200325	2,846
0,9	11	32	10	011200090	3,933	3,3	36	65	10	011200330	2,846
0,95	11	32	10	011200095	3,933	3,4	39	70	10	011200340	2,846
<b>1</b>	12	34	10	011200100	1,925	<b>3,5</b>	39	70	10	011200350	2,588
1,1	14	36	10	011200110	2,122	3,6	39	70	10	011200360	3,126
1,2	16	38	10	011200120	2,122	3,7	39	70	10	011200370	3,126
<b>1,25</b>	16	38	10	011200125	2,122	<b>3,75</b>	39	70	10	011200375	3,126
1,3	16	38	10	011200130	2,122	3,8	43	75	10	011200380	3,126
1,4	18	40	10	011200140	2,122	3,9	43	75	10	011200390	3,126
<b>1,5</b>	18	40	10	011200150	1,925	<b>4</b>	43	75	10	011200400	2,846
1,6	20	43	10	011200160	2,122	4,1	43	75	10	011200410	3,581
1,7	20	43	10	011200170	2,122	4,2	43	75	10	011200420	3,581
<b>1,75</b>	22	46	10	011200175	2,122	<b>4,25</b>	43	75	10	011200425	3,581
1,8	22	46	10	011200180	2,122	4,3	47	80	10	011200430	3,581
1,9	22	46	10	011200190	2,122	4,4	47	80	10	011200440	3,581
<b>2</b>	24	49	10	011200200	1,925	<b>4,5</b>	47	80	10	011200450	3,260
2,1	24	49	10	011200210	2,236	4,6	47	80	10	011200460	3,809
2,2	27	53	10	011200220	2,236	4,7	47	80	10	011200470	3,809
<b>2,25</b>	27	53	10	011200225	2,236	<b>4,75</b>	47	80	10	011200475	3,809

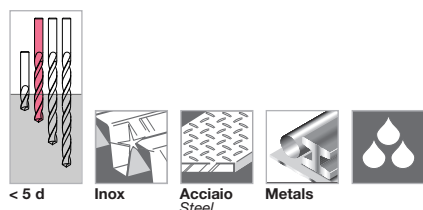



**Velocità di taglio consigliata / Recommended cutting speed**  
**Acciaio / Steel - 15 m/min**  
**Inox - 8 m/min**



L'alta percentuale di Cobalto(e Molibdeno) rende questa punta particolarmente resistente alle sollecitazioni meccaniche e termiche e, pertanto, è adatta alle lavorazioni dell'acciaio inox e degli acciai resistenti al calore, di tutti gli acciai alto legati e delle leghe molto tenaci (Acciai al Ni Cr, hastelloy, nimonin, inconel). High performances in cutting stainless steel, alloy steel up to R ≤ 1400 N/mm<sup>2</sup>. / Pour percer l'acier inox et l'acier allié avec R ≤ 1400 N/mm<sup>2</sup>. Para taladar acero inox R ≤ 1400 N/mm<sup>2</sup>. / Einsatz: Geeignet für legierte Stähle bis R ≤ 1400 N/mm<sup>2</sup> Zug-Festigkeit Korrosionsbeständige Stähle (V 2A - V 4A etc.), Säure und Hitzebeständige, Grauguss und Stahlguss.

19 pcs - Ø 1÷10 x 0,5 mm  
**01135301 € 100,747**  
 25 pcs - Ø 1÷13 x 0,5 mm  
**01135302 € 221,656**

d h8	$l_2$	$l_1$		cod.	€ cad/each
4,8	52	86	10	011200480	3,809
4,9	52	86	10	011200490	3,809
<b>5</b>	52	86	10	011200500	3,457
5,1	52	86	10	011200510	5,154
5,2	52	86	10	011200520	5,154
<b>5,25</b>	52	86	10	011200525	5,154
5,3	52	86	10	011200530	5,154
5,4	57	93	10	011200540	5,154
<b>5,5</b>	57	93	10	011200550	4,678
5,6	57	93	10	011200560	5,372
5,7	57	93	10	011200570	5,372
<b>5,75</b>	57	93	10	011200575	5,372
5,8	57	93	10	011200580	5,372
5,9	57	93	10	011200590	5,372
<b>6</b>	57	93	10	011200600	4,885
6,1	63	101	10	011200610	6,810
6,2	63	101	10	011200620	6,810
<b>6,25</b>	63	101	10	011200625	6,810
6,3	63	101	10	011200630	6,810
6,4	63	101	10	011200640	6,810
<b>6,5</b>	63	101	10	011200650	6,469
6,6	63	101	10	011200660	7,990
6,7	63	101	10	011200670	7,990
<b>6,75</b>	69	109	10	011200675	7,990
6,8	69	109	10	011200680	7,990
6,9	69	109	10	011200690	7,990
<b>7</b>	69	109	10	011200700	7,452
7,1	69	109	5	011200710	9,729
7,2	69	109	5	011200720	9,729
<b>7,25</b>	69	109	5	011200725	9,729
7,3	69	109	5	011200730	9,729
7,4	69	109	5	011200740	9,729
<b>7,5</b>	69	109	5	011200750	8,280
7,6	75	117	5	011200760	10,557
7,7	75	117	5	011200770	10,557
<b>7,75</b>	75	117	5	011200775	10,557
7,8	75	117	5	011200780	10,557
7,9	75	117	5	011200790	10,557
<b>8</b>	75	117	5	011200800	9,626
8,1	75	117	5	011200810	11,592
8,2	75	117	5	011200820	11,592
<b>8,25</b>	75	117	5	011200825	11,592
8,3	75	117	5	011200830	11,592
8,4	75	117	5	011200840	11,592
<b>8,5</b>	75	117	5	011200850	10,661
8,6	81	125	5	011200860	13,559
8,7	81	125	5	011200870	13,559
<b>8,75</b>	81	125	5	011200875	13,559
8,8	81	125	5	011200880	13,559
8,9	81	125	5	011200890	13,559
<b>9</b>	81	125	5	011200900	12,834
9,1	81	125	5	011200910	15,784
9,2	81	125	5	011200920	15,784
<b>9,25</b>	81	125	5	011200925	15,784
9,3	81	125	5	011200930	15,784
9,4	81	125	5	011200940	15,784
<b>9,5</b>	81	125	5	011200950	13,662
9,6	87	133	5	011200960	16,508
9,7	87	133	5	011200970	16,508
<b>9,75</b>	87	133	5	011200975	16,508

d h8	$l_2$	$l_1$		cod.	€ cad/each
9,8	87	133	5	011200980	16,508
9,9	87	133	5	011200990	16,508
<b>10</b>	87	133	5	011201000	15,877
10,1	87	133	5	011201010	19,334
10,2	87	133	5	011201020	19,334
<b>10,25</b>	87	133	5	011201025	19,334
10,3	87	133	5	011201030	19,334
10,4	87	133	5	011201040	19,334
<b>10,5</b>	87	133	5	011201050	18,527
10,6	87	133	5	011201060	22,387
10,7	94	142	5	011201070	22,387
<b>10,75</b>	94	142	5	011201075	22,387
10,8	94	142	5	011201080	22,387
10,9	94	142	5	011201090	22,387
<b>11</b>	94	142	5	011201100	21,373
11,1	94	142	5	011201110	24,323
11,2	94	142	5	011201120	24,323
<b>11,25</b>	94	142	5	011201125	24,323
11,3	94	142	5	011201130	24,323
11,4	94	142	5	011201140	24,323
<b>11,5</b>	94	142	5	011201150	22,667
11,6	94	142	5	011201160	25,409
11,7	94	142	5	011201170	25,409
<b>11,75</b>	94	142	5	011201175	25,409
11,8	94	142	5	011201180	25,409
11,9	101	151	5	011201190	25,409
<b>12</b>	101	151	5	011201200	24,685
12,1	101	151	5	011201210	28,256
12,2	101	151	5	011201220	28,256
<b>12,25</b>	101	151	5	011201225	28,256
12,3	101	151	5	011201230	28,256
12,4	101	151	5	011201240	28,256
<b>12,5</b>	101	151	5	011201250	26,703
12,6	101	151	5	011201260	30,077
12,7	101	151	5	011201270	30,077
<b>12,75</b>	101	151	5	011201275	30,077
12,8	101	151	5	011201280	30,077
12,9	101	151	5	011201290	30,077
<b>13</b>	101	151	5	011201300	28,773
13,25	108	160	3	011201325	43,522
13,5	108	160	3	011201350	43,522
13,75	108	160	3	011201375	43,522
<b>14</b>	108	160	3	011201400	43,522
14,25	114	169	3	011201425	59,554
14,5	114	169	3	011201450	59,554
14,75	114	169	3	011201475	59,554
<b>15</b>	114	169	3	011201500	59,554
15,25	120	178	3	011201525	63,788
15,5	120	178	3	011201550	63,788
15,75	120	178	3	011201575	63,788
<b>16</b>	120	178	3	011201600	63,788
16,5	125	184	1	011201650	77,625
<b>17</b>	125	184	1	011201700	77,625
17,5	130	191	1	011201750	87,975
<b>18</b>	130	191	1	011201800	87,975
18,5	135	198	1	011201850	98,325
<b>19</b>	135	198	1	011201900	98,325
19,5	140	205	1	011201950	111,780
<b>20</b>	140	205	1	011202000	111,780

## 01135

### Assortimenti punte al cobalto 8% in scatole di metallo

Sets of cobalt twist drills / Assortiments forets au cobalt

Juego brocas de cobalto / Kobalt-geschliffene Spiralbohrersätze

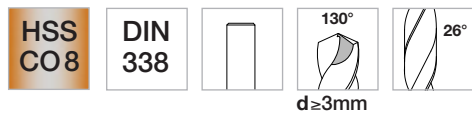

**Metal**

49 pcs - Ø 1÷13 x 0,25 mm

01135412 € 536,223

37 pcs - Ø 1÷10 x 0,25 mm

01135411 € 240,679

51 pcs - Ø 1÷6 x 0,1 mm

01135403 € 183,588

41 pcs - Ø 6÷10 x 0,1 mm

01135404 € 553,011

91 pcs - Ø 1÷10 x 0,1 mm

01135406 € 952,655

91 pcs - Ø 1÷10 x 0,1 mm **Plastic box**

01135220 € 648,169

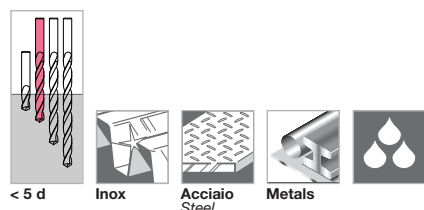

< 5 d

Inox

Acciaio  
Steel

Metals

**Velocità di taglio consigliata / Recommended cutting speed**

**Acciaio / Steel - 15 m/min**

**Inox - 8 m/min**



01135301

L'alta percentuale di Cobalto(e Molibdeno) rende questa punta particolarmente resistente alle sollecitazioni meccaniche e termiche e, pertanto, é adatta alle lavorazioni dell'acciaio inox e degli acciai resistenti al calore, di tutti gli acciai alto legati e delle leghe molto tenaci (Acciai al Ni Cr, hastelloy, nimonin, inconel). High performances in cutting stainless steel, alloy steel up to  $R \leq 1400 \text{ N/mm}^2$ . / Pour percer l'acier inox et l'acier allié avec  $R \leq 1400 \text{ N/mm}^2$ . Para taladar acero inox  $R \leq 1400 \text{ N/mm}^2$ . / Einsatz: Geeignet für legierte Stähle bis  $R \leq 1400 \text{ N/mm}^2$  Zug-Festigkeit Korrosionsbeständige Stähle (V 2A - V 4A etc.), Säure und Hitzebeständige, Grauguss und Stahlguss.

# 01135

## Assortimenti punte al cobalto 8% in scatole di metallo

Sets of cobalt twist drills / Assortiments forets au cobalt

Juego brocas de cobalto / Kobalt-geschliffene Spiralbohrersätze

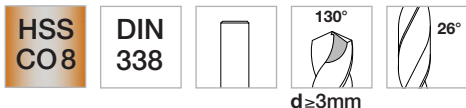

Metal

116 pcs - Ø 1÷10 x 0,5 mm  
Ø 1 ÷ 5 mm - 10 pcs  
Ø 5,5 ÷ 8 mm - 3 pcs  
Ø 8,5 ÷ 10 mm - 2 pcs

01135450 € 450,018

 331x228x48

128 pcs - Ø 1÷13 x 0,5 mm  
Ø 1 ÷ 5 mm - 10 pcs  
Ø 5,5 ÷ 8 mm - 3 pcs  
Ø 8,5 ÷ 13 mm - 2 pcs

01135451 € 782,501

 497x266x59

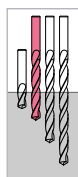

< 5 d



Inox



Acciaio  
Steel



Metals



Velocità di taglio consigliata / Recommended cutting speed

Acciaio / Steel - 15 m/min

Inox - 8 m/min

L'alta percentuale di Cobalto(e Molibdeno) rende questa punta particolarmente resistente alle sollecitazioni meccaniche e termiche e, pertanto, é adatta alle lavorazioni dell'acciaio inox e degli acciai resistenti al calore, di tutti gli acciai alto legati e delle leghe molto tenaci (Acciai al Ni Cr, hastelloy, nimonic, inconel). High performances in cutting stainless steel, alloy steel up to  $R \leq 1400 \text{ N/mm}^2$ . / Pour percer l'acier inox et l'acier allié avec  $R \leq 1400 \text{ N/mm}^2$ . Para taladar acero inox  $R \leq 1400 \text{ N/mm}^2$ . / Einsatz: Geeignet für legierte Stähle bis  $R \leq 1400 \text{ N/mm}^2$  Zug-Festigkeit Korrosionsbeständige Stähle (V 2A - V 4A etc.), Säure und Hitzebeständige, Grauguss und Stahlguss.

## 01122

### Punte elicoidali cilindriche al cobalto 8% con codolo ridotto

Cobalt reduced shank twist drills / Forets cylindriques à queue réduite au cobalt

Brocas helicoidales de cobalto con mango reducido / Kobalt-Spiralbohrer mit reduzierten Schaft

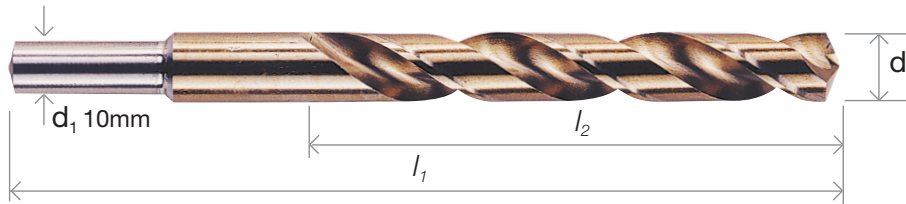
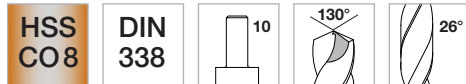

d	h8	l <sub>2</sub>	l <sub>1</sub>	d <sub>1</sub>		cod.	€ cad/each	d	h8	l <sub>2</sub>	l <sub>1</sub>	d <sub>1</sub>		cod.	€ cad/each
10,25		87	133	10	5	011221025	21,538	14,25		114	169	10	3	011221425	57,670
<b>10,5</b>		87	133	10	5	011221050	21,538	<b>14,5</b>		114	169	10	3	011221450	57,670
10,75		94	142	10	5	011221075	24,695	14,75		114	169	10	3	011221475	57,670
<b>11</b>		94	142	10	5	011221100	24,695	<b>15</b>		114	169	10	3	011221500	57,670
11,25		94	142	10	5	011221125	27,376	15,25		120	178	10	3	011221525	68,652
<b>11,5</b>		94	142	10	5	011221150	27,376	<b>15,5</b>		120	178	10	3	011221550	68,652
11,75		94	142	10	5	011221175	29,974	15,75		120	178	10	3	011221575	68,652
<b>12</b>		101	151	10	5	011221200	29,974	<b>16</b>		120	178	10	3	011221600	68,652
12,25		101	151	10	5	011221225	32,561	16,5		125	184	10	1	011221650	79,498
<b>12,5</b>		101	151	10	5	011221250	32,561	<b>17</b>		125	184	10	1	011221700	79,498
12,75		101	151	10	5	011221275	35,024	17,5		130	191	10	1	011221750	91,805
<b>13</b>		101	151	10	5	011221300	35,024	<b>18</b>		130	191	10	1	011221800	106,760
13,25		108	160	10	3	011221325	48,159	18,5		135	198	10	1	011221850	106,760
<b>13,5</b>		108	160	10	3	011221350	48,159	<b>19</b>		135	198	10	1	011221900	106,760
13,75		108	160	10	3	011221375	48,159	19,5		140	205	10	1	011221950	119,998
<b>14</b>		108	160	10	3	011221400	48,159	<b>20</b>		140	205	10	1	011222000	119,998

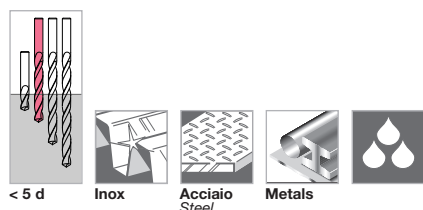

**Velocità di taglio consigliata / Recommended cutting speed**  
**Acciaio / Steel - 15 m/min**  
**Inox - 8 m/min**

L'alta percentuale di Cobalto(e Molibdeno) rende questa punta particolarmente resistente alle sollecitazioni meccaniche e termiche e, pertanto, é adatta alle lavorazioni dell'acciaio inox e degli acciai resistenti al calore, di tutti gli acciai alto legati e delle leghe molto tenaci (Acciai al Ni Cr, hastelloy, nimonic, inconel). High performances in cutting stainless steel, alloy steel up to R ≤ 1400 N/mm<sup>2</sup>. / Pour percer l'acier inox et l'acier allié avec R ≤ 1400 N/mm<sup>2</sup>. / Para taladar acero inox R ≤ 1400 N/mm<sup>2</sup>. / Einsatz: Geeignet für legierte Stähle bis R ≤ 1400 N/mm<sup>2</sup> Zug-Festigkeit Korrosionsbeständige Stähle (V 2A - V 4A etc.), Säure und Hitzebeständige, Grauguss und Stahlguss.

# 01123

## Punte elicoidali cilindriche al cobalto 8% con codolo ridotto

Cobalt reduced shank twist drills / Forets cylindriques à queue réduite au cobalt

Brocas helicoidales de cobalto con mango reducido / Kobalt-Spiralbohrer mit reduzierten Schaft

HSS  
CO8

DIN  
338

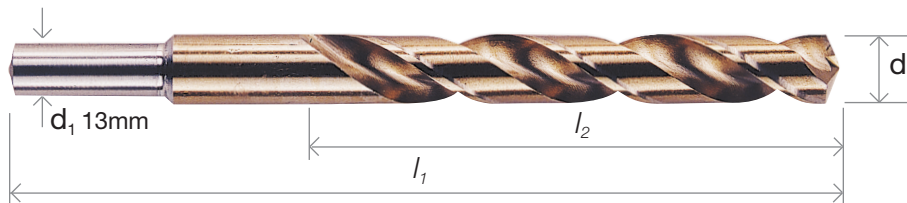

d	$l_2$	$l_1$	$d_1$		cod.	€ cad/each	d	$l_2$	$l_1$	$d_1$		cod.	€ cad/each
h8							h8						
13,25	108	160	13	3	011231325	48,159	15,75	120	178	13	3	011231575	68,652
<b>13,5</b>	108	160	13	3	011231350	48,159	<b>16</b>	120	178	13	3	011231600	68,652
13,75	108	160	13	3	011231375	48,159	16,5	125	184	13	1	011231650	79,498
<b>14</b>	108	160	13	3	011231400	48,159	<b>17</b>	125	184	13	1	011231700	79,498
14,25	114	169	13	3	011231425	57,670	17,5	130	191	13	1	011231750	91,805
<b>14,5</b>	114	169	13	3	011231450	57,670	<b>18</b>	130	191	13	1	011231800	91,805
14,75	114	169	13	3	011231475	57,670	18,5	135	198	13	1	011231850	105,135
<b>15</b>	114	169	13	3	011231500	57,670	<b>19</b>	135	198	13	1	011231900	105,135
15,25	120	178	13	3	011231525	68,652	19,5	140	205	13	1	011231950	119,998
<b>15,5</b>	120	178	13	3	011231550	68,652	<b>20</b>	140	205	13	1	011232000	119,998

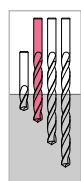

< 5 d



Inox



Acciaio  
Steel



Metals



Velocità di taglio consigliata / Recommended cutting speed

Acciaio / Steel - 15 m/min

Inox - 8 m/min

L'alta percentuale di Cobalto(e Molibdeno) rende questa punta particolarmente resistente alle sollecitazioni meccaniche e termiche e, pertanto, é adatta alle lavorazioni dell'acciaio inox e degli acciai resistenti al calore, di tutti gli acciai alto legati e delle leghe molto tenaci (Acciai al Ni Cr, hastelloy, nimonin, inconel). High performances in cutting stainless steel, alloy steel up to  $R \leq 1400 \text{ N/mm}^2$ . / Pour percer l'acier inox et l'acier allié avec  $R \leq 1400 \text{ N/mm}^2$ . / Para taladar acero inox  $R \leq 1400 \text{ N/mm}^2$ . / Einsatz: Geeignet für legierte Stähle bis  $R \leq 1400 \text{ N/mm}^2$  Zug-Festigkeit Korrosionsbeständige Stähle (V 2A - V 4A etc.), Säure und Hitzebeständige, Grauguss und Stahlguss.

## 01126

### Punte elicoidali al cobalto 8%, serie extra corta

Cobalt straight shank twist drills, stub serie / Forets au cobalt, série extra courte  
Broca de cobalto, serie extra corta / Kobalt Spiralbohrer, extra kurz

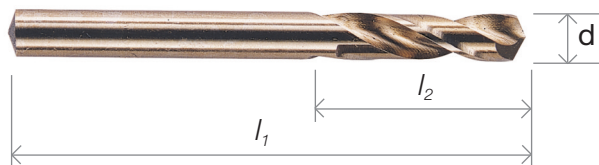
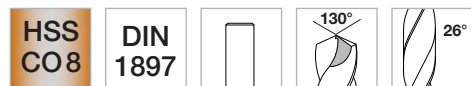

d h8	$l_2$	$l_1$		cod.	€ cad/each
3	16	46	10	011260300	2,142
3,25	18	49	10	011260325	2,722
3,5	20	52	10	011260350	2,722
3,75	20	52	10	011260375	2,991
4	22	55	10	011260400	2,991
4,25	22	55	10	011260425	3,426
4,5	24	58	10	011260450	3,426
4,75	24	58	10	011260475	3,633
5	26	62	10	011260500	3,633
5,5	28	66	10	011260550	4,916
6	28	66	10	011260600	5,123

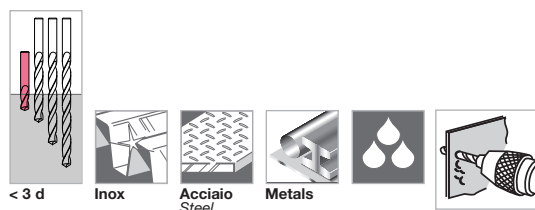

**Velocità di taglio consigliata / Recommended cutting speed**  
**Acciaio / Steel - 15 m/min**  
**Inox - 8 m/min**

L'alta percentuale di Cobalto(e Molibdeno) rende questa punta particolarmente resistente alle sollecitazioni meccaniche e termiche e, pertanto, é adatta alle lavorazioni dell'acciaio inox e degli acciai resistenti al calore, di tutti gli acciai alto legati e delle leghe molto tenaci (Acciai al Ni Cr, hastelloy, nimonic, inconel).  
 High performances in cutting stainless steel, alloy steel up to  $R \leq 1400 \text{ N/mm}^2$ . / Pour percer l'acier inox et l'acier allié avec  $R \leq 1400 \text{ N/mm}^2$ . / Para taladar acero inox  $R \leq 1400 \text{ N/mm}^2$ . / Einsatz: Geeignet für legierte Stähle bis  $R \leq 1400 \text{ N/mm}^2$  Zug-Festigkeit Korrosionsbeständige Stähle (V 2A - V 4A etc.), Säure und Hitzebeständige, Grauguss und Stahlguss.

# 01128

## Punte elicoidali cilindriche al cobalto 8%, serie lunga

Cobalt long straight shank twist drills / Forets cylindriques série longue au cobalt  
Brocas helicoidales serie larga de cobalto / Kobalt Spiralbohrer, lange Ausführung

HSS  
CO 8

DIN  
340

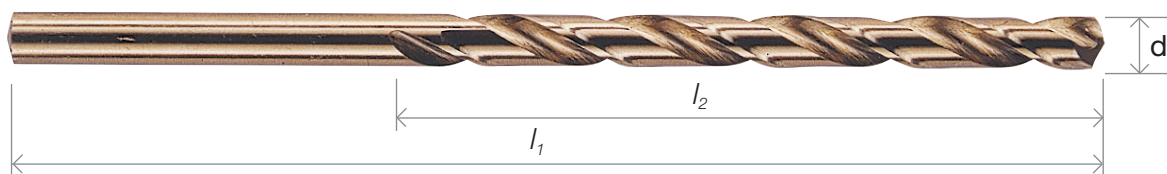

d h8	$l_2$	$l_1$		cod.	€ cad/each
3	66	100	10	011280300	4,451
3,25	69	106	10	011280325	5,009
3,5	73	112	10	011280350	5,009
3,75	73	112	10	011280375	6,034
4	78	119	10	011280400	6,034
4,25	78	119	10	011280425	7,193
4,5	82	126	10	011280450	7,193
4,75	82	126	10	011280475	7,887
5	87	132	10	011280500	7,514
5,25	87	132	10	011280525	9,212
5,5	91	139	10	011280550	8,777

d h8	$l_2$	$l_1$		cod.	€ cad/each
5,75	91	139	10	011280575	11,499
6	91	139	10	011280600	10,961
6,5	97	148	5	011280650	12,834
7	102	156	5	011280700	14,852
7,5	102	156	5	011280750	18,889
8	109	165	5	011280800	21,114
8,5	109	165	5	011280850	24,250
9	115	175	5	011280900	27,635
9,5	115	175	5	011280950	31,826
10	121	184	5	011281000	37,488

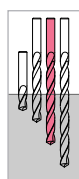

< 8 d



Inox



Acciaio  
Steel



Metals

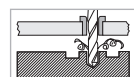

Velocità di taglio consigliata / Recommended cutting speed  
Acciaio / Steel - 15 m/min  
Inox - 8 m/min

L'alta percentuale di Cobalto(e Molibdeno) rende questa punta particolarmente resistente alle sollecitazioni meccaniche e termiche e, pertanto, é adatta alle lavorazioni dell'acciaio inox e degli acciai resistenti al calore, di tutti gli acciai alto legati e delle leghe molto tenaci (Acciai al Ni Cr, hastelloy, nimonin, inconel).  
High performances in cutting stainless steel, alloy steel up to  $R \leq 1400 \text{ N/mm}^2$ . / Pour percer l'acier inox et l'acier allié avec  $R \leq 1400 \text{ N/mm}^2$ . / Para taladar acero inox  $R \leq 1400 \text{ N/mm}^2$ . / Einsatz: Geeignet für legierte Stähle bis  $R \leq 1400 \text{ N/mm}^2$  Zug-Festigkeit Korrosionsbeständige Stähle (V 2A - V 4A etc.), Säure und Hitzebeständige, Grauguss und Stahlguss.



## 01320

Punte elicoidali cilindriche con rivestimento al nitrato di titanio sui taglienti e con angolo al vertice di 118° TiN coated twist drills / Forets cylindriques au nitrure de titan

Brocas helicoidales con recubrimiento de titanio / Geschliffene Spiralbohrer, TiN-beschichtet

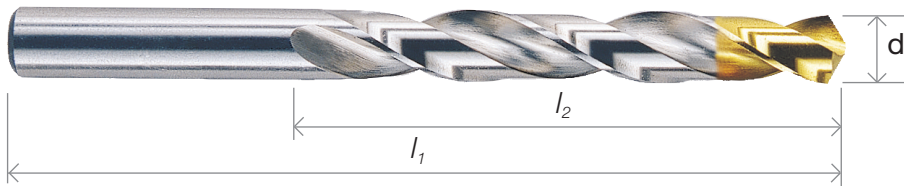
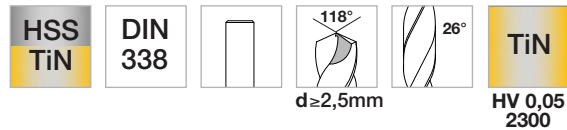

d h8	l <sub>2</sub>	l <sub>1</sub>		cod.	€ cad/each
2	24	49	10	013200200	1,201
2,25	27	53	10	013200225	1,201
2,5	30	57	10	013200250	1,201
2,75	33	61	10	013200275	1,418
2,8	33	61	10	013200280	1,418
3	33	61	10	013200300	1,418
3,2	36	65	10	013200320	1,615
3,25	36	65	10	013200325	1,615
3,3	36	65	10	013200330	1,615
3,4	39	70	10	013200340	1,615
3,5	39	70	10	013200350	1,615
3,7	39	70	10	013200370	1,884
3,75	39	70	10	013200375	1,884
3,8	43	75	10	013200380	1,884
4	43	75	10	013200400	1,884

d h8	l <sub>2</sub>	l <sub>1</sub>		cod.	€ cad/each
4,1	43	75	10	013200410	2,401
4,2	43	75	10	013200420	2,401
4,25	43	75	10	013200425	2,401
4,5	47	80	10	013200450	2,401
4,75	47	80	10	013200475	2,732
4,8	52	86	10	013200480	2,732
5	52	86	10	013200500	2,732
5,2	52	86	10	013200520	3,343
5,25	52	86	10	013200525	3,343
5,5	57	93	10	013200550	3,343
5,75	57	93	10	013200575	3,705
6	57	93	10	013200600	3,705
6,25	63	101	10	013200625	4,357
6,5	63	101	10	013200650	4,357
6,75	69	109	10	013200675	4,906

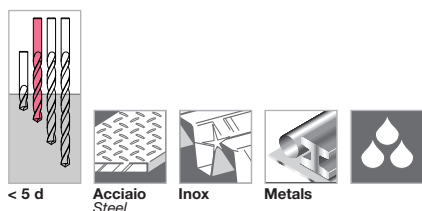

**Velocità di taglio consigliata**  
Recommended cutting speed  
**Acciaio / Steel - 14 m/min**  
**Inox - 7 m/min**

Rendimenti elevati e maggiore durata dei taglienti nella foratura degli acciai legati, nelle ghise e nei metalli in genere. High level of performances in cutting alloy steel, cast iron, metals up to R ≤ 900 N/mm<sup>2</sup> / Pour percer métaux et acier allié avec R ≤ 900 N/mm<sup>2</sup> / Para taladrar acero aleado con elevada velocidad de corte R ≤ 900 N/mm<sup>2</sup> / Einsatz in Stahl und Stahlguss, legiert und unlegiert bis zu einer Zug-Festigkeit von R ≤ 900 N/mm<sup>2</sup>, Temperguss, Sintereisen, Aluminium legiert und unlegiert, Kupfer, Bronze.



**Abs**

19 pcs - Ø 1÷10 x 0,5 mm\*  
**01170311 € 101,161**  
25 pcs - Ø 1÷13 x 0,5 mm\*  
**01170312 € 203,191**

\*Ø 1mm, 1,5 mm Art. 01160



**Metal**  
331x228x48

116 pcs - Ø 1÷10 x 0,5 mm  
\*Ø 1 ÷ 5 mm - 10 pcs  
Ø 5,5 ÷ 8 mm - 3 pcs  
Ø 8,5 ÷ 10 mm - 2 pcs

**01170452 € 372,600**

d h8	$l_2$	$l_1$		cod.	€ cad/each
7	69	109	10	013200700	4,906
7,25	69	109	5	013200725	5,703
7,5	69	109	5	013200750	5,703
7,75	75	117	5	013200775	6,924
8	75	117	5	013200800	6,924
8,25	75	117	5	013200825	8,197
8,5	75	117	5	013200850	8,197
8,75	81	125	5	013200875	8,973
9	81	125	5	013200900	8,973
9,25	81	125	5	013200925	9,957
9,5	81	125	5	013200950	9,957
9,75	87	133	5	013200975	10,950
10	87	133	5	013201000	11,064
10,25	87	133	5	013201025	12,203
10,5	87	133	5	013201050	12,203

d h8	$l_2$	$l_1$		cod.	€ cad/each
10,75	94	142	5	013201075	13,362
11	94	142	5	013201100	13,362
11,25	94	142	5	013201125	14,490
11,5	94	142	5	013201150	14,490
11,75	94	142	5	013201175	16,011
12	101	151	5	013201200	16,011
12,25	101	151	5	013201225	17,719
12,5	101	151	5	013201250	17,719
12,75	101	151	5	013201275	19,375
13	101	151	5	013201300	19,375

### Caratteristiche del rivestimento TiN – Features of TiN coating Caractéristiques du revêtement TiN – Características del recubrimiento TiN

Il rivestimento monostato TiN ha lo scopo di incrementare la resistenza a fenomeni di usura e ossidazione cui gli utensili sono sottoposti durante le lavorazioni di foratura: ha ottime caratteristiche di microdurezza (HV 0,05 2300), un basso coefficiente di attrito (0,4), una temperatura massima di esercizio pari a 500°C. Il rivestimento di pochi  $\mu\text{m}$ , depositato per via fisica mediante vapore (Physical Vapour Deposition), consente pertanto di aumentare la vita utile degli utensili da taglio, migliorando anche la finitura superficiale ed il conseguente scorrimento dei trucioli di lavorazione.

TiN monolayer coating can increase both wear and oxidation resistance of every tool. It has high hardness (HV 0.05 2300), low friction coefficient (0.4), maximum working temperature 500°C. The coating thickness is very low ( $\mu\text{m}$ ) and it's produced by Physical Vapour Deposition. TiN coating increases the life cycle of the tool, also improving the surface finishing and the drilling chips removal.

Le revêtement monocouche TiN sert à augmenter la résistance aux phénomènes d'usure et d'oxydation auxquels les outils sont soumis pendant les travaux de perçage : il possède des caractéristiques optimales de microdureté (HV 0,05 2300), un coefficient de frottement faible (0,4), une température maximale de fonctionnement égale à 500°C. Le revêtement de quelques  $\mu\text{m}$ , déposé par un procédé physique par le biais de la vapeur (Physical Vapour Deposition), permet donc d'augmenter la vie utile des outils de coupe, en améliorant aussi la finition de la surface et donc l'évacuation des copeaux d'usinage produits.

El recubrimiento monocapa TiN tiene la finalidad de aumentar la resistencia al desgaste y a la oxidación que sufren los utensilios durante los trabajos de perforado: tiene óptimas características de microdureza (HV 0,05 2300), un bajo coeficiente de fricción (0,4), una temperatura máxima de funcionamiento equivalente a 500°C. El recubrimiento de pocos  $\mu\text{m}$ , depositado físicamente con vapor (Physical Vapour Deposition), consente aumentar la duración de los utensilios de corte, mejorando también el acabado superficial y el consiguiente deslaminamiento de las virutas generadas durante la actividad.

## 01160

### Punte elicoidali cilindriche con rivestimento al nitruro di titanio

TiN coated twist drills / Forets cylindriques au nitruro de titan

Brocas helicoidales con recubrimiento de titanio / Geschliffene Spiralboher, TiN-beschichtet

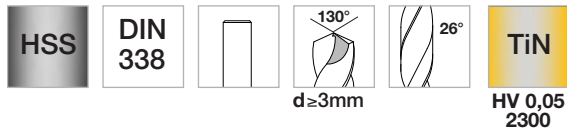

d h8	$l_2$	$l_1$		cod.	€ cad/each
1	12	34	10	011600100	1,066
1,1	14	36	10	011600110	1,066
1,2	16	38	10	011600120	1,066
1,25	16	38	10	011600125	0,963
1,3	16	38	10	011600130	0,963
1,4	18	40	10	011600140	0,963
1,5	18	40	10	011600150	0,890
1,6	20	43	10	011600160	1,201
1,7	20	43	10	011600170	1,201
1,75	22	46	10	011600175	1,087
1,8	22	46	10	011600180	1,128
1,9	22	46	10	011600190	1,128
2	24	49	10	011600200	1,035
2,1	24	49	10	011600210	1,201
2,2	27	53	10	011600220	1,201
2,25	27	53	10	011600225	1,201
2,3	27	53	10	011600230	1,201
2,4	30	57	10	011600240	1,201
2,5	30	57	10	011600250	1,087
2,6	30	57	10	011600260	1,470
2,7	33	61	10	011600270	1,470
2,75	33	61	10	011600275	1,470
2,8	33	61	10	011600280	1,470

d h8	$l_2$	$l_1$		cod.	€ cad/each
2,9	33	61	10	011600290	1,470
3	33	61	10	011600300	1,335
3,1	36	65	10	011600310	1,594
3,2	36	65	10	011600320	1,594
3,25	36	65	10	011600325	1,594
3,3	36	65	10	011600330	1,594
3,4	39	70	10	011600340	1,594
3,5	39	70	10	011600350	1,449
3,6	39	70	10	011600360	1,677
3,7	39	70	10	011600370	1,677
3,75	39	70	10	011600375	1,677
3,8	43	75	10	011600380	1,677
3,9	43	75	10	011600390	1,677
4	43	75	10	011600400	1,521
4,1	43	75	10	011600410	2,008
4,2	43	75	10	011600420	2,008
4,25	43	75	10	011600425	2,008
4,3	47	80	10	011600430	2,008
4,4	47	80	10	011600440	2,008
4,5	47	80	10	011600450	1,822
4,6	47	80	10	011600460	2,184
4,7	47	80	10	011600470	2,184
4,75	47	80	10	011600475	2,184

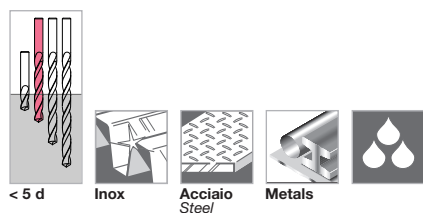

**Velocità di taglio consigliata / Recommended cutting speed**  
**Acciaio / Steel - 14 m/min**  
**Inox - 7 m/min**



Rendimenti elevati e maggiore durata dei taglienti nella foratura degli acciai legati, nelle ghise e nei metalli in genere con  $R \leq 900 \text{ N/mm}^2$ . High level of performances in cutting alloy steel, cast iron, metals up to  $R \leq 900 \text{ N/mm}^2$  / Pour percer métaux et acier allié avec  $R \leq 900 \text{ N/mm}^2$  / Para taladrar acero aleado con elevada velocidad de corte  $R \leq 900 \text{ N/mm}^2$  / Einsatz in Stahl und Stahlguss, legiert und unlegiert bis zu einer Zug-Festigkeit von  $R \leq 900 \text{ N/mm}^2$ , Temperguss, Sintereisen, Aluminium legiert und unlegiert, Kupfer, Bronze.

19 pcs -  $\varnothing 1 \div 10 \times 0,5 \text{ mm}$   
**01170301 € 52,785**  
 25 pcs -  $\varnothing 1 \div 13 \times 0,5 \text{ mm}$   
**01170302 € 117,990**

d h8	$l_2$	$l_1$		cod.	€ cad/each
4,8	52	86	10	011600480	2,184
4,9	52	86	10	011600490	2,184
<b>5</b>	52	86	10	011600500	1,987
5,1	52	86	10	011600510	2,660
5,2	52	86	10	011600520	2,660
<b>5,25</b>	52	86	10	011600525	2,660
5,3	52	86	10	011600530	2,660
5,4	57	93	10	011600540	2,660
<b>5,5</b>	57	93	10	011600550	2,422
5,6	57	93	10	011600560	2,990
5,7	57	93	10	011600570	2,990
<b>5,75</b>	57	93	10	011600575	2,990
5,8	57	93	10	011600580	2,990
5,9	57	93	10	011600590	2,990
<b>6</b>	57	93	10	011600600	2,650
6,1	63	101	10	011600610	3,271
6,2	63	101	10	011600620	3,271
<b>6,25</b>	63	101	10	011600625	3,271
6,3	63	101	10	011600630	3,271
6,4	63	101	10	011600640	3,271
<b>6,5</b>	63	101	10	011600650	2,970
6,6	63	101	10	011600660	3,643
6,7	63	101	10	011600670	3,643
<b>6,75</b>	69	109	10	011600675	3,643
6,8	69	109	10	011600680	3,643
6,9	69	109	10	011600690	3,643
<b>7</b>	69	109	10	011600700	3,302
7,1	69	109	5	011600710	4,513
7,2	69	109	5	011600720	4,513
<b>7,25</b>	69	109	5	011600725	4,513
7,3	69	109	5	011600730	4,513
7,4	69	109	5	011600740	4,513
<b>7,5</b>	69	109	5	011600750	4,099
7,6	75	117	5	011600760	5,247
7,7	75	117	5	011600770	5,247
<b>7,75</b>	75	117	5	011600775	5,247
7,8	75	117	5	011600780	5,247
7,9	75	117	5	011600790	5,247
<b>8</b>	75	117	5	011600800	4,771
8,1	75	117	5	011600810	6,376
8,2	75	117	5	011600820	6,376
<b>8,25</b>	75	117	5	011600825	6,376
8,3	75	117	5	011600830	6,376
8,4	75	117	5	011600840	6,376
<b>8,5</b>	75	117	5	011600850	5,786

d h8	$l_2$	$l_1$		cod.	€ cad/each
8,6	81	125	5	011600860	6,914
8,7	81	125	5	011600870	6,914
<b>8,75</b>	81	125	5	011600875	6,914
8,8	81	125	5	011600880	6,914
8,9	81	125	5	011600890	6,914
<b>9</b>	81	125	5	011600900	6,293
9,1	81	125	5	011600910	7,814
9,2	81	125	5	011600920	7,814
<b>9,25</b>	81	125	5	011600925	7,814
9,3	81	125	5	011600930	7,814
9,4	81	125	5	011600940	7,814
<b>9,5</b>	81	125	5	011600950	7,110
9,6	87	133	5	011600960	8,135
9,7	87	133	5	011600970	8,135
<b>9,75</b>	87	133	5	011600975	8,135
9,8	87	133	5	011600980	8,135
9,9	87	133	5	011600990	8,135
<b>10</b>	87	133	5	011601000	7,400
10,25	87	133	5	011601025	9,098
<b>10,5</b>	87	133	5	011601050	8,270
10,75	94	142	5	011601075	9,833
<b>11</b>	94	142	5	011601100	8,932
11,25	94	142	5	011601125	10,702
<b>11,5</b>	94	142	5	011601150	9,729
11,75	94	142	5	011601175	11,292
<b>12</b>	101	151	5	011601200	11,592
12,25	101	151	5	011601225	12,368
<b>12,5</b>	101	151	5	011601250	12,627
12,75	101	151	5	011601275	13,755
<b>13</b>	101	151	5	011601300	13,352
13,5	108	160	3	011601350	22,408
<b>14</b>	108	160	3	011601400	24,147
14,5	114	169	3	011601450	26,765
<b>15</b>	114	169	3	011601500	28,783
15,5	120	178	3	011601550	31,806
<b>16</b>	120	178	3	011601600	33,772
16,5	125	184	1	011601650	36,763
<b>17</b>	125	184	1	011601700	39,020
17,5	130	191	1	011601750	42,394
<b>18</b>	130	191	1	011601800	44,836
18,5	135	198	1	011601850	48,479
<b>19</b>	135	198	1	011601900	51,201
19,5	140	205	1	011601950	52,847
<b>20</b>	140	205	1	011602000	55,290

## 01170

### Assortimenti punte al titanio in scatole di metallo

Sets of TiN coated twist drills / Assortiments forets au titan

Juego brocas de titanio / HSS-TiN Spiralbohrersätze

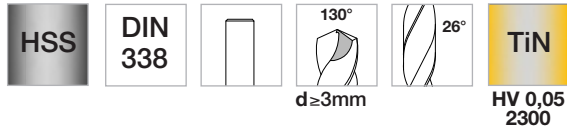

Metal

49 pcs - Ø 1÷13 x 0,25 mm

01170412 € 251,878

91 pcs - Ø 1÷10 x 0,1 mm

01170410 € 436,584

37 pcs - Ø 1÷10 x 0,25 mm

01170411 € 119,025

91 pcs - Ø 1÷10 x 0,1 mm **Plastic box**

01170220 € 330,237

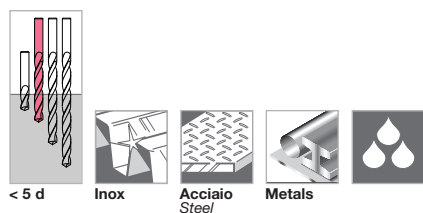

**Velocità di taglio consigliata / Recommended cutting speed**

**Acciaio / Steel - 14 m/min**

**Inox - 7 m/min**



01170301

Rendimenti elevati e maggiore durata dei taglienti nella foratura degli acciai legati, nelle ghise e nei metalli in genere con  $R \leq 900 \text{ N/mm}^2$ . High level of performances in cutting alloy steel, cast iron, metals up to  $R \leq 900 \text{ N/mm}^2$  / Pour percer métaux et acier allié avec  $R \leq 900 \text{ N/mm}^2$  / Para taladrar acero aleado con elevada velocidad de corte  $R \leq 900 \text{ N/mm}^2$  / Einsatz in Stahl und Stahlguss, legiert und unlegiert bis zu einer Zug-Festigkeit von  $R \leq 900 \text{ N/mm}^2$ , Temperguss, Sintereisen, Aluminium legiert und unlegiert, Kupfer, Bronze.

# 01170

## Assortimenti punte al titanio in scatole di metallo

Sets of TiN coated twist drills / Assortiments forets au titan

Juego brocas de titanio / HSS-TiN Spiralbohrersätze



Metal

116 pcs - Ø 1÷10 x 0,5 mm  
Ø 1 ÷ 5 mm - 10 pcs  
Ø 5,5 ÷ 8 mm - 3 pcs  
Ø 8,5 ÷ 10 mm - 2 pcs

01170450 € 238,050

 331x228x48

128 pcs - Ø 1÷13 x 0,5 mm  
Ø 1 ÷ 5 mm - 10 pcs  
Ø 5,5 ÷ 8 mm - 3 pcs  
Ø 8,5 ÷ 13 mm - 2 pcs

01170451 € 412,965

 497x266x59

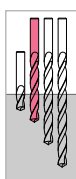

< 5 d



Inox



Acciaio  
Steel



Metals



Velocità di taglio consigliata / Recommended cutting speed

Acciaio / Steel - 14 m/min

Inox - 7 m/min

Rendimenti elevati e maggiore durata dei taglienti nella foratura degli acciai legati, nelle ghise e nei metalli in genere con  $R \leq 900 \text{ N/mm}^2$ . High level of performances in cutting alloy steel, cast iron, metals up to  $R \leq 900 \text{ N/mm}^2$  / Pour percer métaux et acier allié avec  $R \leq 900 \text{ N/mm}^2$  / Para taladrar acero aleado con elevada velocidad de corte  $R \leq 900 \text{ N/mm}^2$  / Einsatz in Stahl und Stahlguss, legiert und unlegiert bis zu einer Zug-Festigkeit von  $R \leq 900 \text{ N/mm}^2$ , Temperguss, Sinterisen, Aluminium legiert und unlegiert, Kupfer, Bronze.

## 01163

### Punte elicoidali cilindriche rivestite al TiN con codolo ridotto

Reduced shank TiN coated twist drills / Forets cylindriques au nitrure de titan à queue degagé

Brocas helicoidales con recubrimiento de titanio y mango reducido / Geschliffene Spiralbohrer TiN-beschichtet mit reduzierten Schaft

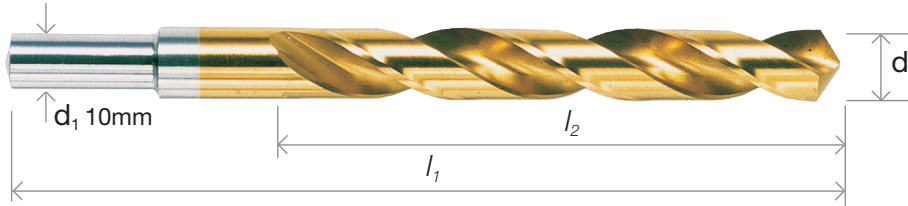
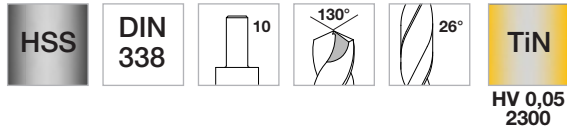

d	$l_2$	$l_1$	$d_1$		cod.	€ cad/each	d	$l_2$	$l_1$	$d_1$		cod.	€ cad/each
10,25	87	133	10	5	011631025	11,106	14	108	160	10	3	011631400	26,848
<b>10,5</b>	87	133	10	5	011631050	10,257	14,5	114	169	10	3	011631450	29,466
10,75	94	142	10	5	011631075	11,840	<b>15</b>	114	169	10	3	011631500	31,485
<b>11</b>	94	142	10	5	011631100	10,919	15,5	120	178	10	3	011631550	34,507
11,25	94	142	10	5	011631125	12,699	<b>16</b>	120	178	10	3	011631600	36,473
11,5	94	142	10	5	011631150	11,706	16,5	125	184	10	1	011631650	39,465
11,75	94	142	10	5	011631175	13,238	<b>17</b>	125	184	10	1	011631700	41,721
<b>12</b>	101	151	10	5	011631200	13,455	17,5	130	191	10	1	011631750	45,095
12,25	101	151	10	5	011631225	15,215	<b>18</b>	130	191	10	1	011631800	47,527
12,5	101	151	10	5	011631250	15,629	18,5	135	198	10	1	011631850	51,181
12,75	101	151	10	5	011631275	16,043	<b>19</b>	135	198	10	1	011631900	53,903
<b>13</b>	101	151	10	5	011631300	15,732	19,5	140	205	10	1	011631950	55,548
13,5	108	160	10	3	011631350	25,109	<b>20</b>	140	205	10	1	011632000	57,981

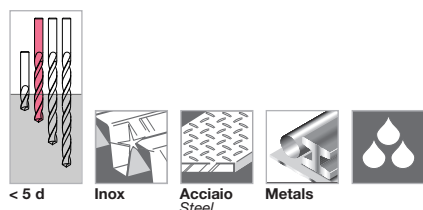

**Velocità di taglio consigliata / Recommended cutting speed**  
**Acciaio / Steel - 14 m/min**  
**Inox - 7 m/min**

Rendimenti elevati e maggiore durata dei taglienti nella foratura degli acciai legati, nelle ghise e nei metalli in genere con  $R \leq 900$  N/mm<sup>2</sup>. High level of performances in cutting alloy steel, cast iron, metals up to  $R \leq 900$  N/mm<sup>2</sup> / Pour percer métaux et acier allié avec  $R \leq 900$  N/mm<sup>2</sup> / Para taladrar acero aleado con elevada velocidad de corte  $R \leq 900$  N/mm<sup>2</sup> / Einsatz in Stahl und Stahlguss, legiert und unlegiert bis zu einer Zug-Festigkeit von  $R \leq 900$  N/mm<sup>2</sup>, Temperguss, Sintereisen, Aluminium legiert und unlegiert, Kupfer, Bronze.

# 01164

## Punte elicoidali cilindriche rivestite al TiN con codolo ridotto

Reduced shank TiN coated twist drills / Forets cylindriques au nitrure de titan à queue degagé

Brocas helicoidales con recubrimiento de titanio y mango reducido / Geschliffene Spiralbohrer TiN-beschichtet mit reduzierten Schaft

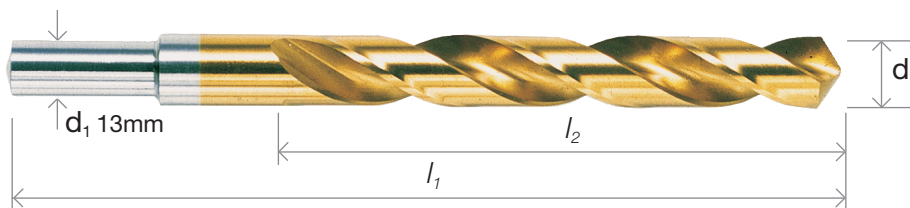
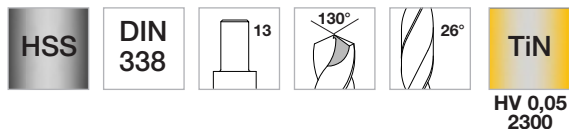

d	$l_2$	$l_1$	$d_1$		cod.	€ cad/each
13,5	108	160	13	3	011641350	25,109
<b>14</b>	108	160	13	3	011641400	26,848
14,5	114	169	13	3	011641450	29,466
<b>15</b>	114	169	13	3	011641500	31,485
15,5	120	178	13	3	011641550	34,507
<b>16</b>	120	178	13	3	011641600	36,473
16,5	125	184	13	1	011641650	39,465
<b>17</b>	125	184	13	1	011641700	41,721
17,5	130	191	13	1	011641750	45,095
<b>18</b>	130	191	13	1	011641800	47,527
18,5	135	198	13	1	011641850	51,181
<b>19</b>	135	198	13	1	011641900	53,903
19,5	140	205	13	1	011641950	55,548
<b>20</b>	140	205	13	1	011642000	57,981

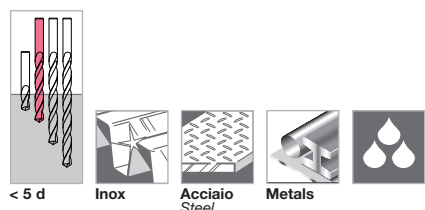

**Velocità di taglio consigliata / Recommended cutting speed**  
**Acciaio / Steel - 14 m/min**  
**Inox - 7 m/min**

Rendimenti elevati e maggiore durata dei taglienti nella foratura degli acciai legati, nelle ghise e nei metalli in genere con  $R \leq 900 \text{ N/mm}^2$ . High level of performances in cutting alloy steel, cast iron, metals up to  $R \leq 900 \text{ N/mm}^2$  / Pour percer métaux et acier allié avec  $R \leq 900 \text{ N/mm}^2$  / Para taladrar acero aleado con elevada velocidad de corte  $R \leq 900 \text{ N/mm}^2$  / Einsatz in Stahl und Stahlguss, legiert und unlegiert bis zu einer Zug-Festigkeit von  $R \leq 900 \text{ N/mm}^2$ , Temperguss, Sinterisen, Aluminium legiert und unlegiert, Kupfer, Bronze.



## 01166

### Punte elicoidali cilindriche rettificate rivestite al TiN, serie extra corta

HSS-G TiN coated twist drills, stub serie / Forets au nitrure de Titan, série extra courte

Brocas de Titanio serie extra corta / TiN-beschichtet Spiralbohrer, extra kurz

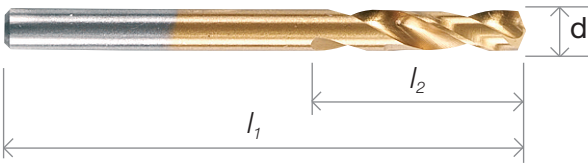
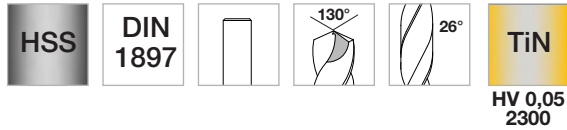

d h8	$l_2$	$l_1$		cod.	€ cad/each
3	16	46	10	011660300	1,335
3,25	18	49	10	011660325	1,594
3,5	20	52	10	011660350	1,449
3,75	20	52	10	011660375	1,677
4	22	55	10	011660400	1,521
4,5	24	58	10	011660450	1,822
5	26	62	10	011660500	1,987
5,5	28	66	10	011660550	2,422
6	28	66	10	011660600	2,650

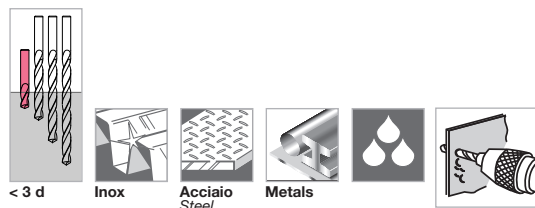

**Velocità di taglio consigliata / Recommended cutting speed**  
**Acciaio / Steel - 14 m/min**  
**Inox - 7 m/min**

Rendimenti elevati e maggiore durata dei taglienti nella foratura degli acciai legati, nelle ghise e nei metalli in genere con  $R \leq 900 \text{ N/mm}^2$ . High level of performances in cutting alloy steel, cast iron, metals up to  $R \leq 900 \text{ N/mm}^2$  / Pour percer métaux et acier allié avec  $R \leq 900 \text{ N/mm}^2$  / Para taladrar acero aleado con elevada velocidad de corte  $R \leq 900 \text{ N/mm}^2$  / Einsatz in Stahl und Stahlguss, legiert und unlegiert bis zu einer Zug-Festigkeit von  $R \leq 900 \text{ N/mm}^2$ , Temperguss, Sintereisen, Aluminium legiert und unlegiert, Kupfer, Bronze.

# 01168

## Punte elicoidali cilindriche rettificate rivestite al TiN, serie lunga

HSS-G TiN coated twist drills, long serie / Forets au nitrure de Titan, série longue

Brocas de Titanio serie larga / TiN-beschichtet Spiralbohrer, lange Ausführung

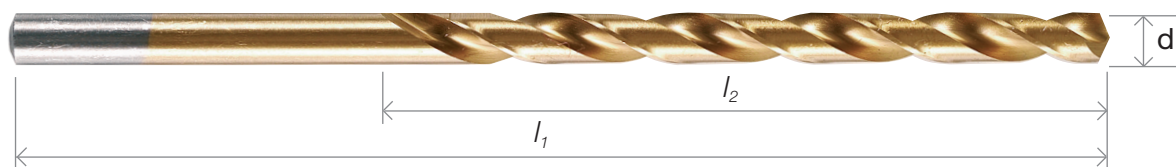
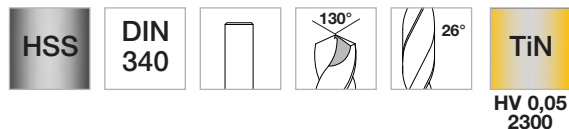

d h8	$l_2$	$l_1$		cod.	€ cad/each
3	66	100	10	011680300	2,546
3,25	69	106	10	011680325	2,681
3,5	73	112	10	011680350	2,681
3,75	73	112	10	011680375	2,981
4	78	119	10	011680400	2,981
4,25	78	119	10	011680425	3,426
4,5	82	126	10	011680450	3,426
4,75	82	126	10	011680475	3,861
5	87	132	10	011680500	3,861
5,25	87	132	10	011680525	4,513
5,5	91	139	10	011680550	4,513

d h8	$l_2$	$l_1$		cod.	€ cad/each
5,75	91	139	10	011680575	4,968
6	91	139	10	011680600	4,968
6,5	97	148	5	011680650	5,227
7	102	156	5	011680700	6,728
7,5	102	156	5	011680750	8,073
8	109	165	5	011680800	9,833
8,5	109	165	5	011680850	11,520
9	115	175	5	011680900	12,627
9,5	115	175	5	011680950	13,869
10	121	184	5	011681000	16,146

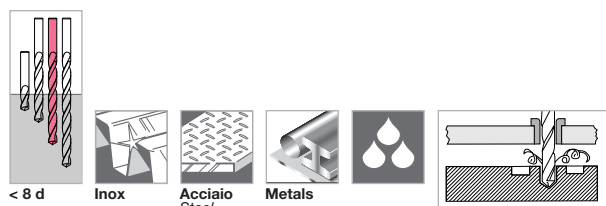

**Velocità di taglio consigliata / Recommended cutting speed**  
**Acciaio / Steel - 14 m/min**  
**Inox - 7 m/min**

Rendimenti elevati e maggiore durata dei taglienti nella foratura degli acciai legati, nelle ghise e nei metalli in genere con  $R \leq 900 \text{ N/mm}^2$ . High level of performances in cutting alloy steel, cast iron, metals up to  $R \leq 900 \text{ N/mm}^2$  / Pour percer métaux et acier allié avec  $R \leq 900 \text{ N/mm}^2$  / Para taladrar acero aleado con elevada velocidad de corte  $R \leq 900 \text{ N/mm}^2$  / Einsatz in Stahl und Stahlguss, legiert und unlegiert bis zu einer Zug-Festigkeit von  $R \leq 900 \text{ N/mm}^2$ , Temperguss, Sintereisen, Aluminium legiert und unlegiert, Kupfer, Bronze.

## 01171

### Punta fresa per rimuovere punti di saldatura e per forare lamiera in genere

Spot drills / Fraise pour points de soudure

Fresas para puntos de soldaduras / Schweisspunktbohrer

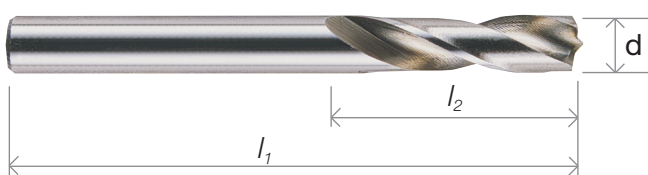
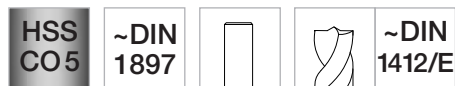

d	$l_2$	$l_1$	cod.	€ cad/each
6	30	66	0117106	12,234
7	36	74	0117107	13,755
8	38	79	0117108	14,553
10	45	89	0117110	18,527

## 01169

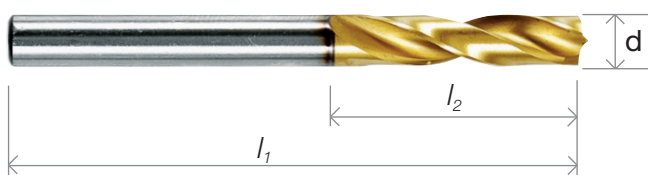
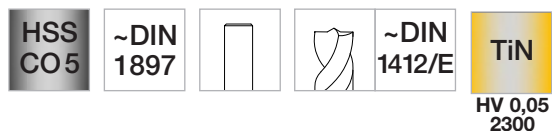

d	$l_2$	$l_1$	cod.	€ cad/each
6	30	66	011690600	17,667
7	36	74	011690700	20,979
8	38	79	011690800	23,184
10	45	89	011691000	28,742

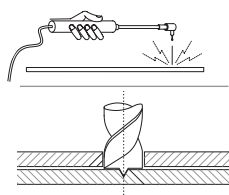

Grazie all'affilatura piatta 180°, l'utensile fora solamente la lamiera superiore per rimuovere la saldatura e non danneggia la lamiera inferiore, che rimane intatta. The tool damages only the first metal sheet in order to remove the welding spot. This is achieved thanks to 180° sharpening of the point. The second metal sheet is undamaged. / Grâce à l'affûtage à plat 180°, l'outil perce uniquement la tôle supérieure pour enlever la soudure et n'endommage pas la tôle inférieure qui reste intact. / Gracias al afilado plano 180°, el utensilio perfora solamente la plancha superior para quitar la soldadura y no daña la plancha inferior, que permanece intacta. / Dank des Flachschliffs von 180° bohrt das Werkzeug nur das obere Blech, um die Schweißstelle zu entfernen und beschädigt nicht das untere Blech, das intakt bleibt.

01172

01173

## Punta fresa per rimuovere punti di saldatura con macchine pneumatiche

Milling drill for removing spot welds with pneumatic tools / Fraise pour enlever les points de soudure avec machines pneumatiques

Fresa para quitar los puntos de soldadura con las máquinas neumáticas / Schweißpunktfräser für pneumatische Maschinen

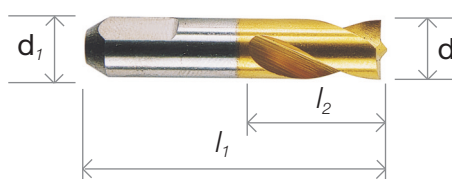
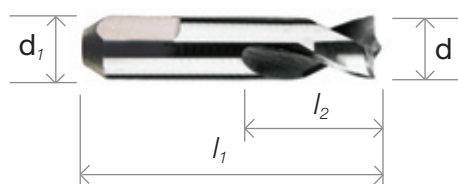
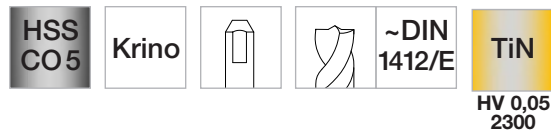
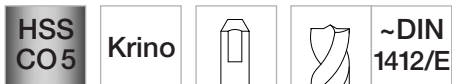

d	d <sub>1</sub>	l <sub>2</sub>	l <sub>1</sub>	cod.	€ cad/each
6,5	6,5	17	40	011720650	14,221
6,5 vario	8	18	44	011720650V	14,221
8	8	17	40	011720800	16,208
8 vario	8	18	44	011720800V	16,208

d	d <sub>1</sub>	l <sub>2</sub>	l <sub>1</sub>	cod.	€ cad/each
6,5	6,5	17	40	011730650	17,543
6,5 vario	8	18	44	011730650V	17,543
8	8	17	40	011730800	20,514
8 vario	8	18	44	011730800V	20,514

01179

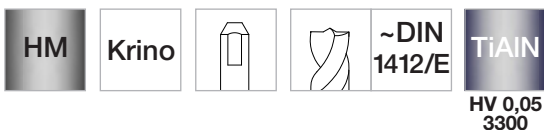

## METALLO DURO/CARBIDE

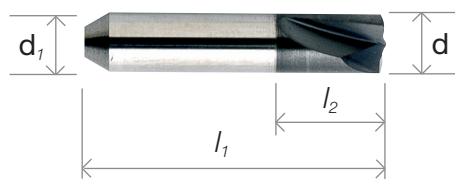

d	d <sub>1</sub>	l <sub>2</sub>	l <sub>1</sub>	cod.	€ cad/each
6,5	6,5	17	40	011790650	118,663
8	8	17	40	011790800	118,663
10	8	18	44	011791000	147,767

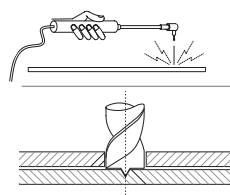

Grazie all'affilatura piatta 180°, l'utensile fora solamente la lamiera superiore per rimuovere la saldatura e non danneggia la lamiera inferiore, che rimane intatta. The tool damages only the first metal sheet in order to remove the welding spot. This is achieved thanks to 180° sharpening of the point. The second metal sheet is undamaged. / Grâce à l'affûtage à plat 180°, l'outil perce uniquement la tôle supérieure pour enlever la soudure et n'endommage pas la tôle inférieure qui reste intact. / Gracias al afilado plano 180°, el utensilio perfora solamente la plancha superior para quitar la soldadura y no daña la plancha inferior, que permanece intacta. / Dank des Flachschliffs von 180° bohrt das Werkzeug nur das obere Blech, um die Schweißstelle zu entfernen und beschädigt nicht das untere Blech, das intakt bleibt.

## 01089

### Punte elicoidali cilindriche in metallo duro integrale

Tungsten carbide drill bits / Forets en carbure

Broca de metal duro / Hartmetall Spiralbohrer

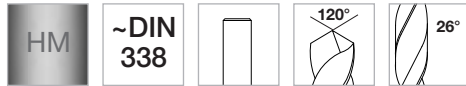

## METALLO DURO/CARBIDE

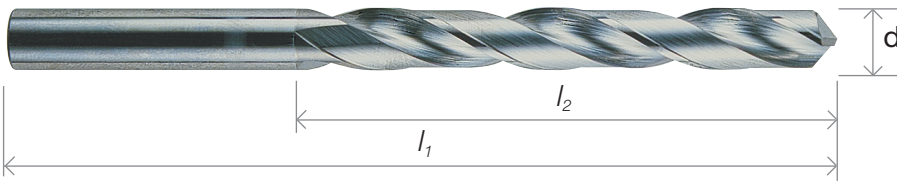

d h7	$l_2$	$l_1$		cod.	€ cad/each	d h7	$l_2$	$l_1$		cod.	€ cad/each
1	12	34	1	010890100	8,011	3,5	39	70	1	010890350	23,681
1,1	14	36	1	010890110	9,284	3,6	39	70	1	010890360	25,430
1,2	16	38	1	010890120	9,688	3,7	39	70	1	010890370	25,637
1,3	16	38	1	010890130	9,419	3,8	43	75	1	010890380	27,521
1,4	18	40	1	010890140	9,356	3,9	43	75	1	010890390	27,986
1,5	18	40	1	010890150	8,880	4	43	75	1	010890400	28,463
1,6	20	43	1	010890160	9,015	4,1	43	75	1	010890410	28,866
1,7	20	43	1	010890170	9,822	4,2	43	75	1	010890420	28,794
1,8	22	46	1	010890180	9,895	4,3	47	80	1	010890430	32,427
1,9	22	46	1	010890190	10,029	4,4	47	80	1	010890440	32,499
2	24	49	1	010890200	13,320	4,5	47	80	1	010890450	33,503
2,1	24	49	1	010890210	14,335	4,6	47	80	1	010890460	33,710
2,2	27	53	1	010890220	15,339	4,7	47	80	1	010890470	34,579
2,3	27	53	1	010890230	15,142	4,8	52	86	1	010890480	39,423
2,4	30	57	1	010890240	16,891	4,9	52	86	1	010890490	40,437
2,5	30	57	1	010890250	17,295	5	52	86	1	010890500	39,154
2,6	30	57	1	010890260	17,968	5,1	52	86	1	010890510	42,249
2,7	33	61	1	010890270	20,317	5,2	52	86	1	010890520	42,859
2,8	33	61	1	010890280	19,779	5,3	52	86	1	010890530	43,263
2,9	33	61	1	010890290	19,779	5,4	57	93	1	010890540	48,303
3	33	61	1	010890300	19,644	5,5	57	93	1	010890550	47,030
3,1	36	65	1	010890310	22,335	5,6	57	93	1	010890560	48,707
3,2	36	65	1	010890320	21,600	5,7	57	93	1	010890570	51,936
3,3	36	65	1	010890330	21,600	5,8	57	93	1	010890580	50,322
3,4	39	70	1	010890340	23,888	5,9	57	93	1	010890590	51,605

Rivestimento TiAIN disponibile su richiesta (art. n. 01308)  
TiAIN coating available on demand (code n. 01308)



HV 0,05  
3300

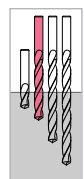

3-5 d



Acciaio  
Steel



Metals



Plastics



Velocità di taglio consigliata / Recommended cutting speed

Acciaio / Steel - 60 m/min

Plastiche / Plastics - 60 m/min

Taglio di ghisa, acciai duri al manganese, bronzi e metalli abrasivi, plastiche rinforzate con fibre. / Suitable for cutting into cast iron, Mn hard steel, bronzes, abrasive materials, fiber reinforced plastics. / Découpe de la fonte, des aciers durs au manganèse, des bronzes et des métaux abrasifs, des matières plastiques renforcées avec fibres. / Corte de hierro fundido, aceros duros al manganesio, bronzes y metales abrasivos y plásticos reforzados con fibras. / Schneiden von Gusseisen, Manganhartstählen, Bronzen und Schleifmetalle, faserverstärkte Kunststoffe.

d h7	$l_2$	$l_1$		cod.	€ cad/each	d h7	$l_2$	$l_1$		cod.	€ cad/each
6	57	93	1	010890600	49,514	8,5	75	117	1	010890850	101,523
6,1	63	101	1	010890610	59,678	8,6	81	125	1	010890860	122,244
6,2	63	101	1	010890620	59,409	8,7	81	125	1	010890870	121,975
6,3	63	101	1	010890630	60,009	8,8	81	125	1	010890880	121,167
6,4	63	101	1	010890640	64,180	8,9	81	125	1	010890890	123,786
6,5	63	101	1	010890650	62,700	9	81	125	1	010890900	118,073
6,6	63	101	1	010890660	64,046	9,1	81	125	1	010890910	124,997
6,7	63	101	1	010890670	65,060	9,2	81	125	1	010890920	135,492
6,8	69	109	1	010890680	72,057	9,3	81	125	1	010890930	134,353
6,9	69	109	1	010890690	73,733	9,4	81	125	1	010890940	136,165
7	69	109	1	010890700	72,191	9,5	81	125	1	010890950	131,528
7,1	69	109	1	010890710	74,406	9,6	87	133	1	010890960	146,929
7,2	69	109	1	010890720	82,748	9,7	87	133	1	010890970	146,121
7,3	69	109	1	010890730	83,897	9,8	87	133	1	010890980	142,488
7,4	69	109	1	010890740	82,013	9,9	87	133	1	010890990	145,583
7,5	69	109	1	010890750	80,865	10	87	133	1	010891000	139,528
7,6	75	117	1	010890760	93,181	10,2	87	133	1	010891020	164,824
7,7	75	117	1	010890770	93,854	10,5	87	133	1	010891050	163,209
7,8	75	117	1	010890780	91,090	10,8	94	142	1	010891080	163,209
7,9	75	117	1	010890790	92,301	11	94	142	1	010891100	189,519
8	75	117	1	010890800	89,548	11,5	94	142	1	010891150	208,149
8,1	75	117	1	010890810	104,814	12	101	151	1	010891200	234,593
8,2	75	117	1	010890820	103,811						
8,3	75	117	1	010890830	104,618						
8,4	75	117	1	010890840	104,752						

### Caratteristiche del metallo duro - Features of hard metal Caractéristiques du metal dur - Características del metal duro

Il metallo duro è un prodotto sinterizzato costituito principalmente da WC e Co in proporzioni variabili. Da questa proporzione dipendono le caratteristiche specifiche dell'utensile: la qualità a grana fine K20 che usiamo per i nostri prodotti è composta dal 94% di WC e dal restante 6% di Co e presenta una resistenza a rottura di 2200 MPa e una durezza di 91,9 HVA. Tale prodotto è caratterizzato da un'ottima resistenza a usura e da una discreta resistenza a flessione anche se, naturalmente, si consiglia di evitare qualsiasi urto o eccessivo sforzo flettente. Vista l'elevata durezza, l'utensile è infatti discretamente fragile e sensibile a condizioni di lavoro non omogenee. Si consideri poi che il metallo duro è mediamente rigido il doppio rispetto all'acciaio superrapido: pertanto, con punte in metallo duro, si producono di norma fori molto più cilindrici.

The hard metal is produced by sintering of WC and Co powders. The main features of the product depend on the content of these 2 components: we chose K20 fine grain type, which means 94% WC and 6% Co, with 2200 MPa resistance and 91,9 HVA hardness. This product has an excellent wear resistance and a good bending resistance. By the way, it's recommended to avoid any accidental crash, because the product is very hard and thus fragile. The hard metal stiffness is quite double comparing to the high speed steel one: you can drill "very cylindrical" holes with an hard metal tool.

Le métal dur est un produit fritté constitué principalement de WC et Co en proportions variables. C'est de ces proportions que dépendent les caractéristiques spécifiques de l'outil : la qualité à grain fin K20 que nous utilisons pour nos produits est composée de 94% de WC et du restant 6% de Co et présente une résistance à la rupture de 2200 MPa et une dureté de 91,9 HVA. Ce produit se distingue par une excellente résistance à l'usure et à une résistance correcte à la flexion aunque, naturellement, se aconseja evitar cualquier golpe o excesivo esfuerzo de flexión. Étant donnée la dureté élevée, l'outil est en fait assez fragile et sensible aux conditions de travail non homogènes. Il faut aussi considérer que le métal dur est en moyenne deux fois plus rigide que l'acier super rapide : de fait, des trous bien plus cylindriques sont produits en général avec des forets en métal dur.

El metal duro es un producto sinterizado constituido principalmente por WC y Co en proporciones variables. De esta proporción dependen las características específicas del utensilio: el tipo de grano fino K20 que usamos para nuestros productos está formado por el 94% de WC y por el restante 6% de Co; y presenta una resistencia a la ruptura de 2200 MPa y una dureza de 91,9 HVA. Este producto se caracteriza por una óptima resistencia al desgaste y por una discreta resistencia a la flexión aunque, naturalmente, se aconseja evitar cualquier golpe o excesivo esfuerzo de flexión. Considerada la elevada dureza, el utensilio es bastante frágil y sensible en condiciones de trabajo no homogéneas. Hay que considerar que el metal duro es medianamente el doble de rígido con respecto al acero super rápido: por tanto, con puntas de metal duro, normalmente se realizan orificios mucho más cilíndricos.

## 01119

### Punte elicoidali cilindriche in metallo duro integrale, serie extra corta

Tungsten carbide drill bits, extra short series / Forets en carbure

Broca de metal duro / Hartmetall Spiralbohrer

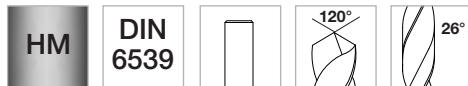

## METALLO DURO/CARBIDE

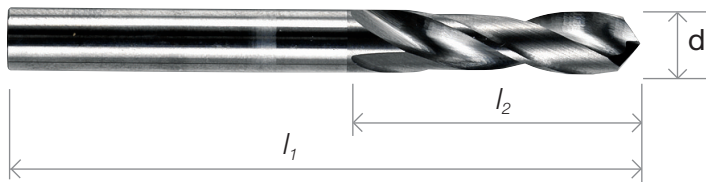

d h7	l <sub>2</sub>	l <sub>1</sub>		cod.	€ cad/each
0,5	6	26	1	011190050	12,182
0,6	6	26	1	011190060	11,644
0,7	6	26	1	011190070	10,702
0,8	6	26	1	011190080	9,626
0,9	6	26	1	011190090	9,222
<b>1</b>	6	26	1	011190100	<b>6,396</b>
1,1	7	28	1	011190110	7,669
1,2	8	30	1	011190120	7,473
1,3	8	30	1	011190130	7,338
1,4	9	32	1	011190140	7,266
<b>1,5</b>	9	32	1	011190150	<b>6,800</b>
1,6	10	34	1	011190160	6,593
1,7	10	34	1	011190170	7,266
1,8	11	36	1	011190180	7,535
1,9	11	36	1	011190190	7,535
<b>2</b>	12	38	1	011190200	<b>11,168</b>
2,1	12	38	1	011190210	11,975
2,2	13	40	1	011190220	12,782
2,3	13	40	1	011190230	12,720
2,4	14	43	1	011190240	13,724
<b>2,5</b>	14	43	1	011190250	<b>14,066</b>
2,6	14	43	1	011190260	14,531
2,7	16	46	1	011190270	16,415
2,8	16	46	1	011190280	15,815
2,9	16	46	1	011190290	15,949
<b>3</b>	16	46	1	011190300	<b>15,815</b>
3,1	18	49	1	011190310	17,968

d h7	l <sub>2</sub>	l <sub>1</sub>		cod.	€ cad/each
3,2	18	49	1	011190320	17,564
3,3	18	49	1	011190330	17,833
3,4	20	52	1	011190340	18,837
<b>3,5</b>	20	52	1	011190350	<b>18,568</b>
3,6	20	52	1	011190360	20,317
3,7	20	52	1	011190370	20,183
3,8	22	55	1	011190380	21,663
3,9	22	55	1	011190390	21,797
<b>4</b>	22	55	1	011190400	<b>22,139</b>
4,1	22	55	1	011190410	22,739
4,2	22	55	1	011190420	22,335
4,3	24	58	1	011190430	24,157
4,4	24	58	1	011190440	24,157
<b>4,5</b>	24	58	1	011190450	<b>24,830</b>
4,6	24	58	1	011190460	25,637
4,7	24	58	1	011190470	25,699
4,8	26	62	1	011190480	29,466
4,9	26	62	1	011190490	30,077
<b>5</b>	26	62	1	011190500	<b>28,928</b>
5,1	26	62	1	011190510	31,216
5,2	26	62	1	011190520	31,692
5,3	26	62	1	011190530	32,095
5,4	28	66	1	011190540	35,790
<b>5,5</b>	28	66	1	011190550	<b>34,383</b>
5,6	28	66	1	011190560	35,459
5,7	28	66	1	011190570	36,855
5,8	28	66	1	011190580	36,855

Rivestimento TiAlN disponibile su richiesta (art. n. 01309)  
TiAlN coating available on demand (code n. 01309)

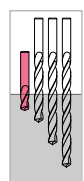

≤ 3 d



Acciaio  
Steel



Metals



Plastics





Velocità di taglio consigliata / Recommended cutting speed

Acciaio / Steel - 60 m/min

Plastiche / Plastics - 60 m/min

Taglio di ghisa, acciai duri al manganese, bronzi e metalli abrasivi, plastiche rinforzate con fibre. / Suitable for cutting into cast iron, Mn hard steel, bronzes, abrasive materials, fiber reinforced plastics. / Découpe de la fonte, des aciers durs au manganèse, des bronzes et des métaux abrasifs, des matières plastiques renforcées avec fibres. / Corte de hierro fundido, aceros duros al manganesio, bronzes y metales abrasivos y plásticos reforzados con fibras. / Schneiden von Gusseisen, Manganhartstählen, Bronzen und Schleifmetalle, faserverstärkte Kunststoffe.

d h7	$l_2$	$l_1$		cod.	€ cad/each
5,9	28	66	1	011190590	37,074
<b>6</b>	28	66	1	011190600	35,925
6,1	31	70	1	011190610	42,859
6,2	31	70	1	011190620	43,325
6,3	31	70	1	011190630	43,532
6,4	31	70	1	011190640	45,954
<b>6,5</b>	31	70	1	011190650	45,074
6,6	31	70	1	011190660	46,285
6,7	31	70	1	011190670	47,165
6,8	34	74	1	011190680	51,264
6,9	34	74	1	011190690	52,278
<b>7</b>	34	74	1	011190700	50,798
7,1	34	74	1	011190710	53,354
7,2	34	74	1	011190720	59,067
7,3	34	74	1	011190730	59,813
7,4	34	74	1	011190740	58,933
<b>7,5</b>	34	74	1	011190750	57,794
7,6	36	79	1	011190760	63,239
7,7	36	79	1	011190770	63,508
7,8	36	79	1	011190780	62,431
7,9	36	79	1	011190790	63,580
<b>8</b>	36	79	1	011190800	60,817
8,1	36	79	1	011190810	63,311
8,2	36	79	1	011190820	66,271
8,3	36	79	1	011190830	67,410
8,4	36	79	1	011190840	67,679
<b>8,5</b>	36	79	1	011190850	65,257
8,6	40	84	1	011190860	81,403

d h7	$l_2$	$l_1$		cod.	€ cad/each
8,7	40	84	1	011190870	81,672
8,8	40	84	1	011190880	80,802
8,9	40	84	1	011190890	82,013
<b>9</b>	40	84	1	011190900	78,784
9,1	40	84	1	011190910	81,672
9,2	40	84	1	011190920	90,552
9,3	40	84	1	011190930	90,687
9,4	40	84	1	011190940	92,105
<b>9,5</b>	40	84	1	011190950	88,803
9,6	43	89	1	011190960	97,280
9,7	43	89	1	011190970	97,621
9,8	43	89	1	011190980	96,203
9,9	43	89	1	011190990	98,760
<b>10</b>	43	89	1	011191000	93,585
10,2	43	89	1	011191020	107,040
<b>10,5</b>	43	89	1	011191050	107,174
10,8	47	95	1	011191080	111,542
<b>11</b>	47	95	1	011191100	122,109
11,5	47	95	1	011191150	146,121
<b>12</b>	51	102	1	011191200	161,864
12,5	51	102	1	011191250	165,569
<b>13</b>	51	102	1	011191300	181,715
13,5	54	107	1	011191350	408,897
<b>14</b>	54	107	1	011191400	208,760
14,5	56	111	1	011191450	214,276
<b>15</b>	56	111	1	011191500	225,444
15,5	58	115	1	011191550	529,454
<b>16</b>	58	115	1	011191600	280,071



## 01361

### Punte a centrare in metallo duro integrale per centri di lavoro CNC-90°

Solid carbide center drills for CNC / Forets à centrer en carbure pour CNC

Brocas de puntear CNC en metal duro integral / Hartmetall Zentrierbohrer für CNC



## METALLO DURO/CARBIDE

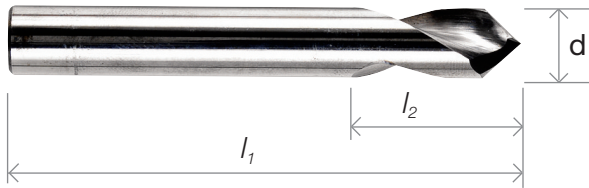

d h7	$l_2$	$l_1$		cod.	€ cad/each
5	10	50	1	013610500	40,303
6	15	50	1	013610600	52,392
8	20	63	1	013610800	72,543
10	22	72	1	013611000	100,747
12	22	73	1	013611200	161,201
14	25	75	1	013611400	217,350
16	25	82	1	013611600	282,100
20	30	104	1	013612000	483,604

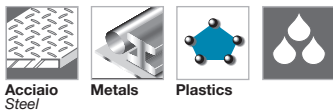

# 01363

## Punte a centrare in metallo duro integrale per centri di lavoro CNC-120°

Solid carbide center drills for CNC / Forets à centrer en carbure pour CNC

Brocas de puntear CNC en metal duro integral / Hartmetall Zentrierbohrer für CNC



### METALLO DURO/CARBIDE

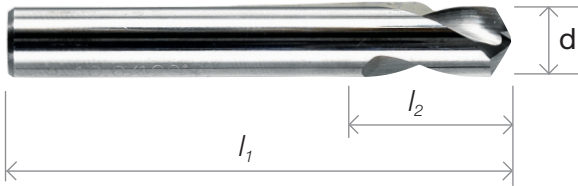

d h7	$l_2$	$l_1$		cod.	€ cad/each
5	10	50	1	013630500	40,303
6	15	50	1	013630600	52,392
8	20	63	1	013630800	72,543
10	22	72	1	013631000	100,747
12	22	73	1	013631200	161,201
14	25	75	1	013631400	217,350
16	25	82	1	013631600	282,100
20	30	104	1	013632000	483,604

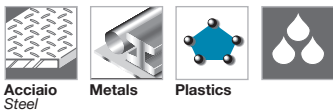

## 01368

### Punte in metallo duro integrale rivestite TiAlN con gambo rinforzato, serie corta

TiAlN coated tungsten carbide drill bits with reinforced shank, short serie / Forets en carbure, série courte, avec TiAlN Broca de metal duro, serie corta con TiAlN / Hartmetall Spiralbohrer, kurz Ausführung, mit TiAlN

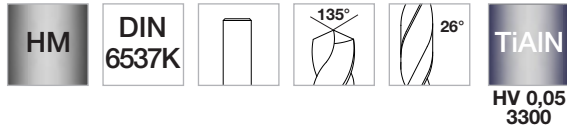

## METALLO DURO/CARBIDE

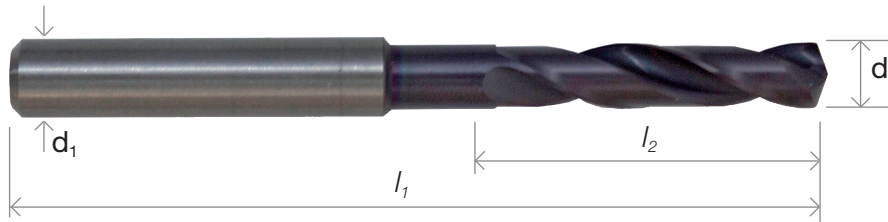

d	d <sub>1</sub>	l <sub>2</sub>	l <sub>1</sub>		cod.	€ cad/each
m7	h6					
3	6	20	62	1	013680300	76,901
3,1	6	20	62	1	013680310	76,901
3,2	6	20	62	1	013680320	76,901
3,3	6	20	62	1	013680330	76,901
3,4	6	20	62	1	013680340	76,901
3,5	6	20	62	1	013680350	76,901
3,6	6	20	62	1	013680360	76,901
3,7	6	20	62	1	013680370	76,901
3,8	6	24	66	1	013680380	76,901
3,9	6	24	66	1	013680390	76,901
4	6	24	66	1	013680400	76,901
4,1	6	24	66	1	013680410	76,901
4,2	6	24	66	1	013680420	76,901
4,3	6	24	66	1	013680430	76,901
4,4	6	24	66	1	013680440	76,901
4,5	6	24	66	1	013680450	76,901
4,6	6	24	66	1	013680460	76,901
4,7	6	28	66	1	013680470	76,901
4,8	6	28	66	1	013680480	76,901
4,9	6	28	66	1	013680490	76,901
5	6	28	66	1	013680500	76,901

d	d <sub>1</sub>	l <sub>2</sub>	l <sub>1</sub>		cod.	€ cad/each
m7	h6					
5,1	6	28	66	1	013680510	76,901
5,2	6	28	66	1	013680520	76,901
5,3	6	28	66	1	013680530	76,901
5,4	6	28	66	1	013680540	76,901
5,5	6	28	66	1	013680550	76,901
5,6	6	28	66	1	013680560	76,901
5,7	6	28	66	1	013680570	76,901
5,8	6	28	66	1	013680580	76,901
5,9	6	28	66	1	013680590	76,901
6	6	28	66	1	013680600	76,901
6,1	8	34	79	1	013680610	76,901
6,2	8	34	79	1	013680620	76,901
6,3	8	34	79	1	013680630	76,901
6,4	8	34	79	1	013680640	76,901
6,5	8	34	79	1	013680650	76,901
6,6	8	34	79	1	013680660	76,901
6,7	8	34	79	1	013680670	76,901
6,8	8	34	79	1	013680680	76,901
6,9	8	34	79	1	013680690	76,901
7	8	34	79	1	013680700	76,901
7,1	8	41	79	1	013680710	76,901

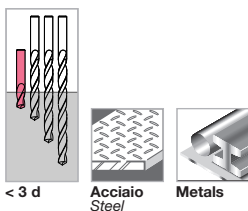

**Velocità di taglio consigliata / Recommended cutting speed**  
**Acciaio / Steel - 60 m/min**

Acciai duri, acciai per lavorazioni a caldo, acciai legati fino a 1200 N/mm<sup>2</sup>, acciai dolci, bronzo, ghisa, leghe Al-Si. Structural and case hardened steels, cast steels, heat treatable steels, alloyed steels up to 1200 N/mm<sup>2</sup>, carbon steels, bronze, cast iron, Al-Si alloys. / Aciers durs, aciers pour usinages à chaud, aciers alliés jusqu'à 1200 N/mm<sup>2</sup>, aciers doux, bronze, fonte, alliages Al-Si. / Aceros duros, aceros para trabajos en caliente, aceros ligados hasta 1200 N/mm<sup>2</sup>, aceros dulces, bronze, hierro fundido, aleaciones Al-Si. / Bau- und Einsatzstähle, Stahlguss, Vergütungsstähle, legierte Stähle bis 1200 N/mm<sup>2</sup>, Kohlenstoffstähle, Bronze, Gusseisen, Al-Si-Legierungen.

d	d <sub>1</sub>	l <sub>2</sub>	l <sub>1</sub>		cod.	€
m7	h6					cad/each
7,2	8	41	79	1	013680720	76,901
7,3	8	41	79	1	013680730	76,901
7,4	8	41	79	1	013680740	76,901
<b>7,5</b>	8	41	79	1	013680750	76,901
7,6	8	41	79	1	013680760	76,901
7,7	8	41	79	1	013680770	76,901
7,8	8	41	79	1	013680780	76,901
7,9	8	41	79	1	013680790	76,901
<b>8</b>	8	41	79	1	013680800	76,901
8,1	10	47	89	1	013680810	86,247
8,2	10	47	89	1	013680820	86,247
8,3	10	47	89	1	013680830	86,247
8,4	10	47	89	1	013680840	86,247
<b>8,5</b>	10	47	89	1	013680850	86,247
8,6	10	47	89	1	013680860	86,247
8,7	10	47	89	1	013680870	86,247
8,8	10	47	89	1	013680880	86,247
8,9	10	47	89	1	013680890	86,247
<b>9</b>	10	47	89	1	013680900	86,247
9,1	10	47	89	1	013680910	86,247
9,2	10	47	89	1	013680920	86,247
9,3	10	47	89	1	013680930	86,247

d	d <sub>1</sub>	l <sub>2</sub>	l <sub>1</sub>		cod.	€
m7	h6					cad/each
9,4	10	47	89	1	013680940	86,247
<b>9,5</b>	10	47	89	1	013680950	86,247
9,6	10	47	89	1	013680960	86,247
9,7	10	47	89	1	013680970	86,247
9,8	10	47	89	1	013680980	86,247
<b>10</b>	10	47	89	1	013681000	86,247
10,2	12	55	102	1	013681020	128,630
10,5	12	55	102	1	013681050	128,630
<b>11</b>	12	55	102	1	013681100	128,630
11,5	12	55	102	1	013681150	128,630
<b>12</b>	12	55	102	1	013681200	128,630
12,5	14	60	107	1	013681250	172,628
<b>13</b>	14	60	107	1	013681300	172,628
13,5	14	60	107	1	013681350	172,628
<b>14</b>	14	60	107	1	013681400	172,628
14,5	16	65	115	1	013681450	222,680
<b>15</b>	16	65	115	1	013681500	222,680
15,5	16	65	115	1	013681550	222,680
<b>16</b>	16	65	115	1	013681600	222,680

## 01366

### Punte in metallo duro integrale rivestite TiAlN con gambo rinforzato, serie corta

TiAlN coated tungsten carbide drill bits with reinforced shank, short serie / Forets en carbure, série courte, avec TiAlN Broca de metal duro, serie corta con TiAlN / Hartmetall Spiralbohrer, kurz Ausführung, mit TiAlN

HM

DIN  
6537K

TiAlN  
**HV 0,05  
3300**

Fori di refrigerazione interna  
Internal coolant holes

METALLO DURO/CARBIDE

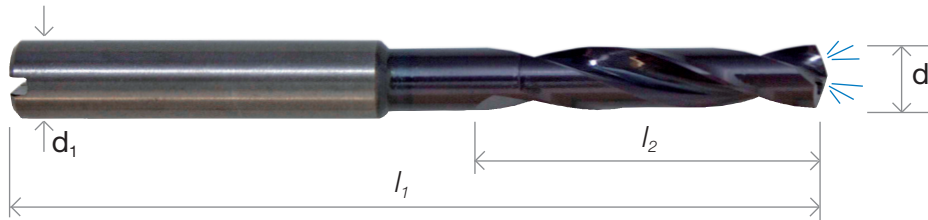

d	d <sub>1</sub>	l <sub>2</sub>	l <sub>1</sub>		cod.	€ cad/each
m7	h6					
3	6	20	62	1	013660300	97,083
3,1	6	20	62	1	013660310	97,083
3,2	6	20	62	1	013660320	97,083
3,3	6	20	62	1	013660330	97,083
3,4	6	20	62	1	013660340	97,083
3,5	6	20	62	1	013660350	97,083
3,6	6	20	62	1	013660360	97,083
3,7	6	20	62	1	013660370	97,083
3,8	6	24	66	1	013660380	97,083
3,9	6	24	66	1	013660390	97,083
4	6	24	66	1	013660400	105,218
4,1	6	24	66	1	013660410	105,218
4,2	6	24	66	1	013660420	105,218
4,3	6	24	66	1	013660430	105,218
4,4	6	24	66	1	013660440	105,218
4,5	6	24	66	1	013660450	105,218
4,6	6	24	66	1	013660460	105,218
4,7	6	28	66	1	013660470	105,218
4,8	6	28	66	1	013660480	105,218
4,9	6	28	66	1	013660490	105,218
5	6	28	66	1	013660500	105,218

d	d <sub>1</sub>	l <sub>2</sub>	l <sub>1</sub>		cod.	€ cad/each
m7	h6					
5,1	6	28	66	1	013660510	105,218
5,2	6	28	66	1	013660520	105,218
5,3	6	28	66	1	013660530	105,218
5,4	6	28	66	1	013660540	105,218
5,5	6	28	66	1	013660550	105,218
5,6	6	28	66	1	013660560	105,218
5,7	6	28	66	1	013660570	105,218
5,8	6	28	66	1	013660580	105,218
5,9	6	28	66	1	013660590	105,218
6	6	28	66	1	013660600	105,218
6,1	8	34	79	1	013660610	142,758
6,2	8	34	79	1	013660620	142,758
6,3	8	34	79	1	013660630	142,758
6,4	8	34	79	1	013660640	142,758
6,5	8	34	79	1	013660650	142,758
6,6	8	34	79	1	013660660	142,758
6,7	8	34	79	1	013660670	142,758
6,8	8	34	79	1	013660680	142,758
6,9	8	34	79	1	013660690	142,758
7	8	34	79	1	013660700	142,758
7,1	8	41	79	1	013660710	142,758

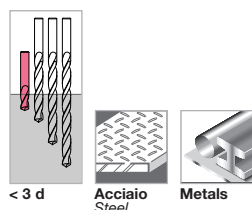

**Velocità di taglio consigliata / Recommended cutting speed**  
**Acciaio / Steel - 60 m/min**

Acciai duri, acciai per lavorazioni a caldo, acciai legati fino a 1200 N/mm<sup>2</sup>, acciai dolci, bronzo, ghisa, leghe Al-Si. Structural and case hardened steels, cast steels, heat treatable steels, alloyed steels up to 1200 N/mm<sup>2</sup>, carbon steels, bronze, cast iron, Al-Si alloys. / Aciers durs, aciers pour usinages à chaud, aciers alliés jusqu'à 1200 N/mm<sup>2</sup>, aciers doux, bronze, fonte, alliages Al-Si. / Aceros duros, aceros para trabajos en caliente, aceros ligados hasta 1200 N/mm<sup>2</sup>, aceros dulces, bronze, hierro fundido, aleaciones Al-Si. / Bau- und Einsatzstähle, Stahlguss, Vergütungsstähle, legierte Stähle bis 1200 N/mm<sup>2</sup>, Kohlenstoffstähle, Bronze, Gusseisen, Al-Si-Legierungen.

d	d <sub>1</sub>	l <sub>2</sub>	l <sub>1</sub>		cod.	€
m7	h6					cad/each
7,2	8	41	79	1	013660720	142,758
7,3	8	41	79	1	013660730	142,758
7,4	8	41	79	1	013660740	142,758
<b>7,5</b>	8	41	79	1	013660750	142,758
7,6	8	41	79	1	013660760	142,758
7,7	8	41	79	1	013660770	142,758
7,8	8	41	79	1	013660780	142,758
7,9	8	41	79	1	013660790	142,758
<b>8</b>	8	41	79	1	013660800	142,758
8,1	10	47	89	1	013660810	160,052
8,2	10	47	89	1	013660820	160,052
8,3	10	47	89	1	013660830	160,052
8,4	10	47	89	1	013660840	160,052
<b>8,5</b>	10	47	89	1	013660850	160,052
8,6	10	47	89	1	013660860	160,052
8,7	10	47	89	1	013660870	160,052
8,8	10	47	89	1	013660880	160,052
8,9	10	47	89	1	013660890	160,052
<b>9</b>	10	47	89	1	013660900	160,052
9,1	10	47	89	1	013660910	160,052
9,2	10	47	89	1	013660920	160,052
9,3	10	47	89	1	013660930	160,052

d	d <sub>1</sub>	l <sub>2</sub>	l <sub>1</sub>		cod.	€
m7	h6					cad/each
9,4	10	47	89	1	013660940	160,052
<b>9,5</b>	10	47	89	1	013660950	160,052
9,6	10	47	89	1	013660960	160,052
9,7	10	47	89	1	013660970	160,052
9,8	10	47	89	1	013660980	160,052
<b>10</b>	10	47	89	1	013661000	160,052
10,2	12	55	102	1	013661020	229,077
10,5	12	55	102	1	013661050	229,077
<b>11</b>	12	55	102	1	013661100	229,077
11,5	12	55	102	1	013661150	229,077
<b>12</b>	12	55	102	1	013661200	229,077
12,5	14	60	107	1	013661250	320,094
<b>13</b>	14	60	107	1	013661300	320,094
13,5	14	60	107	1	013661350	320,094
<b>14</b>	14	60	107	1	013661400	320,094
14,5	16	65	115	1	013661450	390,733
<b>15</b>	16	65	115	1	013661500	390,733
15,5	16	65	115	1	013661550	390,733
<b>16</b>	16	65	115	1	013661600	390,733

## 01369

### Punte in metallo duro integrale rivestite TiAlN con gambo rinforzato, serie lunga

TiAlN coated tungsten carbide drill bits with reinforced shank, long serie / Forets en carbure, série longue, avec TiAlN / Broca de metal duro, serie larga con TiAlN / Hartmetall Spiralbohrer, lange Ausführung, mit TiAlN

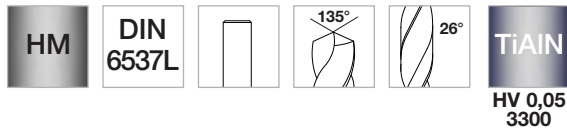

## METALLO DURO/CARBIDE

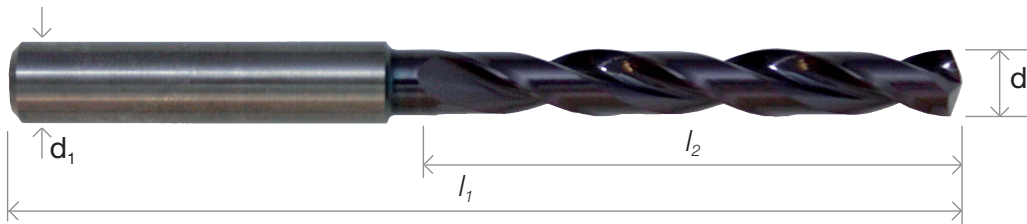

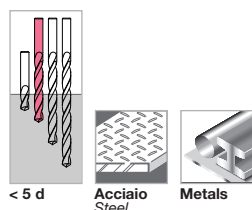

d	d <sub>1</sub>	l <sub>2</sub>	l <sub>1</sub>		cod.	€	d	d <sub>1</sub>	l <sub>2</sub>	l <sub>1</sub>		cod.	€
m7	h6					cad/each	m7	h6					cad/each
3	6	28	66	1	013690300	87,934	5,1	6	44	82	1	013690510	87,934
3,1	6	28	66	1	013690310	87,934	5,2	6	44	82	1	013690520	87,934
3,2	6	28	66	1	013690320	87,934	5,3	6	44	82	1	013690530	87,934
3,3	6	28	66	1	013690330	87,934	5,4	6	44	82	1	013690540	87,934
3,4	6	28	66	1	013690340	87,934	<b>5,5</b>	6	44	82	1	013690550	87,934
<b>3,5</b>	6	28	66	1	013690350	87,934	5,6	6	44	82	1	013690560	87,934
3,6	6	28	66	1	013690360	87,934	5,7	6	44	82	1	013690570	87,934
3,7	6	28	66	1	013690370	87,934	5,8	6	44	82	1	013690580	87,934
3,8	6	36	74	1	013690380	87,934	5,9	6	44	82	1	013690590	87,934
3,9	6	36	74	1	013690390	87,934	<b>6</b>	6	44	82	1	013690600	87,934
<b>4</b>	6	36	74	1	013690400	87,934	6,1	8	53	91	1	013690610	89,476
4,1	6	36	74	1	013690410	87,934	6,2	8	53	91	1	013690620	89,476
4,2	6	36	74	1	013690420	87,934	6,3	8	53	91	1	013690630	89,476
4,3	6	36	74	1	013690430	87,934	6,4	8	53	91	1	013690640	89,476
4,4	6	36	74	1	013690440	87,934	<b>6,5</b>	8	53	91	1	013690650	89,476
<b>4,5</b>	6	36	74	1	013690450	87,934	6,6	8	53	91	1	013690660	89,476
4,6	6	36	74	1	013690460	87,934	6,7	8	53	91	1	013690670	89,476
4,7	6	44	82	1	013690470	87,934	6,8	8	53	91	1	013690680	89,476
4,8	6	44	82	1	013690480	87,934	6,9	8	53	91	1	013690690	89,476
4,9	6	44	82	1	013690490	87,934	<b>7</b>	8	53	91	1	013690700	89,476
<b>5</b>	6	44	82	1	013690500	87,934	7,1	8	53	91	1	013690710	89,476



**Velocità di taglio consigliata / Recommended cutting speed**  
**Acciaio / Steel - 60 m/min**

Acciai duri, acciai per lavorazioni a caldo, acciai legati fino a 1200 N/mm<sup>2</sup>, acciai dolci, bronzo, ghisa, leghe Al-Si. Structural and case hardened steels, cast steels, heat treatable steels, alloyed steels up to 1200 N/mm<sup>2</sup>, carbon steels, bronze, cast iron, Al-Si alloys. / Aciers durs, aciers pour usinages à chaud, aciers alliés jusqu'à 1200 N/mm<sup>2</sup>, aciers doux, bronze, fonte, alliages Al-Si. / Aceros duros, aceros para trabajos en caliente, aceros ligados hasta 1200 N/mm<sup>2</sup>, aceros dulces, bronze, hierro fundido, aleaciones Al-Si. / Bau- und Einsatzstähle, Stahlguss, Vergütungsstähle, legierte Stähle bis 1200 N/mm<sup>2</sup>, Kohlenstoffstähle, Bronze, Gusseisen, Al-Si-Legierungen.

d	d <sub>1</sub>	l <sub>2</sub>	l <sub>1</sub>		cod.	€
m7	h6					cad/each
7,2	8	53	91	1	013690720	89,476
7,3	8	53	91	1	013690730	89,476
7,4	8	53	91	1	013690740	89,476
<b>7,5</b>	8	53	91	1	013690750	89,476
7,6	8	53	91	1	013690760	89,476
7,7	8	53	91	1	013690770	89,476
7,8	8	53	91	1	013690780	89,476
7,9	8	53	91	1	013690790	89,476
<b>8</b>	8	53	91	1	013690800	89,476
8,1	10	61	103	1	013690810	98,832
8,2	10	61	103	1	013690820	98,832
8,3	10	61	103	1	013690830	98,832
8,4	10	61	103	1	013690840	98,832
<b>8,5</b>	10	61	103	1	013690850	98,832
8,6	10	61	103	1	013690860	98,832
8,7	10	61	103	1	013690870	98,832
8,8	10	61	103	1	013690880	98,832
8,9	10	61	103	1	013690890	98,832
<b>9</b>	10	61	103	1	013690900	98,832
9,1	10	61	103	1	013690910	98,832
9,2	10	61	103	1	013690920	98,832
9,3	10	61	103	1	013690930	98,832

d	d <sub>1</sub>	l <sub>2</sub>	l <sub>1</sub>		cod.	€
m7	h6					cad/each
9,4	10	61	103	1	013690940	98,832
<b>9,5</b>	10	61	103	1	013690950	98,832
9,6	10	61	103	1	013690960	98,832
9,7	10	61	103	1	013690970	98,832
9,8	10	61	103	1	013690980	98,832
<b>10</b>	10	61	103	1	013691000	98,832
10,2	12	71	118	1	013691020	147,539
10,5	12	71	118	1	013691050	147,539
<b>11</b>	12	71	118	1	013691100	147,539
11,5	12	71	118	1	013691150	147,539
<b>12</b>	12	71	118	1	013691200	147,539
12,5	14	77	124	1	013691250	194,497
<b>13</b>	14	77	124	1	013691300	194,497
13,5	14	77	124	1	013691350	194,497
<b>14</b>	14	77	124	1	013691400	194,497
14,5	16	83	133	1	013691450	252,550
<b>15</b>	16	83	133	1	013691500	252,550
15,5	16	83	133	1	013691550	252,550
<b>16</b>	16	83	133	1	013691600	252,550



## 01367

### Punte in metallo duro integrale rivestite TiAlN con gambo rinforzato, serie lunga

TiAlN coated tungsten carbide drill bits with reinforced shank, long serie / Forets en carbure, série longue, avec TiAlN / Broca de metal duro, serie larga con TiAlN / Hartmetall Spiralbohrer, lange Ausführung, mit TiAlN

HM

DIN 6537L

TiAlN  
HV 0,05  
3300

Fori di refrigerazione interna  
Internal coolant holes

METALLO DURO/CARBIDE

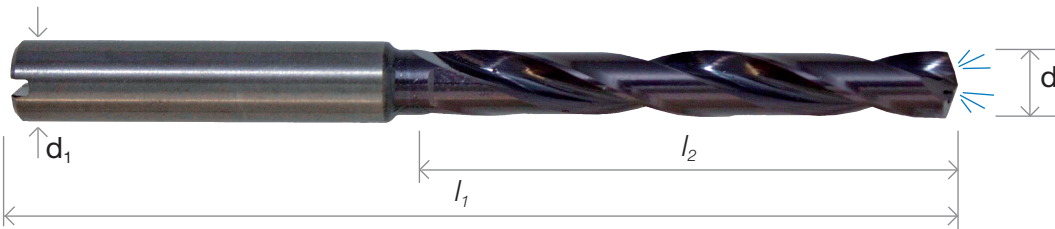

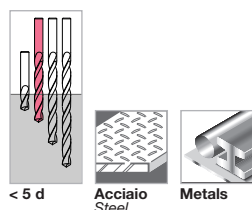

d	d <sub>1</sub>	l <sub>2</sub>	l <sub>1</sub>		cod.	€ cad/each	d	d <sub>1</sub>	l <sub>2</sub>	l <sub>1</sub>		cod.	€ cad/each
m7	h6						m7	h6					
3	6	28	66	1	013670300	125,473	5,1	6	44	82	1	013670510	135,026
3,1	6	28	66	1	013670310	125,473	5,2	6	44	82	1	013670520	135,026
3,2	6	28	66	1	013670320	125,473	5,3	6	44	82	1	013670530	135,026
3,3	6	28	66	1	013670330	125,473	5,4	6	44	82	1	013670540	135,026
3,4	6	28	66	1	013670340	125,473	<b>5,5</b>	6	44	82	1	013670550	135,026
<b>3,5</b>	6	28	66	1	013670350	125,473	5,6	6	44	82	1	013670560	135,026
3,6	6	28	66	1	013670360	125,473	5,7	6	44	82	1	013670570	135,026
3,7	6	28	66	1	013670370	125,473	5,8	6	44	82	1	013670580	135,026
3,8	6	36	74	1	013670380	125,473	5,9	6	44	82	1	013670590	135,026
3,9	6	36	74	1	013670390	125,473	<b>6</b>	6	44	82	1	013670600	135,026
<b>4</b>	6	36	74	1	013670400	135,021	6,1	8	53	91	1	013670610	149,154
4,1	6	36	74	1	013670410	135,021	6,2	8	53	91	1	013670620	149,154
4,2	6	36	74	1	013670420	135,026	6,3	8	53	91	1	013670630	149,154
4,3	6	36	74	1	013670430	135,026	6,4	8	53	91	1	013670640	149,154
4,4	6	36	74	1	013670440	135,026	<b>6,5</b>	8	53	91	1	013670650	149,154
<b>4,5</b>	6	36	74	1	013670450	135,026	6,6	8	53	91	1	013670660	149,154
4,6	6	36	74	1	013670460	135,026	6,7	8	53	91	1	013670670	149,154
4,7	6	44	82	1	013670470	135,026	6,8	8	53	91	1	013670680	149,154
4,8	6	44	82	1	013670480	135,026	6,9	8	53	91	1	013670690	149,154
4,9	6	44	82	1	013670490	135,026	<b>7</b>	8	53	91	1	013670700	149,154
<b>5</b>	6	44	82	1	013670500	135,026	7,1	8	53	91	1	013670710	149,154



**Velocità di taglio consigliata / Recommended cutting speed**  
**Acciaio / Steel - 60 m/min**

Acciai duri, acciai per lavorazioni a caldo, acciai legati fino a 1200 N/mm<sup>2</sup>, acciai dolci, bronzo, ghisa, leghe Al-Si. Structural and case hardened steels, cast steels, heat treatable steels, alloyed steels up to 1200 N/mm<sup>2</sup>, carbon steels, bronze, cast iron, Al-Si alloys. / Aciers durs, aciers pour usinages à chaud, aciers alliés jusqu'à 1200 N/mm<sup>2</sup>, aciers doux, bronze, fonte, alliages Al-Si. / Aceros duros, aceros para trabajos en caliente, aceros ligados hasta 1200 N/mm<sup>2</sup>, aceros dulces, bronze, hierro fundido, aleaciones Al-Si. / Bau- und Einsatzstähle, Stahlguss, Vergütungsstähle, legierte Stähle bis 1200 N/mm<sup>2</sup>, Kohlenstoffstähle, Bronze, Gusseisen, Al-Si-Legierungen.

d m7	d <sub>1</sub> h6	l <sub>2</sub>	l <sub>1</sub>		cod.	€ cad/each
7,2	8	53	91	1	013670720	149,154
7,3	8	53	91	1	013670730	149,154
7,4	8	53	91	1	013670740	149,154
<b>7,5</b>	8	53	91	1	013670750	149,154
7,6	8	53	91	1	013670760	149,154
7,7	8	53	91	1	013670770	149,154
7,8	8	53	91	1	013670780	149,154
7,9	8	53	91	1	013670790	149,154
<b>8</b>	8	53	91	1	013670800	149,154
8,1	10	61	103	1	013670810	170,951
8,2	10	61	103	1	013670820	170,951
8,3	10	61	103	1	013670830	170,951
8,4	10	61	103	1	013670840	170,951
<b>8,5</b>	10	61	103	1	013670850	170,951
8,6	10	61	103	1	013670860	170,951
8,7	10	61	103	1	013670870	170,951
8,8	10	61	103	1	013670880	170,951
8,9	10	61	103	1	013670890	170,951
<b>9</b>	10	61	103	1	013670900	170,951
9,1	10	61	103	1	013670910	170,951
9,2	10	61	103	1	013670920	170,951
9,3	10	61	103	1	013670930	170,951

d m7	d <sub>1</sub> h6	l <sub>2</sub>	l <sub>1</sub>		cod.	€ cad/each
9,4	10	61	103	1	013670940	170,951
<b>9,5</b>	10	61	103	1	013670950	170,951
9,6	10	61	103	1	013670960	170,951
9,7	10	61	103	1	013670970	170,951
9,8	10	61	103	1	013670980	170,951
<b>10</b>	10	61	103	1	013671000	170,951
10,2	12	71	118	1	013671020	249,528
10,5	12	71	118	1	013671050	249,528
<b>11</b>	12	71	118	1	013671100	249,528
11,5	12	71	118	1	013671150	249,528
<b>12</b>	12	71	118	1	013671200	249,528
12,5	14	77	124	1	013671250	335,640
<b>13</b>	14	77	124	1	013671300	335,640
13,5	14	77	124	1	013671350	335,640
<b>14</b>	14	77	124	1	013671400	335,640
14,5	16	83	133	1	013671450	414,145
<b>15</b>	16	83	133	1	013671500	414,145
15,5	16	83	133	1	013671550	414,145
<b>16</b>	16	83	133	1	013671600	414,145

## 01115

Punte elicoidali cilindriche in pollici, esecuzione interamente rettificata, serie corta, finitura brillante

Fully ground straight shank twist drills in inches / Forets cylindriques rectifiés en pouce

Brocas helicoidales rectificadas in pulgada / Geschliffene Spiralbohrer aus Zoll

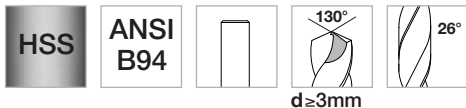

### POLLICI/INCHES

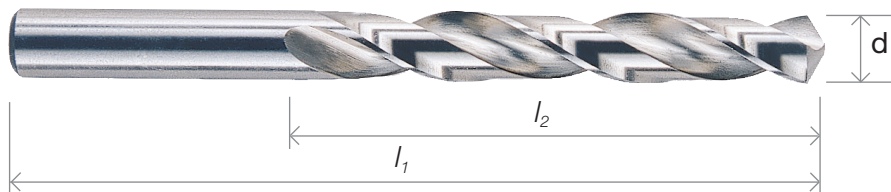

d	d	$l_2$	$l_1$		cod.	€
inch	mm	inch	inch			cad/each
<b>1/16</b>	1,59	7/8	1-7/8	10	<b>01115 14</b>	<b>0,693</b>
<b>5/64</b>	1,98	1"	2"	10	<b>01115 15</b>	<b>0,735</b>
<b>3/32</b>	2,38	1-1/4	2-1/4	10	<b>01115 16</b>	<b>0,849</b>
<b>7/64</b>	2,78	1-1/2	2-5/8	10	<b>01115 17</b>	<b>0,983</b>
<b>1/8</b>	3,17	1-5/8	2-3/4	10	<b>01115 18</b>	<b>1,035</b>
<b>9/64</b>	3,57	1-3/4	2-7/8	10	<b>01115 19</b>	<b>1,149</b>
<b>5/32</b>	3,97	2"	3-1/8	10	<b>01115 20</b>	<b>1,221</b>
<b>11/64</b>	4,37	2-1/8	3-1/4	10	<b>01115 21</b>	<b>1,325</b>
<b>3/16</b>	4,76	2-5/16	3-1/2	10	<b>01115 22</b>	<b>1,501</b>
<b>13/64</b>	5,16	2-7/16	3-5/8	10	<b>01115 23</b>	<b>1,749</b>
<b>7/32</b>	5,56	2-1/2	3-3/4	10	<b>01115 24</b>	<b>1,925</b>
<b>15/64</b>	5,95	2-5/8	3-7/8	10	<b>01115 25</b>	<b>2,029</b>
<b>1/4</b>	6,35	2-3/4	4"	10	<b>01115 26</b>	<b>2,184</b>
<b>17/64</b>	6,75	2-7/8	4-1/8	10	<b>01115 27</b>	<b>2,453</b>
<b>9/32</b>	7,14	2-15/16	4-1/4	5	<b>01115 28</b>	<b>2,857</b>

d	d	$l_2$	$l_1$		cod.	€
inch	mm	inch	inch			cad/each
<b>19/64</b>	7,54	3-1/16	4-3/8	5	<b>01115 29</b>	<b>3,043</b>
<b>5/16</b>	7,94	3-3/16	4-1/2	5	<b>01115 30</b>	<b>3,333</b>
<b>21/64</b>	8,33	3-5/16	4-5/8	5	<b>01115 31</b>	<b>4,606</b>
<b>11/32</b>	8,73	3-7/16	4-3/4	5	<b>01115 32</b>	<b>4,813</b>
<b>23/64</b>	9,13	3-1/2	4-7/8	5	<b>01115 33</b>	<b>5,144</b>
<b>3/8</b>	9,52	3-5/8	5"	5	<b>01115 34</b>	<b>5,247</b>
<b>25/64</b>	9,92	3-3/4	5-1/8	5	<b>01115 35</b>	<b>5,423</b>
<b>13/32</b>	10,32	3-7/8	5-1/4	5	<b>01115 36</b>	<b>5,858</b>
<b>27/64</b>	10,72	3-15/16	5-3/8	5	<b>01115 37</b>	<b>6,552</b>
<b>7/16</b>	11,11	4-1/16	5-1/2	5	<b>01115 38</b>	<b>7,607</b>
<b>29/64</b>	11,51	4-3/16	5-5/8	5	<b>01115 39</b>	<b>7,856</b>
<b>15/32</b>	11,91	4-5/16	5-3/4	5	<b>01115 40</b>	<b>8,228</b>
<b>31/64</b>	12,30	4-7/16	5-7/8	5	<b>01115 41</b>	<b>8,880</b>
<b>1/2</b>	12,70	4-1/2	6"	5	<b>01115 42</b>	<b>9,864</b>

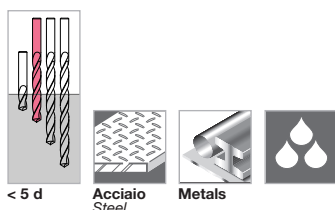

Velocità di taglio consigliata / Recommended cutting speed  
Acciaio / Steel - 10 m/min

Taglio dei materiali con  $R \leq 800 \text{ N/mm}^2$  quali acciai legati, ghise tutti i metalli in genere, la grafite. Precisione di foratura e costanza di rendimenti elevati. High precision and high performances in cutting alloy steel up to  $R \leq 800 \text{ N/mm}^2$  / Puor percer métaux et acier avec  $R \leq 800 \text{ N/mm}^2$  / Para taladrar hierro e acero  $R \leq 800 \text{ N/mm}^2$  / Einsatz in Stahl und Stahlguss, legiert und unlegiert bis  $R \leq 800 \text{ N/mm}^2$  Zug-Festigkeit, Ne-Metalle, Kunststoffe.



21 pcs -  $\varnothing$  1/16÷3/8 x 1/64  
**01118401** € 47,020  
29 pcs -  $\varnothing$  1/16÷1/2 x 1/64  
**01118402** € 108,675

# 01034

## Punte HSS fresate in pollici con codolo ridotto

Reduced shank HSS straight shank twist drills-jobber's length / Forets cylindriques en HSS en Pouce avec queue degagé  
 Broca helicoidal HSS in pulgada con mango reducido / HSS Spiralbohrer aus Zoll mit reduzierten Schaft

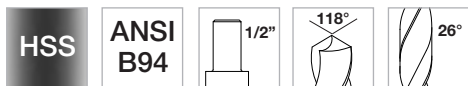

**POLLICI/INCHES**  
**SILVER&DEMING**

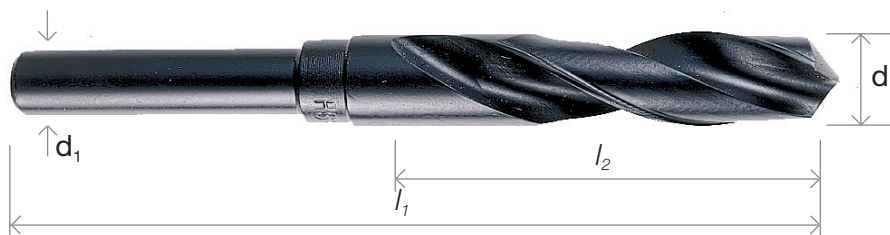

d	d	d <sub>1</sub>	l <sub>2</sub>	l <sub>1</sub>		cod.	€
inch	mm	inch	inch	inch			cad/each
<b>17/32</b>	13,50	1/2"	3-1/8	6"	1	01034 02	<b>10,650</b>
9/16	14,30	1/2"	3-1/8	6"	1	01034 04	10,795
<b>19/32</b>	15,00	1/2"	3-1/8	6"	1	01034 06	<b>12,213</b>
5/8	16,00	1/2"	3-1/8	6"	1	01034 08	12,379
<b>21/32</b>	16,70	1/2"	3-1/8	6"	1	01034 10	<b>13,341</b>
11/16	17,50	1/2"	3-1/8	6"	1	01034 12	14,562
<b>23/32</b>	18,25	1/2"	3-1/8	6"	1	01034 14	<b>15,525</b>
3/4	19,00	1/2"	3-1/8	6"	1	01034 16	16,891
<b>25/32</b>	20,00	1/2"	3-1/8	6"	1	01034 18	<b>17,937</b>
13/16	20,50	1/2"	3-1/8	6"	1	01034 20	19,737
<b>27/32</b>	21,50	1/2"	3-1/8	6"	1	01034 22	<b>21,135</b>
7/8	22,25	1/2"	3-1/8	6"	1	01034 24	23,577
<b>29/32</b>	23,00	1/2"	3-1/8	6"	1	01034 26	<b>26,268</b>
15/16	24,00	1/2"	3-1/8	6"	1	01034 28	28,183
<b>31/32</b>	24,50	1/2"	3-1/8	6"	1	01034 30	<b>31,071</b>
1"	25,40	1/2"	3-1/8	6"	1	01034 32	33,224
<b>1.3/32</b>	27,75	1/2"	3-1/8	6"	1	01034 38	<b>40,262</b>
1.1/8	28,50	1/2"	3-1/8	6"	1	01034 40	40,976
<b>1.1/4</b>	31,75	1/2"	3-1/8	6"	1	01034 48	<b>67,016</b>
1.3/8	35,00	1/2"	3-1/8	6"	1	01034 56	84,777
<b>1.1/2</b>	38,00	1/2"	3-1/8	6"	1	01034 64	<b>126,839</b>

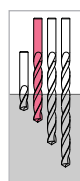

< 5 d



**Velocità di taglio consigliata / Recommended cutting speed**  
**Acciaio / Steel - 10 m/min**

Taglio dei materiali con R ≤ 800 N/mm<sup>2</sup> quali acciai legati, ghise tutti i metalli in genere, la grafite. Precisione di foratura e costanza di rendimenti elevati.  
 High precision and high performances in cutting alloy steel up to R ≤ 800 N/mm<sup>2</sup> / Puor percer métaux et acier avec R ≤ 800 N/mm<sup>2</sup> / Para taladrar hierro e acero R ≤ 800 N/mm<sup>2</sup> / Einsatz in Stahl und Stahlguss, legiert und unlegiert bis R ≤ 800 N/mm<sup>2</sup> Zug-Festigkeit, Ne-Metalle, Kunststoffe.

## 01162

### Punte elicoidali cilindriche con rivestimento al nitruro di titanio

TiN coated twist drills / Forets cylindriques au nitruro de titan

Brocas helicoidales con recubrimiento de titanio / TiN Geschliffene Spiralbohrer aus Zoll

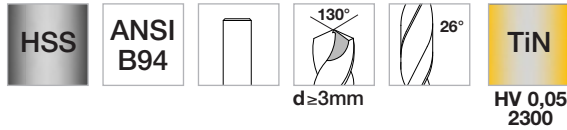

## POLLICI/INCHES

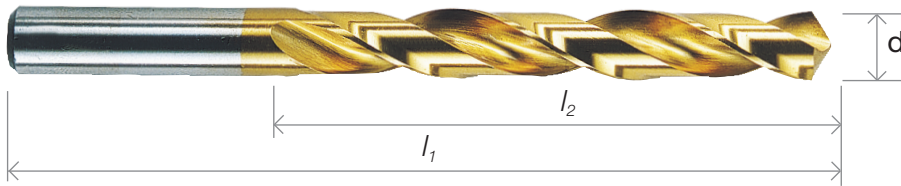

d	d	l <sub>2</sub>	l <sub>1</sub>		cod.	€
inch	mm	inch	inch			cad/each
1/16	1,59	7/8	1-7/8	10	0116214	0,838
5/64	1,98	1"	2"	10	0116215	0,921
3/32	2,38	1-1/4	2-1/4	10	0116216	1,107
7/64	2,78	1-1/2	2-5/8	10	0116217	1,377
1/8	3,17	1-5/8	2-3/4	10	0116218	1,459
9/64	3,57	1-3/4	2-7/8	10	0116219	1,625
5/32	3,97	2"	3-1/8	10	0116220	1,728
11/64	4,37	2-1/8	3-1/4	10	0116221	1,884
3/16	4,76	2-5/16	3-1/2	10	0116222	2,122
13/64	5,16	2-7/16	3-5/8	10	0116223	2,453
7/32	5,56	2-1/2	3-3/4	10	0116224	2,701
15/64	5,95	2-5/8	3-7/8	10	0116225	2,846
1/4	6,35	2-3/4	4"	10	0116226	3,043
17/64	6,75	2-7/8	4-1/8	10	0116227	3,416
9/32	7,14	2-15/16	4-1/4	5	0116228	3,943

d	d	l <sub>2</sub>	l <sub>1</sub>		cod.	€
inch	mm	inch	inch			cad/each
19/64	7,54	3-1/16	4-3/8	5	0116229	4,202
5/16	7,94	3-3/16	4-1/2	5	0116230	4,575
21/64	8,33	3-5/16	4-5/8	5	0116231	6,189
11/32	8,73	3-7/16	4-3/4	5	0116232	6,479
23/64	9,13	3-1/2	4-7/8	5	0116233	6,893
3/8	9,52	3-5/8	5"	5	0116234	7,059
25/64	9,92	3-3/4	5-1/8	5	0116235	7,297
13/32	10,32	3-7/8	5-1/4	5	0116236	7,856
27/64	10,72	3-15/16	5-3/8	5	0116237	8,001
7/16	11,11	4-1/16	5-1/2	5	0116238	9,232
29/64	11,51	4-3/16	5-5/8	5	0116239	9,522
15/32	11,91	4-5/16	5-3/4	5	0116240	9,967
31/64	12,30	4-7/16	5-7/8	5	0116241	10,743
1/2	12,70	4-1/2	6"	5	0116242	11,892

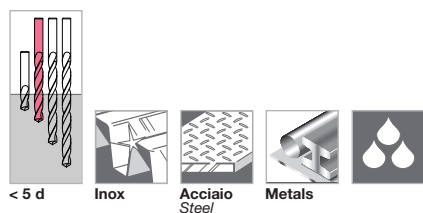

**Velocità di taglio consigliata / Recommended cutting speed**  
**Acciaio / Steel - 14 m/min**  
**Inox - 7 m/min**



Rendimenti elevati e maggiore durata dei taglienti nella foratura degli acciai legati, nelle ghise e nei metalli in genere con R ≤ 900 N/mm<sup>2</sup>. High level of performances in cutting alloy steel, cast iron, metals up to R ≤ 900 N/mm<sup>2</sup> / Pour percer métaux et acier allié avec R ≤ 900 N/mm<sup>2</sup> / Para taladrar acero aleado con elevada velocidad de corte R ≤ 900 N/mm<sup>2</sup> / Einsatz in Stahl und Stahlguss, legiert und unlegiert bis zu einer Zug-Festigkeit von R ≤ 900 N/mm<sup>2</sup>, Temperguss, Sinterisen, Aluminium legiert und unlegiert, Kupfer, Bronze.

21 pcs - Ø 1/16÷3/8 x 1/64  
**01167401 € 53,820**  
 29 pcs - Ø 1/16÷1/2 x 1/64  
**01167402 € 115,920**

# 01157

## Punte elicoidali al cobalto 5% in pollici, esecuzione interamente rettificata, serie corta

Cobalt twist drills ground from the solid in inches / Forets cylindriques au cobalt entièrement rectifiés en pouce  
Broca helicoidal rectificada de cobalto in pulgada / Kobalt Spiralbohrer aus Zoll

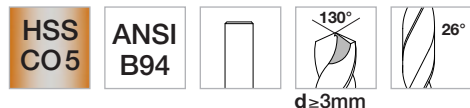

### POLLICI/INCHES

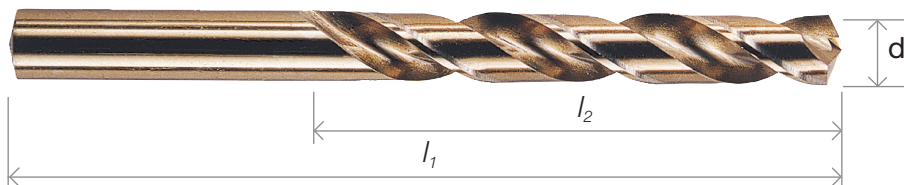

d	d	l <sub>2</sub>	l <sub>1</sub>		cod.	€
inch	mm	inch	inch			cad/each
1/16	1,59	7/8	1-7/8	10	01157 14	1,822
5/64	1,98	1"	2"	10	01157 15	1,822
3/32	2,38	1-1/4	2-1/4	10	01157 16	1,894
7/64	2,78	1-1/2	2-5/8	10	01157 17	1,894
1/8	3,17	1-5/8	2-3/4	10	01157 18	1,894
9/64	3,57	1-3/4	2-7/8	10	01157 19	2,308
5/32	3,97	2"	3-1/8	10	01157 20	2,474
11/64	4,37	2-1/8	3-1/4	10	01157 21	2,805
3/16	4,76	2-5/16	3-1/2	10	01157 22	3,043
13/64	5,16	2-7/16	3-5/8	10	01157 23	3,374
7/32	5,56	2-1/2	3-3/4	10	01157 24	4,037
15/64	5,95	2-5/8	3-7/8	10	01157 25	4,037
1/4	6,35	2-3/4	4"	10	01157 26	5,372
17/64	6,75	2-7/8	4-1/8	10	01157 27	6,810
9/32	7,14	2-15/16	4-1/4	5	01157 28	6,986

d	d	l <sub>2</sub>	l <sub>1</sub>		cod.	€
inch	mm	inch	inch			cad/each
19/64	7,54	3-1/16	4-3/8	5	01157 29	7,255
5/16	7,94	3-3/16	4-1/2	5	01157 30	7,783
21/64	8,33	3-5/16	4-5/8	5	01157 31	8,321
11/32	8,73	3-7/16	4-3/4	5	01157 32	10,019
23/64	9,13	3-1/2	4-7/8	5	01157 33	10,184
3/8	9,52	3-5/8	5"	5	01157 34	11,364
25/64	9,92	3-3/4	5-1/8	5	01157 35	11,903
13/32	10,32	3-7/8	5-1/4	5	01157 36	15,008
27/64	10,72	3-15/16	5-3/8	5	01157 37	17,543
7/16	11,11	4-1/16	5-1/2	5	01157 38	18,340
29/64	11,51	4-3/16	5-5/8	5	01157 39	18,340
15/32	11,91	4-5/16	5-3/4	5	01157 40	20,400
31/64	12,30	4-7/16	5-7/8	5	01157 41	22,263
1/2	12,70	4-1/2	6"	5	01157 42	22,667

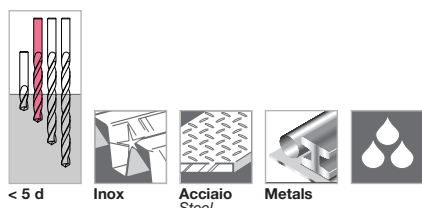

**Velocità di taglio consigliata / Recommended cutting speed**  
**Acciaio / Steel - 12 m/min**  
**Inox - 6 m/min**



Rendimenti elevati e maggiore durata dei taglienti nella foratura degli acciai legati, nelle ghise e nei metalli in genere.  
 High level of performances in cutting alloy steel, cast iron, metals up to  $R \leq 900 \text{ N/mm}^2$  / Pour percer métaux et acier allié avec  $R \leq 900 \text{ N/mm}^2$  / Para taladrar acero aleado con elevada velocidad de corte  $R \leq 900 \text{ N/mm}^2$  / Einsatz in Stahl und Stahlguss, legiert und unlegiert bis zu einer Zug-Festigkeit von  $R \leq 900 \text{ N/mm}^2$ , Temperguss, Sintereisen, Aluminium legiert und unlegiert, Kupfer, Bronze.

21 pcs - Ø 1/16÷3/8 x 1/64  
**01159401** € 83,959  
 29 pcs - Ø 1/16÷1/2 x 1/64  
**01159402** € 210,457

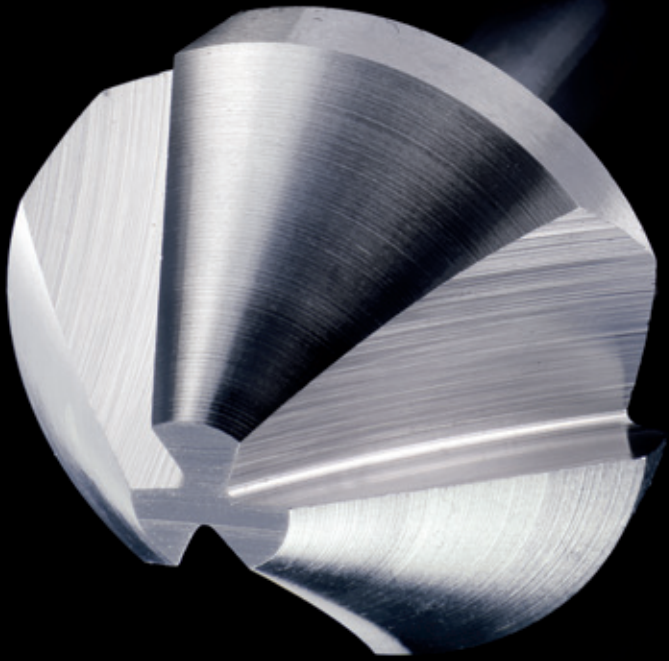

## > SVASATORI

Deburrin tools  
Fraise ba4urer  
Fresas de a4ellanar  
Ke elsen er

Gli utensili a svasare, che seguono l'operazione di foratura, sono fondamentali per le successive lavorazioni di filettatura con maschi a macchina e a mano. Sono costruiti in acciaio HSS-M2, al cobalto 5% AISI M35, con rivestimenti TiN e TiAlN, nelle varie forme a 90° - 75° - 60°.

## CUTTING TOOLS ENGINEERING

Countersink tools, which follow the drilling operations, are fundamental for the subsequent threading processes with machine and manual tappers. They are made of HSS-M2 steel, 5% AISI M35 cobalt, with TiN and TiAlN coating, in various formats of 90° - 75° - 60°.

Les outils à ébavurer qui suivent l'opération de perçage sont essentiels pour les usinages successifs de filetage avec des tarauds à machine et à la main. Ils sont fabriqués en acier HSS-M2, au cobalt 5% AISI M35, avec revêtements TiN et TiAlN, sous diverses formes à 90°-75°-60°.

Los utensilios para avellanar, que sufren la operación de perforado, son fundamentales para los sucesivos trabajos de fileteado con machos a máquina y a mano. Están hechos de acero HSS-M2, al cobalto 5% AISI M35, con revestimientos TiN y TiAlN, en las diferentes formas a 90° - 75° - 60°.

Die Senkwerkzeuge, die die Bohrvorgänge ausführen, sind für die nachfolgenden Gewindebearbeitungen mit Maschinen- und Handgewindebohrern grundlegend. Sie sind aus HSS-Stahl mit 5% Cobalt-Anteil AISI M35 mit TiN- und TiAlN-Beschichtungen in den verschiedenen Formen von 90° - 75° - 60° gebaut.



## 01185

### Frese ad incassare e svasare a 3 tagli

Deburring tools with 3 flutes / Fraise conique à ébavurer avec 3 coupes  
Fresas de avellanar con 3 cortes / Kegelsenker mit 3 Schneiden

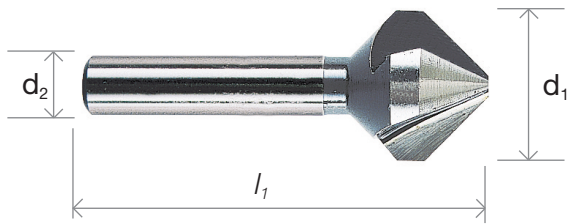
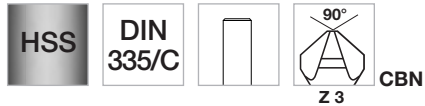

Per VITI For screws						
d <sub>1</sub>	d <sub>2</sub>	l <sub>1</sub>	DIN 74 AF ⊖	DIN 74 BF ⊙	cod.	€ cad/each
4,3	4	40			011850430	10,640
5	4	40	M 2,5		011850500	10,640
5,3	4	40			011850530	10,640
5,8	5	45			011850580	10,971
6	5	45	M 3		011850600	10,971
6,3	5	45		M 3	011850630	10,971
7	6	50	M 3,5		011850700	12,161
7,3	6	50			011850730	12,161
8	6	50	M 4		011850800	12,441
8,3	6	50		M 4	011850830	12,441
9,4	6	50			011850940	13,641
10	6	50	M 5		011851000	14,987
10,4	6	50		M 5	011851040	14,987
11,5	8	56	M 6		011851150	16,177

Per VITI For screws						
d <sub>1</sub>	d <sub>2</sub>	l <sub>1</sub>	DIN 74 AF ⊖	DIN 74 BF ⊙	cod.	€ cad/each
12,4	8	56		M 6	011851240	16,177
13,4	8	56	M 8		011851340	18,961
15	10	60			011851500	18,961
16,5	10	60	M 10	M 8	011851650	19,810
19	10	63			011851900	27,262
20,5	10	63	M 12	M 10	011852050	27,262
23	10	67			011852300	41,866
25	10	67	M 14	M 12	011852500	41,866
26	12	67			011852600	54,306
28	12	71	M 16	M 14	011852800	54,306
30	12	71			011853000	57,650
31	12	71		M 16	011853100	57,650
40	15	80			011854000	142,064

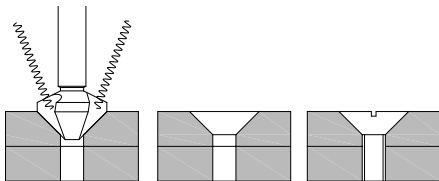

Viti DIN 74 AF: testa con intaglio - slotted screw

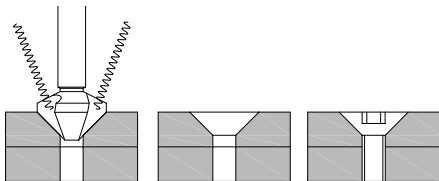

Viti DIN 74 BF: testa con esagono incassato - recessed hex head screw

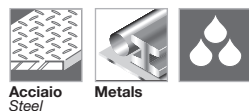

**Velocità di taglio consigliata / Recommended cutting speed**  
Acciaio / Steel - 10 m/min



Abs

6 pcs - Ø 6,3-8,3-10,4-12,4-16,5-20,5  
01270107 € 100,747

L'affilatura della svasatore è realizzata con la mola di rettifica al nitruro di boro cubico. The deburring tool sharpening is made by CBN grinding machine. / L'affûtage de la fraise à ébavurer est réalisé à la meule rectifieuse au nitruro de bore cubique. / El afilado del utensilio desbarbador se realiza con la máquina para rectificación al nitruro de boro cúbico. / Der Schliff des Senkers wurde mit einer Nitrid-Schleifscheibe mit kubischem Bornitrid hergestellt.

# 01260

## Frese ad incassare e svasare a 3 tagli

Deburring tools with 3 flutes / Fraise conique à ébavurer avec 3 coupes  
Fresas de avellanar con 3 cortes / Kegelsenker mit 3 Schneiden

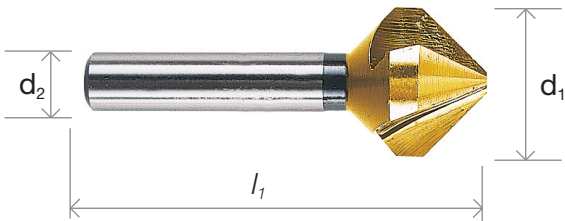
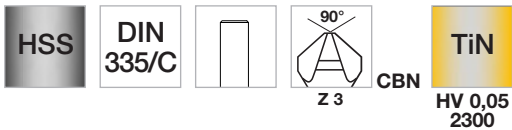

d <sub>1</sub>	d <sub>2</sub>	l <sub>1</sub>	Per VITI For screws		cod.	€ cad/each
			DIN 74 AF ⊖	DIN 74 BF ⊕		
4,3	4	40			012600430	17,316
5	4	40	M 2,5		012600500	17,316
5,3	4	40			012600530	17,316
5,8	5	45			012600580	17,554
6	5	45	M 3		012600600	17,554
6,3	5	45		M 3	012600630	17,926
7	6	50	M 3,5		012600700	19,220
7,3	6	50			012600730	19,220
8	6	50	M 4		012600800	19,593
8,3	6	50		M 4	012600830	19,593
9,4	6	50			012600940	21,011
10	6	50	M 5		012601000	24,747
10,4	6	50		M 5	012601040	24,747
11,5	8	56	M 6		012601150	26,237

d <sub>1</sub>	d <sub>2</sub>	l <sub>1</sub>	Per VITI For screws		cod.	€ cad/each
			DIN 74 AF ⊖	DIN 74 BF ⊕		
12,4	8	56		M 6	012601240	26,237
13,4	8	56	M 8		012601340	28,638
15	10	60			012601500	29,021
16,5	10	60	M 10	M 8	012601650	32,458
19	10	63			012601900	43,242
20,5	10	63	M 12	M 10	012602050	44,826
23	10	67			012602300	70,525
25	10	67	M 14	M 12	012602500	68,289
26	12	67			012602600	81,724
28	12	71	M 16	M 14	012602800	85,077
30	12	71			012603000	87,323
31	12	71		M 16	012603100	89,559
40	13	80			012604000	217,174

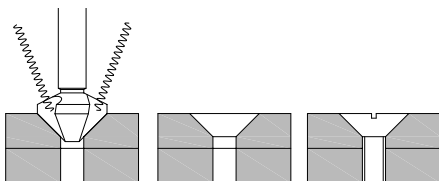

Viti DIN 74 AF: testa con intaglio - slotted screw

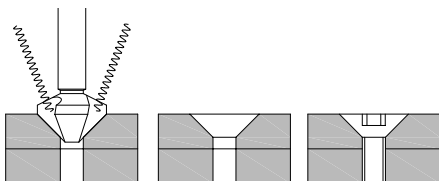

Viti DIN 74 BF: testa con esagono incassato - recessed hex head screw

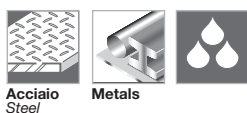

**Velocità di taglio consigliata / Recommended cutting speed**  
Acciaio / Steel - 14 m/min



6 pcs - Ø 6,3-8,3-10,4-12,4-16,5-20,5  
**01270109 € 151,131**

L'affilatura della svasatore è realizzata con la mola di rettifica al nitrato di boro cubico. The deburring tool sharpening is made by CBN grinding machine. / L'affûtage de la fraise à ébavurer est réalisé à la meule rectifieuse au nitrure de bore cubique. / El afilado del utensilio desbarbador se realiza con la máquina para rectificación al nitrato de boro cúbico. / Der Schliff des Senkers wurde mit einer Nitrid-Schleifscheibe mit kubischem Bornitrid hergestellt.

## 01261

### Frese ad incassare e svasare a 3 tagli

Deburring tools with 3 flutes / Fraise conique à ébavurer avec 3 coupes  
Fresas de avellanar con 3 cortes / Kegelsenker mit 3 Schneiden

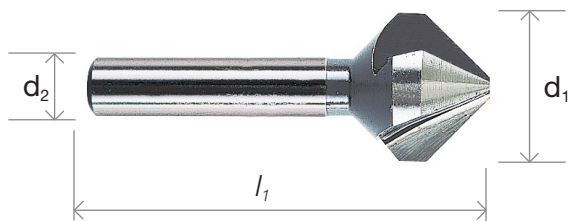
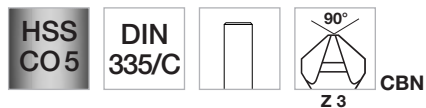

Per VITI  
For screws

d <sub>1</sub>	d <sub>2</sub>	l <sub>1</sub>	DIN 74 AF ⊖	DIN 74 BF ⊕	cod.	€ cad/each
6,3	5	45		M 3	012610630	14,231
8,3	6	50		M 4	012610830	16,032
10,4	6	50		M 5	012611040	23,008
12,4	8	56		M 6	012611240	25,740
15	10	60	M 8		012611500	29,487
16,5	10	60		M 8	012611650	31,650
20,5	10	63		M 10	012612050	43,936
25	10	67		M 12	012612500	66,333
31	12	71		M 16	012613100	91,794

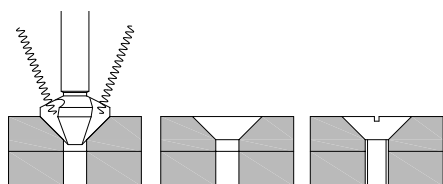

Viti DIN 74 AF: testa con intaglio - slotted screw

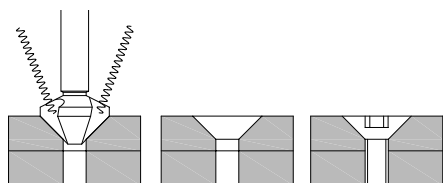

Viti DIN 74 BF: testa con esagono incassato - recessed hex head screw

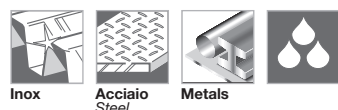

**Velocità di taglio consigliata / Recommended cutting speed**  
Acciaio / Steel - 12 m/min - Inox - 6 m/min



6 pcs - Ø 6,3-8,3-10,4-12,4-16,5-20,5  
01270110 € 134,550

L'affilatura della svasatore è realizzata con la mola di rettifica al nitruro di boro cubico. The deburring tool sharpening is made by CBN grinding machine. / L'affûtage de la fraise à ébavurer est réalisé à la meule rectifieuse au nitrure de bore cubique. / El afilado del utensilio desbarbador se realiza con la máquina para rectificación al nitruro de boro cúbico. / Der Schliff des Senkers wurde mit einer Nitrid-Schleifscheibe mit kubischem Bornitrid hergestellt.

# 01262

## Frese ad incassare e svasare a 3 tagli

Deburring tools with 3 flutes / Fraise conique à ébavurer avec 3 coupes

Fresas de avellanar con 3 cortes / Kegelsenker mit 3 Schneiden

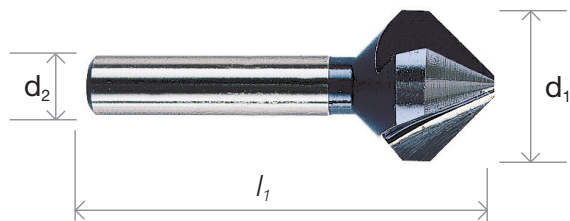
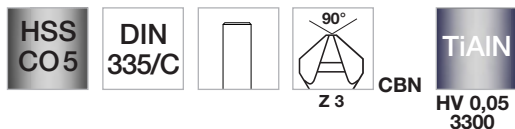

Per VITI  
For screws

d <sub>1</sub>	d <sub>2</sub>	l <sub>1</sub>	DIN 74 AF ⊖	DIN 74 BF ⊙	cod.	€ cad/each
6,3	5	45		M 3	012620630	19,665
8,3	6	50		M 4	012620830	26,641
10,4	6	50		M 5	012621040	39,020
12,4	8	56		M 6	012621240	48,438
15	10	60	M 8		012621500	53,147
16,5	10	60		M 8	012621650	57,857
20,5	10	63		M 10	012622050	79,385
25	10	67		M 12	012622500	121,095
31	12	71		M 16	012623100	143,969

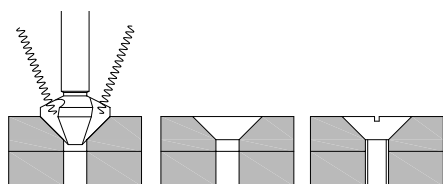

Viti DIN 74 AF: testa con intaglio - slotted screw

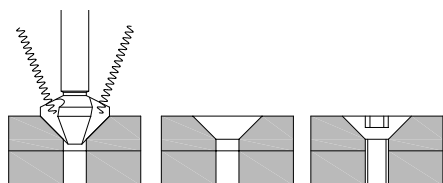

Viti DIN 74 BF: testa con esagono incassato - recessed hex head screw



**Velocità di taglio consigliata / Recommended cutting speed**  
Acciaio / Steel - 16 m/min - Inox - 9 m/min



6 pcs - Ø 6,3-8,3-10,4-12,4-16,5-20,5  
01270111 € 205,965

L'affilatura della svasatore è realizzata con la mola di rettifica al nitruro di boro cubico. The deburring tool sharpening is made by CBN grinding machine. / L'affûtage de la fraise à ébavurer est réalisé à la meule rectifieuse au nitrure de bore cubique. / El afilado del utensilio desbarbador se realiza con la máquina para rectificación al nitruro de boro cúbico. / Der Schliff des Senkers wurde mit einer Nitrid-Schleifscheibe mit kubischem Bornitrid hergestellt.

## 01263

### Frese ad incassare e svasare a 3 tagli in Metallo Duro

Carbide deburring tools with 3 flutes / Fraise conique à ébavurer carbure avec 3 coupes

Fresas de avellanar metal duro con 3 cortes / Kegelsenker VHM mit 3 Schneiden



## METALLO DURO/CARBIDE

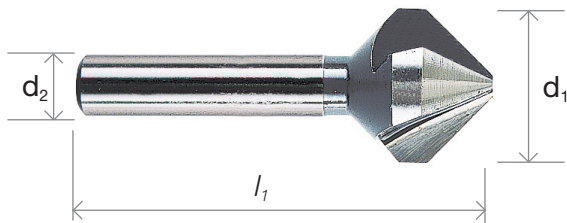

d <sub>1</sub>	d <sub>2</sub>	l <sub>1</sub>	Per VITI For screws DIN 74 BF	cod.	€ cad/each
6,3	6	50	M 3	012630630	88,700
8,3	6	50	M 4	012630830	97,011
10,4	6	50	M 5	012631040	99,784
12,4	8	50	M 6	012631240	110,869
16,5	10	60	M 8	012631650	160,756
20,5	10	63	M 10	012632050	255,003
25	10	67	M 12	012632500	360,325

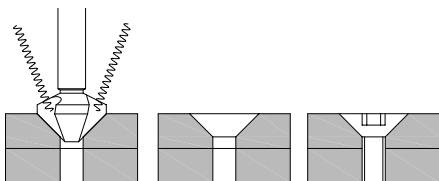

Viti DIN 74 BF: testa con esagono incassato - recessed hex head screw

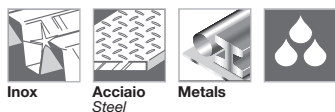

**Velocità di taglio consigliata / Recommended cutting speed**  
**Acciaio / Steel - 60 m/min - Inox - 30 m/min**

Gli svasatori in metallo duro sono affilati con utensili diamantati. Sono prodotti ottimi nelle lavorazioni di materiali molto duri e abrasivi, quali acciai temprati, acciai duri, acciai al manganese, polimeri rinforzati con fibre abrasive. Carbide deburring tools are sharpened through diamond blades. They're able to work into very hard and abrasive materials, such as hard steel, Mn steel, reinforced polymers with abrasive fibers. / Les fraises à ébavurer en métal dur sont aiguisées à l'aide d'outils diamantés. Ce sont d'excellents produits pour l'usinage de matériaux très durs et abrasifs tels que les aciers trempés, les aciers durs, les aciers au manganèse, les polymères renforcés de fibres abrasives. / Los desbarbadores de metal duro se afilan con utensilios diamantados. Son productos óptimos para trabajar materiales muy duros y abrasivos, como aceros templados, aceros duros, aceros al manganesio, polímeros reforzados con fibras abrasivas. / Die Senker aus Hartmetall wurden mit Diamantwerkzeugen geschliffen. Es sind hervorragende Produkte für die Bearbeitung von sehr harten und abrasiven Materialien, wie gehärtete Stähle, Hartstähle, Manganstähle, mit abrasiven Fasern verstärkte Polymere.

# 01264

## Frese ad incassare e svasare a 3 tagli in Metallo Duro

Carbide deburring tools with 3 flutes / Fraise conique à ébavurer carbure avec 3 coupes

Fresas de avellanar metal duro con 3 cortes / Kegelsenker VHM mit 3 Schneiden

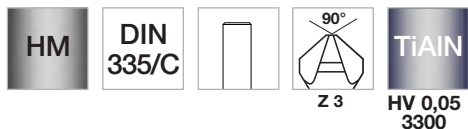

### METALLO DURO/CARBIDE

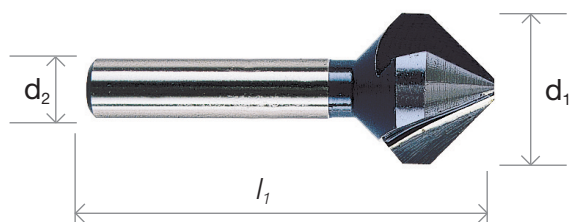

$d_1$	$d_2$	$l_1$	Per VITI For screws DIN 74 BF	cod.	€ cad/each
6,3	6	50	M 3	012640630	98,387
8,3	6	50	M 4	012640830	106,698
10,4	6	50	M 5	012641040	114,585
12,4	8	50	M 6	012641240	125,670
16,5	10	60	M 8	012641650	179,190
20,5	10	63	M 10	012642050	280,226
25	10	67	M 12	012642500	399,686

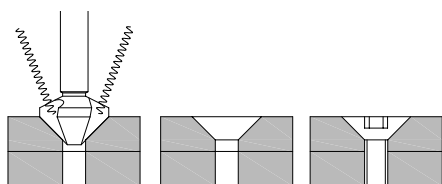

Viti DIN 74 BF: testa con esagono incassato - recessed hex head screw

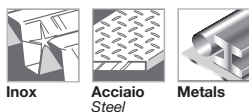

**Velocità di taglio consigliata / Recommended cutting speed**  
**Acciaio / Steel - 60 m/min - Inox - 30 m/min**

Gli svasatori in metallo duro sono affilati con utensili diamantati. Sono prodotti ottimi nelle lavorazioni di materiali molto duri e abrasivi, quali acciai temprati, acciai duri, acciai al manganese, polimeri rinforzati con fibre abrasive. Carbide deburring tools are sharpened through diamond blades. They're able to work into very hard and abrasive materials, such as hard steel, Mn steel, reinforced polymers with abrasive fibers. / Les fraises à ébavurer en métal dur sont aiguisées à l'aide d'outils diamantés. Ce sont d'excellents produits pour l'usinage de matériaux très durs et abrasifs tels que les aciers trempés, les aciers durs, les aciers au manganèse, les polymères renforcés de fibres abrasives. / Los desbarbadores de metal duro se afilan con utensilios diamantados. Son productos óptimos para trabajar materiales muy duros y abrasivos, como aceros templados, aceros duros, aceros al manganesio, polímeros reforzados con fibras abrasivas. / Die Senker aus Hartmetall wurden mit Diamantwerkzeugen geschliffen. Es sind hervorragende Produkte für die Bearbeitung von sehr harten und abrasiven Materialien, wie gehärtete Stähle, Hartstähle, Manganstähle, mit abrasiven Fasern verstärkte Polymere.

## 19001

### Svasatori a 90° con attacco esagonale 1/4"

90° countersink with 1/4" hexagon shank / Fraise conique a 90° avec 6 pans de 1/4"

Avellanador a 90° con mango esagonal 1/4" / Kagelsenker-bits 90°, mit 1/4" sechskant-Aufnahme

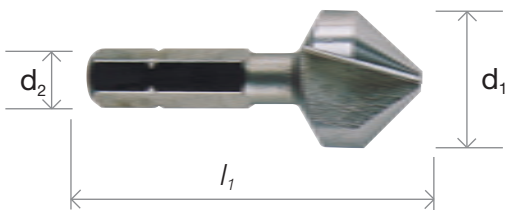

$d_1$	$l_1$	$d_2$ Hex	Per VITI For screws DIN 74 BF	cod.	€ cad/each
6,3	40	1/4	M 3	19001063	13,341
8,3	45	1/4	M 4	19001083	13,341
10,4	47	1/4	M 5	19001104	14,293
12,4	49	1/4	M 6	19001124	15,256
16,5	52	1/4	M 8	19001165	17,150
20,5	55	1/4	M 10	19001205	22,253

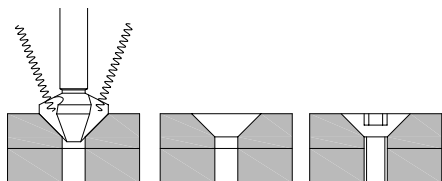

Viti DIN 74 BF: testa con esagono incassato - recessed hex head screw

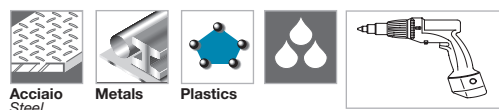

**Velocità di taglio consigliata /**  
Recommended cutting speed  
**Acciaio / Steel - 10 m/min**  
**Plastiche / Plastics - 10 m/min**



6 pcs - Ø 6,3-8,3-10,4-12,4-16,5-20,5  
19020214 € 132,087

L'affilatura della svasatore è realizzata con la mola di rettifica al nitruro di boro cubico. The deburring tool sharpening is made by CBN grinding machine. / L'affûtage de la fraise à ébavurer est réalisé à la meule rectifieuse au nitruro de bore cubique. / El afilado del utensilio desbarbador se realiza con la máquina para rectificación al nitruro de boro cúbico. / Der Schliff des Senkers wurde mit einer Nitrid-Schleifscheibe mit kubischem Bornitrid hergestellt.

# 19003

## Svasatori a 90° con attacco rapido esagonale 1/4"

90° countersink with 1/4" hexagon shank / Fraise conique a 90° avec 6 pans de 1/4"

Avellanador a 90° con mango esagonal 1/4" / Kagelsenker-bits 90°, mit 1/4" sechskant-Aufnahme

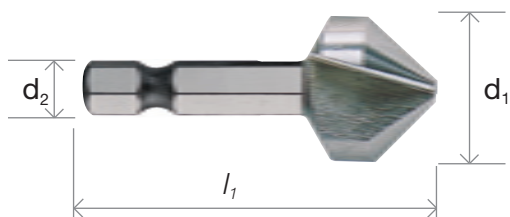
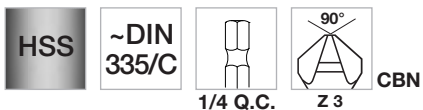

$d_1$	$l_1$	$d_2$ 	Per VITI For screws DIN 74 BF	cod.	€ cad/each
6,3	40	1/4	M 3	190030630	9,149
8,3	45	1/4	M 4	190030830	10,485
10,4	47	1/4	M 5	190031040	12,472
12,4	49	1/4	M 6	190031240	15,266
16,5	52	1/4	M 8	190031650	19,458
20,5	55	1/4	M 10	190032050	26,910

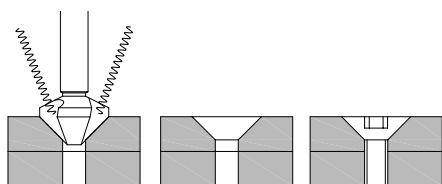

Viti DIN 74 BF: testa con esagono incassato - recessed hex head screw



**Velocità di taglio consigliata / Recommended cutting speed**  
**Acciaio / Steel - 10 m/min - Plastiche / Plastics - 10 m/min**

L'affilatura della svasatore è realizzata con la mola di rettifica al nitruro di boro cubico. The deburring tool sharpening is made by CBN grinding machine.  
 L'affûtage de la fraise à ébavurer est réalisé à la meule rectifieuse au nitruro de bore cubique. / El afilado del utensilio desbarbador se realiza con la máquina para rectificación al nitruro de boro cúbico. / Der Schliff des Senkers wurde mit einer Nitrid-Schleifscheibe mit kubischem Bornitrid hergestellt.



## 01193

### Frese ad incassare e svasare a 3 tagli, serie lunga

Deburring tools / Fraise conique à ébavurer

Fresas de avellanar / Kegelsenker

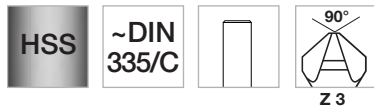

d <sub>1</sub>	d <sub>2</sub>	l <sub>1</sub>	cod.	€ cad/each
6,3	5	104	011930630	25,337
8,3	6	105	011930830	28,525
10,4	6	107	011931040	34,445
12,4	8	108	011931240	36,598
15	10	109	011931500	41,980
16,5	10	111	011931650	45,043
20,5	10	114	011932050	62,555
25	10	118	011932500	94,433

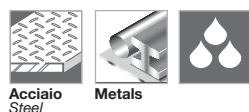
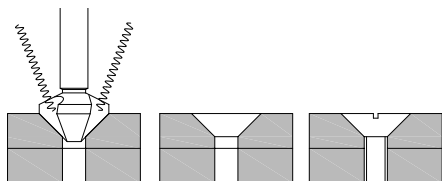

**Velocità di taglio consigliata / Recommended cutting speed**  
**Acciaio / Steel - 10 m/min**

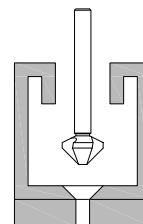

6 pcs - Ø 6,3-8,3-10,4-12,4-16,5-20,5  
**01270207 € 227,700**

Gli svasatori serie lunga, con gambo 100 mm, sono principalmente indicati nell'utilizzo di svasature su luoghi difficili da raggiungere, come pareti interne di profilati. Long serie deburring tools are suitable for cutting into hidden places, such as structural internal wall. / Les fraises à ébavurer série longue, avec une tige de 100 mm, sont principalement indiquées pour réaliser des ébavurages dans des endroits difficiles à atteindre, comme les murs à l'intérieur des profilés. / Los desbarbadores de la serie larga, con vástago de 100 mm, son indicados principalmente para usar desbarbados en lugares difíciles de alcanzar, como paredes internas de perfilados. / Die Senker der langen Serie mit einem Schaft von 100 mm sind hauptsächlich für die Verwendung von Senklöchern an schwer erreichbaren Stellen, wie Innenwände von Profilen, geeignet.

# 01196

## Frese ad incassare e svasare a 3 tagli, codolo conico Morse

Deburring tools / Fraise conique à ébavurer

Fresas de avellanar / Kegelsenker

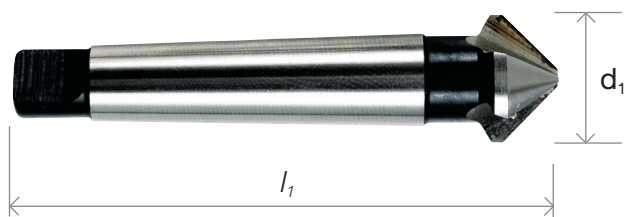
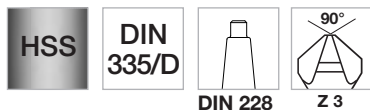

d <sub>1</sub>	MK	l <sub>1</sub>	Per VITI / For screws		cod.	€ cad/each
			DIN 74 AF ⊖	DIN 74 BF ⊙		
15	1	85	M 8		011961500	38,057
16,5	1	85		M 8	011961650	44,826
19	2	100	M 10		011961900	52,671
20,5	2	100		M 10	011962050	54,017
23	2	106	M 12		011962300	56,708
25	2	106		M 12	011962500	74,820
26	2	106	M 14		011962600	74,820
28	2	112		M 14	011962800	91,846
30	2	112	M 16		011963000	99,132
31	2	112		M 16	011963100	108,137
34	2	118	M 18	M 18	011963400	122,296
37	2	118	M 20	M 20	011963700	137,748
40	3	140			011964000	191,817
50	3	150			011965000	310,262

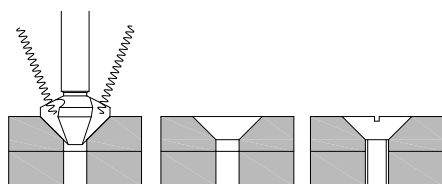

Viti DIN 74 AF: testa con intaglio - *slotted screw*

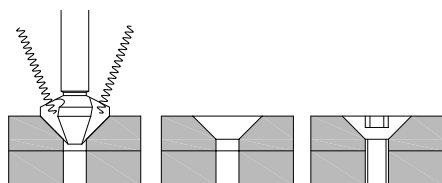

Viti DIN 74 BF: testa con esagono incassato - *recessed hex head screw*

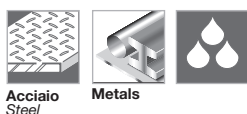

**Velocità di taglio consigliata / Recommended cutting speed**  
**Acciaio / Steel - 10 m/min**

Gli svasatori con attacco conico Morse trovano impiego su trapani a colonna nelle lavorazioni di acciai e metalli con R < 800 N/mm<sup>2</sup>. Morse taper shank deburring tools are used with stationary drilling machine to cut metals and all the materials with R < 800 N/mm<sup>2</sup>. / Les fraises coniques à ébavurer Morse peuvent être utilisées sur les perceuses à colonne lors des usinages des aciers et des métaux avec R < 800 N/mm<sup>2</sup>. / Los desbarbadores con empalme cónico Morse se utilizan en taladros de columna para trabajar el acero y los metales con R < 800 N/mm<sup>2</sup>. / Die Senker mit Morsekegel finden auf Säulenbohrmaschinen bei der Bearbeitung von Stählen und Metallen mit Zugfestigkeit < 800 N/mm<sup>2</sup> Anwendung.

## 01192

### Frese ad incassare e svasare a 1 tagliente

Deburring tools / Fraise conique à ébavurer

Fresas de avellanar / Kegelsenker

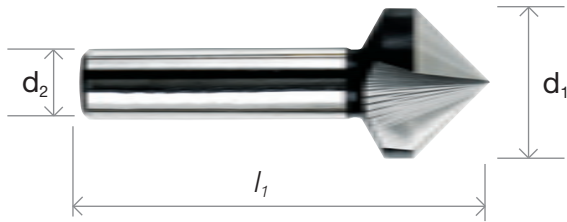
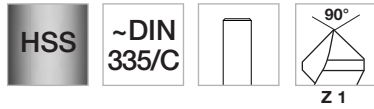

d <sub>1</sub>	d <sub>2</sub>	l <sub>1</sub>	cod.	€ cad/each
6	5	45	011920600	19,986
8	6	50	011920800	22,180
10	6	50	011921000	23,526
12	8	56	011921200	29,932
16	10	60	011921600	36,339
20	10	63	011922000	53,717
25	10	67	011922500	88,658
30	12	71	011923000	115,527

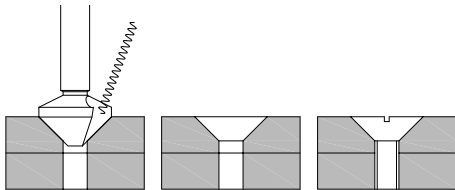

Metals



Plastics



**Velocità di taglio consigliata / Recommended cutting speed**  
**Plastica / Plastics - 10 m/min**

Speciale per alluminio, metalli leggeri e plastica. Lavora senza vibrazioni, ottima finitura. For aluminium, metals and plastics. For deburring and small chamfers. Best surface finish. Works with no vibrations. / Pour aluminium, métaux légers et plastiques. Pour ébavurage et petits chanfreirie. Meilleur état de surface. Travaille sans vibrations. / Especial para aluminio, metales ligeros y plástico. Trabaja sin vibraciones, óptimo acabado. / Für Aluminium, Metalle und Kunststoffe. Zum Entgraten und kleine Schrägkanten. Bestes Oberflächenfinish. Arbeitet ohne Vibrationen.

# 01186

## Frese ad incassare e svasare a 3 tagli

Deburring tools / Fraise conique à ébavurer

Fresas de avellanar / Kegelsenker

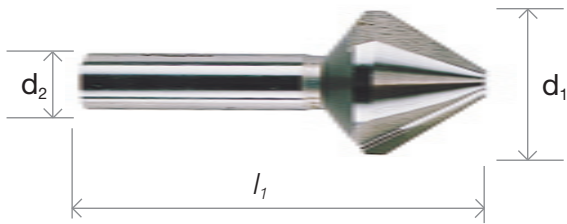

$d_1$	$d_2$	$l_1$	cod.	€ cad/each
6,3	5	45	011860630	14,293
8	6	50	011860800	17,595
10	6	53	011861000	19,458
12,5	8	56	011861250	25,875
16	10	63	011861600	25,875
20	10	67	011862000	35,304
25	10	71	011862500	53,313
31,5	12	76	011863150	73,661

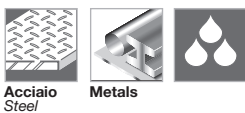
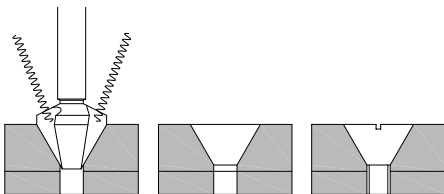

**Velocità di taglio consigliata / Recommended cutting speed**  
Acciaio / Steel - 10 m/min

## 01197

### Frese ad incassare e svasare in HSS

HSS deburring tools / Fraise conique à ébavurer en HSS

Fresas de avellanar HSS / Kegelsenker HSS

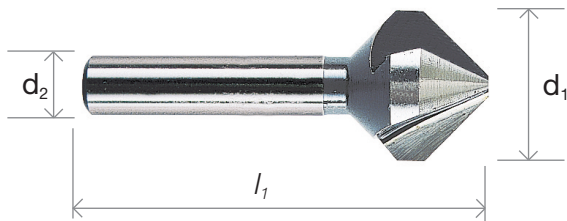

$d_1$	$d_2$	$l_1$	cod.	€ cad/each
6,3	5	45	011970630	16,353
8,3	6	50	011970830	18,320
10,4	6	50	011971040	22,253
12,4	8	56	011971240	23,598
13,4	8	56	011971340	28,980
16,5	10	63	011971650	28,980
20,5	10	67	011972050	40,365
25	10	71	011972500	61,065

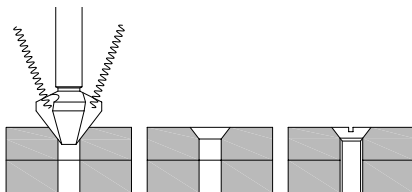

Acciaio  
Steel



Metals



Velocità di taglio consigliata / Recommended cutting speed  
Acciaio / Steel - 10 m/min

# 01188

## Frese a svasare e sbavare con foro 90°

90° countersinks / Fraise conique à ébavurer avec trous, 90° angle

Fresas de avellanar con orificio trasversal, angulo 90° / Kegelsenker 90° mit querloch

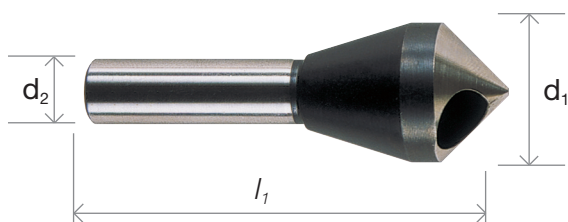

Gr.	d <sub>1</sub> min.-max	d <sub>2</sub>	l <sub>1</sub>	cod.	€ cad/each
1	2 ÷ 5	6	45	0118801	14,852
2	5 ÷ 10	8	48	0118802	18,744
3	10 ÷ 15	10	65	0118803	36,908
4	15 ÷ 20	12	85	0118804	65,402
5	20 ÷ 25	15	102	0118805	119,449
6	25 ÷ 30	15	115	0118806	176,095
7	30 ÷ 35	15	127	0118807	230,267
8	35 ÷ 40	15	136	0118808	323,862
9	40 ÷ 50	20	166	0118809	397,740

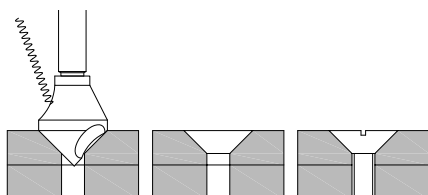

**Velocità di taglio consigliata / Recommended cutting speed**  
**Plastiche / Plastics - 10 m/min**  
**Leghe di alluminio - 30 m/min**



4 pcs - 2-5 5-10 10-15 15-20  
**01270108 € 135,450**

Speciale per alluminio, metalli leggeri e plastica. Lavora senza vibrazioni, ottima finitura. For aluminium, metals and plastics. For deburring and small chamfers. Best surface finish. Works with no vibrations. / Pour aluminium, métaux légers et plastiques. Pour ébavurage et petits chanfreinés. Meilleur état de surface. Travaille sans vibrations. / Especial para aluminio, metales ligeros y plástico. Trabaja sin vibraciones, óptimo acabado. / Für Aluminium, Metalle und Kunststoffe. Zum Entgraten und kleine Schrägkanten. Bestes Oberflächenfinish. Arbeitet ohne Vibrationen.

## 01273

### Svasatori con perno guida per sede viti a testa cilindrica

Flat countersinks with guide for through holes / Fraise à lamer pour têtes de vis  
 Avellanadores para asiento de tornillos / Flacksenker für Durchgangslöcher

HSS

DIN  
373



Grado fine - Per fori passanti  
 Fine grade - For through holes

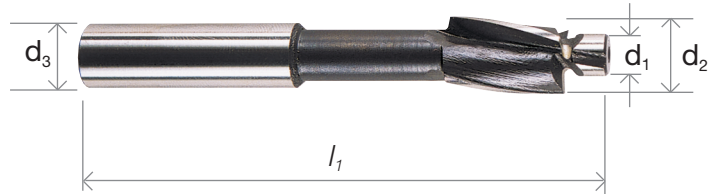

VITE thread	d <sub>2</sub>	d <sub>1</sub>	l <sub>1</sub>	d <sub>3</sub>	cod.	€ cad/each
M 3	6	3,2	71	5	0127303	17,854
4	8	4,3	71	5	0127304	17,854
5	10	5,3	80	8	0127305	17,854
6	11	6,4	80	8	0127306	18,527
8	15	8,4	100	12,5	0127308	29,777
10	18	10,5	100	12,5	0127310	35,739
12	20	13,0	100	12,5	0127312	39,040

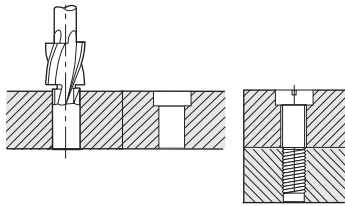

Velocità di taglio consigliata / Recommended cutting speed  
 Acciaio / Steel - 10 m/min  
 Leghe di alluminio - 30 m/min



6 pcs - M 3÷10  
 01275100 € 151,131

Svasatore idoneo a viteria e bulloneria di precisione. Deburring tool for precision nuts and bolts. /Fraise à ébavurer pour les vis et les boulons de précision. / Utensilio desbarbador idóneo para tornillos y pernos de precisión. / Senker für Präzisionsschrauben und -muttern.

# 01274

## Svasatori con perno guida per sede viti a testa cilindrica

Flat countersinks with guide for through holes / Fraise à lamer pour têtes de vis  
 Avellanadores para asiento de tornillos / Flacksenker für Durchgangslöcher

HSS

DIN  
373



Grado medio - Per fori passanti  
 Medium grade - For through holes

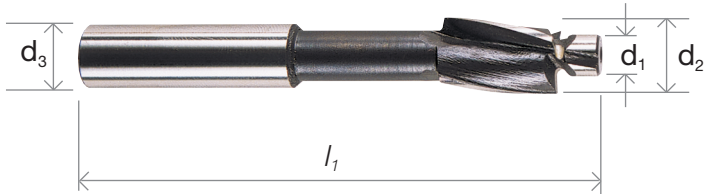

VITE thread	d <sub>2</sub>	d <sub>1</sub>	l <sub>1</sub>	d <sub>3</sub>	cod.	€ cad/each
M 3	6	3,4	71	5	0127403	17,854
4	8	4,5	71	5	0127404	17,854
5	10	5,5	80	8	0127405	17,854
6	11	6,6	80	8	0127406	18,527
8	15	9,0	100	12,5	0127408	29,777
10	18	11,0	100	12,5	0127410	35,739
12	20	14,0	100	12,5	0127412	39,040

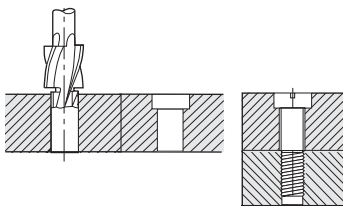

Velocità di taglio consigliata / Recommended cutting speed  
 Acciaio / Steel - 10 m/min  
 Leghe di alluminio - 30 m/min



6 pcs - M 3÷10  
 01275101 € 151,131

Svasatore idoneo a viteria e bulloneria standard. Deburring tool for standard nuts and bolts. / Fraise à ébavurer pour les vis et les boulons standard. / Utensilio desbarbador idóneo para tornillos y pernos estándar. / Senker für Standardschrauben und -muttern.



## 01272

### Svasatori con perno guida per sede viti a testa cilindrica

Flat countersinks with guide for through holes / Fraise à lamer pour têtes de vis  
 Avellanadores para asiento de tornillos / Flacksenker für Durchgangslöcher

HSS

DIN  
373



Per preforni di filettatura  
 For thread core holes

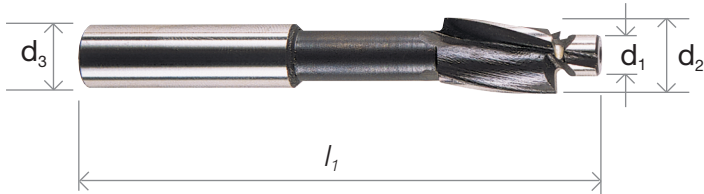

VITE thread	d <sub>2</sub>	d <sub>1</sub>	l <sub>1</sub>	d <sub>3</sub>	cod.	€ cad/each
M 3	6	2,5	71	5	0127203	17,854
4	8	3,3	71	5	0127204	17,854
5	10	4,2	80	8	0127205	17,854
6	11	5,0	80	8	0127206	18,527
8	15	6,8	100	12,5	0127208	29,777
10	18	8,5	100	12,5	0127210	35,739
12	20	10,2	100	12,5	0127212	39,040

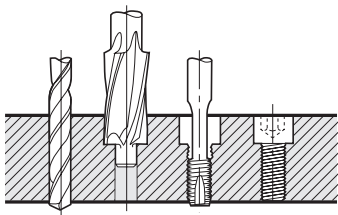

Velocità di taglio consigliata / Recommended cutting speed  
 Acciaio / Steel - 10 m/min  
 Leghe di alluminio - 30 m/min

Per preforni di filettature. For thread core holes / Pour trous de taraudage / Para orificios de roscado / Für Gewindelöcher



6 pcs - M 3÷10  
 01275105 € 151,131



## > UTENSILI CONICI

Conical drill bits  
Forets coniques  
Brocas conicas  
Blechsälbohrer

La lavorazione della lamiera, e di tutti i materiali in genere a spessore sottile, va assumendo sempre più importanza in tutte le attività industriali; l'acciaio inossidabile, inoltre, è oramai presente in gran parte delle costruzioni meccaniche. Pertanto, la gamma dei nostri utensili per il taglio della lamiera e di tutte le lavorazioni connesse è evoluta nelle nuove geometrie di taglio, nell'impiego di acciai superrapidi al cobalto e nei nuovi rivestimenti al nitrato di Titanio e al nitrato di Titanio-Alluminio, particolarmente adatti al taglio dei materiali molto duri, con ottimi rendimenti. Sono ora anche disponibili le famiglie complete delle punte-frese per rimuovere punti di saldatura, anche nelle esecuzioni con rivestimento al TiN. Si consiglia vivamente di seguire tutte le istruzioni indicate nel capitolo e nelle tabelle tecniche riportate in fondo al catalogo.

## 01182

Utensili conici integrali con scanalatura elicoidale e spoglia multipla per forare e allargare lamiere e tubi

Conical drill bits with spiral flute and multiple clearance for metal sheets and tubes / Forets coniques et étages avec affutage à multiples facettes pour travaillé la tole et les tubes / Brocas conicas y escalonadas con afilatura multipla para trabajar las planchas de metal y los tubos

HSS

Krino



CBN

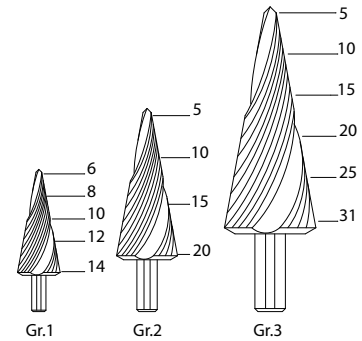
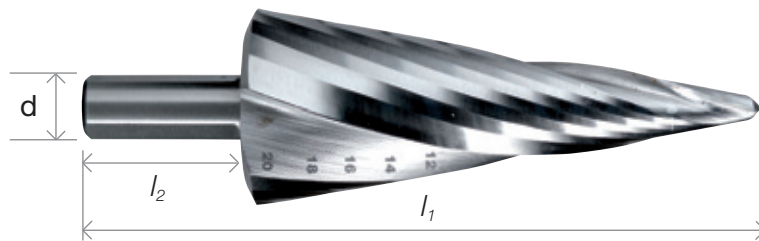

Gr.	Ø min.-max	d	l <sub>2</sub>	l <sub>1</sub>		cod.	€ cad/each
1	3 ÷ 14	6	25	60	1	0118201	24,757
2	6 ÷ 20	8	25	70	1	0118202	37,219
3	5 ÷ 31	10	25	105	1	0118203	80,026

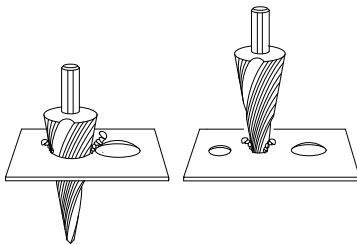

**Grande capacità di taglio, grande rendimento grazie alla nuova scanalatura a spirale e alla spoglia multipla. Usare una leggera pressione durante il taglio: l'elicoide è autoalimentante.**

*Better cutting performances due to the new spiral flute and multiple clearance. Please use a very soft press when drilling: the tool proceeds by itself.*

R ≤ 800 N/mm<sup>2</sup>



**Velocità di taglio consigliata / Recommended cutting speed**  
**Acciaio / Steel - 10 m/min - Leghe di alluminio - 30 m/min**  
**Plastiche / Plastics - 10 m/min**



Per forare lamiere in acciaio, tubi, profilati in acciaio e leghe leggere, plexiglass, plastica sino a 5 mm di spessore. For hole-making into metal sheets, pipes, structurals, light alloys sheets, plastics, plexiglass up to 5 mm thickness / Pour le perçage des trous dans tous matériaux de faible épaisseur (épaisseur max. 5 mm). / Broca-avellanador para cortar tubo y chapa de hierro y acero, aleaciones ligeras, plexiglass (5 mm de profundidad). / Zum Bohren größerer Löcher in dünnwandige Materialien oder zum Aufbohren bereits vorhandener Löcher.

3 pcs -  
 Gr.1 3÷14 mm  
 Gr.2 6÷20 mm  
 Gr.3 5÷31 mm  
**01182100**

€ 144,900

# 01180

## Utensili conici integrali per forare ed allargare lamiere e tubi

Conical drill bits for metal sheets and tubes / Forets coniques et étages pour la tôle / Brocas conicas para planchas / Blechsälbohrer

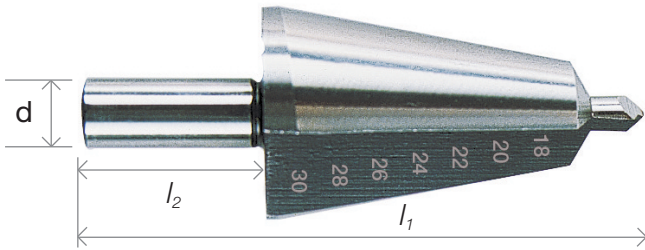

Gr.	Ø min.-max	d	l <sub>2</sub>	l <sub>1</sub>	cod.	€ cad/each
1	3 ÷ 14	6	21	58	0118001	18,113
2	6 ÷ 20	8	21	70	0118002	30,015
3	16 ÷ 30,5	10	25	79	0118003	51,543
4	26 ÷ 40	10	25	86	0118004	107,464
5	36 ÷ 50	13	25	90	0118005	165,683
6	40 ÷ 61	13	25	97	0118006	284,346
7	3 ÷ 31	10	21	109	0118007	77,242
8	3 ÷ 22,5	8	21	85	0118008	54,855

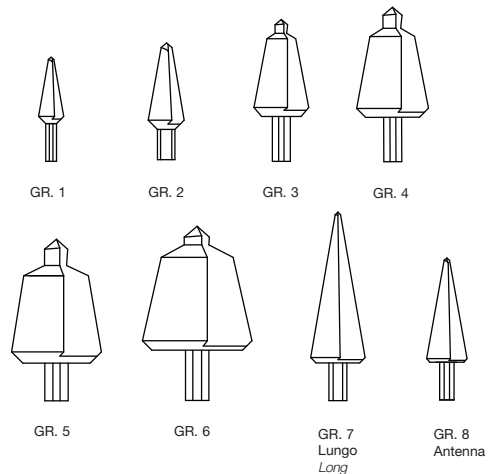

3 pcs -  
Gr.1 3÷14 mm  
Gr.2 6÷20 mm  
Gr.3 16÷30,5 mm  
01195101 € 124,200

# 01215

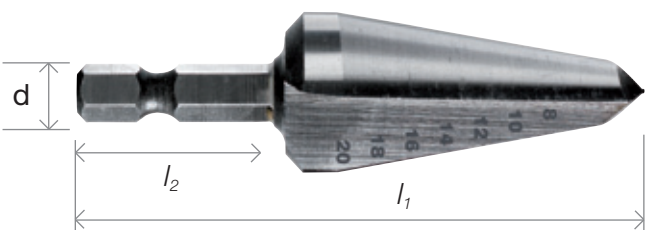

Gr.	Ø min.-max	d	l <sub>2</sub>	l <sub>1</sub>	cod.	€ cad/each
2	8 ÷ 20	1/4	20	68	0121502	31,050

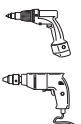

R ≤ 800 N/mm<sup>2</sup>



**Velocità di taglio consigliata**  
Recommended cutting speed  
**Acciaio / Steel - 10 m/min**  
**Leghe di alluminio - 30 m/min**  
**Plastiche / Plastics - 10 m/min**

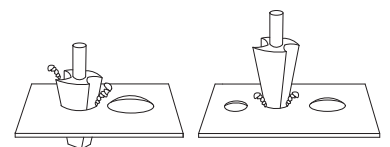

Per forare lamiere in acciaio, tubi, profilati in acciaio e leghe leggere, plexiglass, plastica sino a 5 mm di spessore.  
For hole-making into metal sheets, pipes, structurals, light alloys sheets, plastics, plexiglass up to 5 mm thickness /  
Pour le perçage des trous dans tous matériaux de faible épaisseur (épaisseur max. 5 mm). / Broca-avellanador para  
cortar tubo y chapa de hierro y acero, aleaciones ligeras, plexiglass (5 mm de profundidad). / Zum Bohren größerer  
Löcher in dünnwandige Materialien oder zum Aufbohren bereits vorhandener Löcher.

## 01200

### Utensili conici integrali per forare ed allargare lamiere e tubi

Conical drill bits for metal sheets and tubes / Forets coniques et étages pour la tôle

Brocas conicas para planchas / Blechsälbohrer

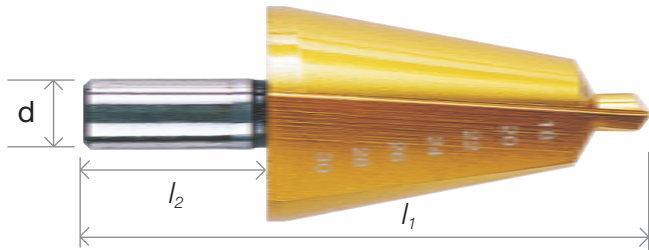
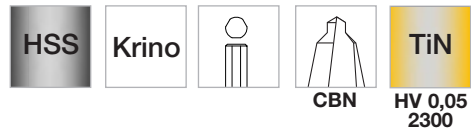

Gr.	Ø min.-max	d	l <sub>2</sub>	l <sub>1</sub>	cod.	€ cad/each
1	3 ÷ 14	6	21	58	0120001	28,980
2	6 ÷ 20	8	21	70	0120002	49,225
3	16 ÷ 30,5	10	25	79	0120003	94,030
4	26 ÷ 40	10	25	86	0120004	200,386
5	36 ÷ 50	13	25	90	0120005	287,699
6	40 ÷ 61	13	25	97	0120006	467,934
7	3 ÷ 31	10	21	109	0120007	145,531
8	3 ÷ 22,5	8	21	85	0120008	78,360

USO INTENSIVO  
INTENSIVE USE  
R≤1000 N/mm<sup>2</sup>

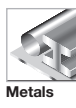

**Velocità di taglio consigliata /**  
Recommended cutting speed  
**Acciaio / Steel - 14 m/min**  
**Leghe di alluminio - 32 m/min**  
**Plastiche / Plastics - 14 m/min**



3 pcs -  
Gr.1 3÷14 mm  
Gr.2 6÷20 mm  
Gr.3 16÷30,5 mm

01195110

€ 173,518

Per forare lamiere in acciaio, tubi, profilati in acciaio e leghe leggere, plexiglass, plastica sino a 5 mm di spessore.  
For hole-making into metal sheets, pipes, structurals, light alloys sheets, plastics, plexiglass up to 5 mm thickness /  
Pour le perçage des trous dans tous matériaux de faible épaisseur (épaisseur max. 5 mm). / Broca-avellanador para  
cortar tubo y chapa de hierro y acero, aleaciones ligeras, plexiglass (5 mm de profundidad). / Zum Bohren größerer  
Löcher in dünnwandige Materialien oder zum Aufbohren bereits vorhandener Löcher.

# 01206

## Utensili conici integrali per forare ed allargare lamiere e tubi

Conical drill bits for metal sheets and tubes / Forets coniques et étages pour la tôle

Brocas conicas para planchas / Blechsälbohrer

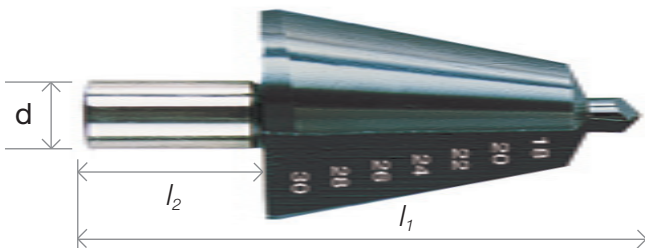
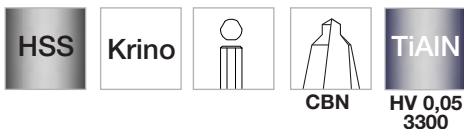

Gr.	Ø min.-max	d	l <sub>2</sub>	l <sub>1</sub>	cod.	€ cad/each
1	3 ÷ 14	6	21	58	0120601	33,451
2	6 ÷ 20	8	21	70	0120602	56,842
3	16 ÷ 30,5	10	25	79	0120603	114,181
4	26 ÷ 40	10	25	86	0120604	232,844
5	36 ÷ 50	13	25	90	0120605	329,120
6	40 ÷ 61	13	25	97	0120606	528,388
7	3 ÷ 31	10	21	109	0120607	169,036
8	3 ÷ 22,5	8	21	85	0120608	88,441

USO INTENSIVO  
INTENSIVE USE  
R<1200 N/mm<sup>2</sup>

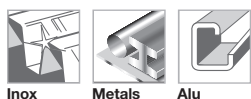

**Velocità di taglio consigliata /**  
Recommended cutting speed  
**Acciaio / Steel - 16 m/min - Leghe di alluminio - 34 m/min**  
**Plastiche / Plastics - 16 m/min**



Per forare lamiere in acciaio, tubi, profilati in acciaio e leghe leggere, plexiglass, plastica sino a 5 mm di spessore.  
For hole-making into metal sheets, pipes, structurals, light alloys sheets, plastics, plexiglass up to 5 mm thickness /  
Pour le perçage des trous dans tous matériaux de faible épaisseur (épaisseur max. 5 mm). / Broca-avellanador para  
cortar tubo y chapa de hierro y acero, aleaciones ligeras, plexiglass (5 mm de profundidad). / Zum Bohren größerer  
Löcher in dünnwandige Materialien oder zum Aufbohren bereits vorhandener Löcher.

3 pcs -  
Gr.1 3÷14 mm  
Gr.2 6÷20 mm  
Gr.3 16÷30,5 mm  
**01195111**

€ 195,905

## 01240

### Utensili conici a gradino con taglienti elicoidali ad altissimo rendimento

Spiral step drill bits / Forets étages hélicoïdaux

Brocas escalonadas helicoidales / Stufenbohrer mit Spiralnute

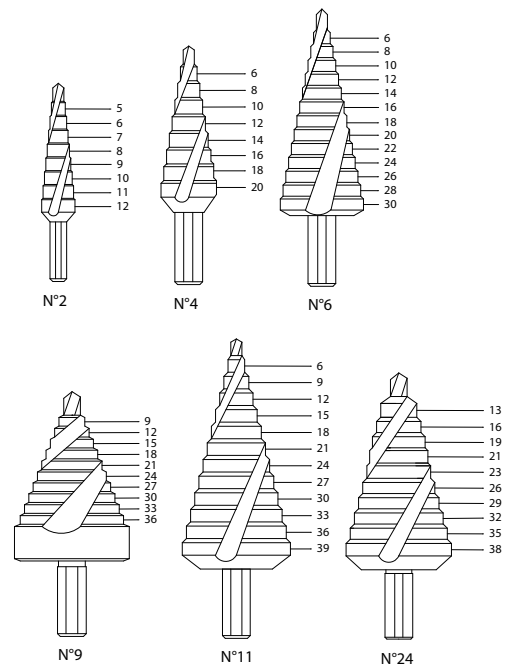
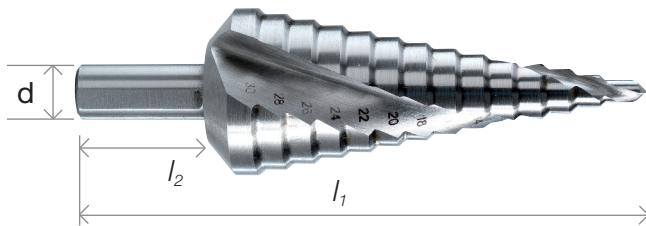

Gr.	Ø min.-max	Progressione Step	N° Gradini N° Steps	d	l <sub>2</sub>	l <sub>1</sub>	cod.	€ cad/each
2	4 ÷ 12	1	9	6	21	70	0124002	37,260
4	4 ÷ 20	2	9	10	25	85	0124004	46,575
6	4 ÷ 30	2	13	10	25	100	0124006	124,200
9	6 ÷ 36	3	10	10	25	80	0124009	151,110
11	4 ÷ 39	3	13	10	25	107	0124011	165,600
24	6 ÷ 38	-	11	10	25	96	0124024	167,670

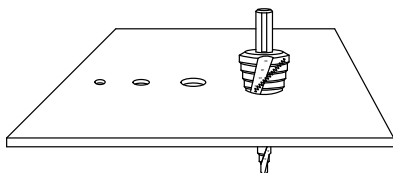

**Esercitare solo una lieve pressione durante il taglio. L'elicoide è autoalimentante grazie alla componente assiale della forza di taglio.**

*Please use a very soft press while drilling. The tool proceeds by itself, due to the axial cutting strength.*

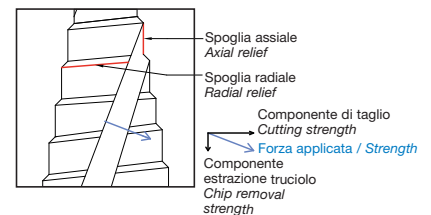

R ≤ 800 N/mm<sup>2</sup>

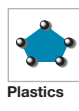
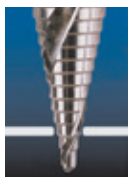

**Velocità di taglio consigliata / Recommended cutting speed**  
**Acciaio / Steel - 10 m/min**  
**Plastiche / Plastics - 10 m/min**



3 pcs -  
 Gr.2 4÷12 mm  
 Gr.4 4÷20 mm  
 Gr.6 4÷30 mm  
**01259107**

€ 171,334

Per forare lamiere in acciaio, tubi, profilati in acciaio e leghe leggere, plexiglass, plastica sino a 5 mm di spessore.  
 For hole-making into metal sheets, pipes, structurals, light alloys sheets, plastics, plexiglass up to 5 mm thickness /  
 Pour le perçage des trous dans tous matériaux de faible épaisseur (épaisseur max. 5 mm). / Broca-avellanador para  
 cortar tubo y chapa de hierro y acero, aleaciones ligeras, plexiglass (5 mm de profundidad). / Zum Bohren größerer  
 Löcher in dünnwandige Materialien oder zum Aufbohren bereits vorhandener Löcher.

# 01241

## Utensili a gradino con taglienti elicoidali ad alto rendimento con attacco 1/4" qc

Spiral step drill bits / Forets étages hélicoïdaux

Brocas escalonadas helicoidale / Stufenbohrer mit Spiralnute

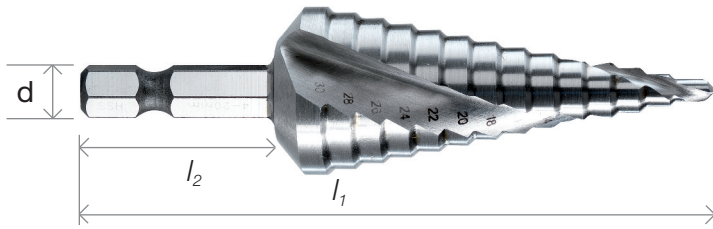

Gr.	Ø min.-max	Progressione Step	N° Gradini N° Steps	d	l <sub>2</sub>	l <sub>1</sub>	cod.	€ cad/each
4	4 ÷ 20	2	9	1/4	25	76	0124104	41,400
6	4 ÷ 30	2	13	1/4	25	100	0124106	111,780

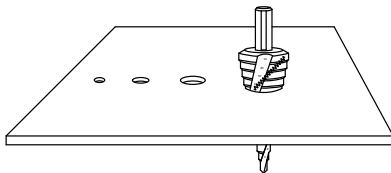

**Esercitare solo una lieve pressione durante il taglio. L'elicoide è autoalimentante grazie alla componente assiale della forza di taglio.**

*Please use a very soft press while drilling. The tool proceeds by itself, due to the axial cutting strength.*

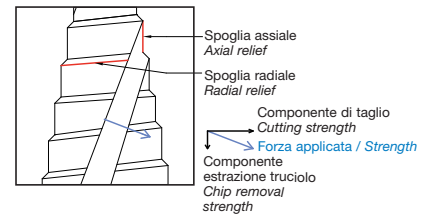

R ≤ 800 N/mm<sup>2</sup>

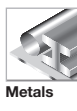
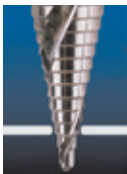

**Velocità di taglio consigliata / Recommended cutting speed**  
**Acciaio / Steel - 10 m/min**  
**Plastiche / Plastics - 10 m/min**

Per forare lamiere in acciaio, tubi, profilati in acciaio e leghe leggere, plexiglass, plastica sino a 5 mm di spessore. For hole-making into metal sheets, pipes, structurals, light alloys sheets, plastics, plexiglass up to 5 mm thickness / Pour le perçage des trous dans tous matériaux de faible épaisseur (épaisseur max. 5 mm). / Broca-avellanador para cortar tubo y chapa de hierro y acero, aleaciones ligeras, plexiglass (5 mm de profundidad). / Zum Bohren größerer Löcher in dünnwandige Materialien oder zum Aufbohren bereits vorhandener Löcher.



## 01244

### Utensili conici a gradino rivestiti al TiN con taglienti elicoidali ad altissimo rendimento

TiN and TiAIN spiral step drill bits / Forets étages hélicoïdaux au TiN et TiAIN

Brocas escalonadas helicoidale con recubrimiento de TiN y TiAIN / Stufenbohrer mit Spiralnute TiN und TiAIN

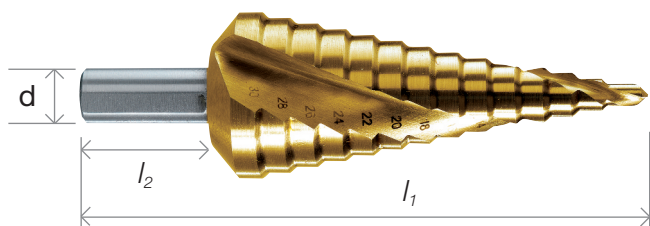
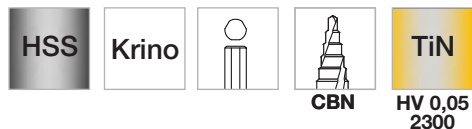

Gr.	Ø min.-max	Progressione Step	N° Gradini N° Steps	d	l <sub>2</sub>	l <sub>1</sub>	cod.	€ cad/each
2	4 ÷ 12	1	9	6	21	70	0124402	42,435
4	4 ÷ 20	2	9	10	25	85	0124404	68,310
6	4 ÷ 30	2	13	10	25	100	0124406	143,865
9	6 ÷ 36	3	10	10	25	80	0124409	217,350
11	4 ÷ 39	3	13	10	25	107	0124411	232,875
24	6 ÷ 38	-	11	10	25	96	0124424	240,120

R ≤ 800 N/mm<sup>2</sup>

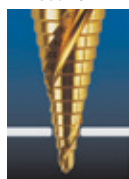

**Velocità di taglio consigliata /**  
Recommended cutting speed  
**Acciaio / Steel - 14 m/min**  
**Plastiche / Plastics - 14 m/min**



Per forare lamiere in acciaio, tubi, profilati in acciaio e leghe leggere, plexiglass, plastica sino a 5 mm di spessore.  
For hole-making into metal sheets, pipes, structurals, light alloys sheets, plastics, plexiglass up to 5 mm thickness /  
Pour le perçage des trous dans tous matériaux de faible épaisseur (épaisseur max. 5 mm). / Broca-avellanador para  
cortar tubo y chapa de hierro y acero, aleaciones ligeras, plexiglass (5 mm de profundidad). / Zum Bohren größerer  
Löcher in dünnwandige Materialien oder zum Aufbohren bereits vorhandener Löcher.

3 pcs -  
Gr.2 4÷12 mm  
Gr.4 4÷20 mm  
Gr.6 4÷30 mm  
**01259108**

€ 248,400

# 01248

## Utensili conici a gradino rivestiti al TiAlN con taglienti elicoidali ad altissimo rendimento

TiN and TiAlN spiral step drill bits / Forets étages hélicoïdaux au TiN et TiAlN

Brocas escalonadas helicoidales con recubrimiento de TiN y TiAlN / Stufenbohrer mit Spiralnute TiN und TiAlN

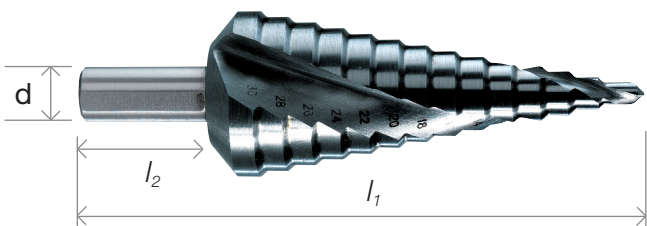
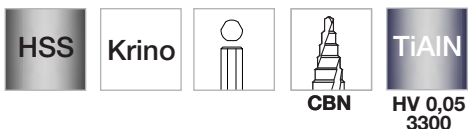

Gr.	Ø min.-max	Progressione Step	N° Gradini N° Steps	d	l <sub>2</sub>	l <sub>1</sub>	cod.	€ cad/each
2	4 ÷ 12	1	9	6	21	70	0124802	46,575
4	4 ÷ 20	2	9	10	25	85	0124804	76,590
6	4 ÷ 30	2	13	10	25	100	0124806	157,320
9	6 ÷ 36	3	10	10	25	80	0124809	240,120
11	4 ÷ 39	3	13	10	25	107	0124811	274,275
24	6 ÷ 38	-	11	10	25	96	0124824	253,575

R ≤ 800 N/mm<sup>2</sup>



**Velocità di taglio consigliata /**  
**Recommended cutting speed**  
**Acciaio / Steel - 16 m/min**  
**Plastiche / Plastics - 16 m/min**

Per forare lamiere in acciaio, tubi, profilati in acciaio e leghe leggere, plexiglass, plastica sino a 5 mm di spessore.  
 For hole-making into metal sheets, pipes, structurals, light alloys sheets, plastics, plexiglass up to 5 mm thickness /  
 Pour le perçage des trous dans tous matériaux de faible épaisseur (épaisseur max. 5 mm). / Broca-avellanador para  
 cortar tubo y chapa de hierro y acero, aleaciones ligeras, plexiglass (5 mm de profundidad). / Zum Bohren größerer  
 Löcher in dünnwandige Materialien oder zum Aufbohren bereits vorhandener Löcher.



3 pcs -  
 Gr.2 4÷12 mm  
 Gr.4 4÷20 mm  
 Gr.6 4÷30 mm  
**01259109**

€ 263,925

## 01183

### Utensili conici integrali a gradino per la foratura ed allargatura della lamiera

Step drill bits / Forets étages hélicoïdaux

Forets étages / Brocas escalonadas / Stufenbohrer

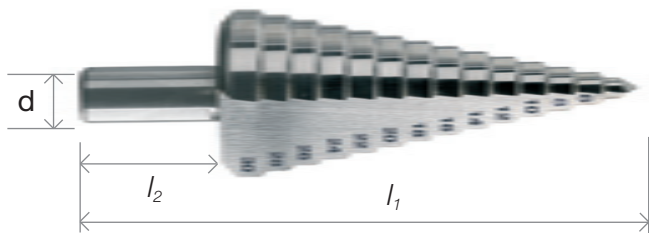

Gr.	Ø min.-max	Progressione Step	N° Gradini N° Steps	d	l <sub>2</sub>	l <sub>1</sub>	cod.	€ cad/each
<b>Metric - per costruzione - for construction</b>								
1	4 ÷ 12	2	5	6	21	56	0118301	24,188
2	4 ÷ 12	1	9	6	21	70	0118302	26,310
3	12 ÷ 20	1	9	10	25	85	0118303	67,886
4	4 ÷ 20	2	9	10	25	85	0118304	35,418
5	20 ÷ 30	1	11	10	25	97	0118305	107,412
6	4 ÷ 30	2	13	10	25	97	0118306	78,660
7	30 ÷ 40	1	11	13	21	97	0118307	156,337
8	40 ÷ 50	1	11	13	21	100	0118308	226,520
9	6 ÷ 36	3	10	10	25	80	0118309	143,575
*10	10 ÷ 58	3	12	13	25	90	0118310	363,709
11	4 ÷ 39	3	13	10	25	107	0118311	135,057



ABS

<b>01259102</b>	Gr.2	4÷12 mm
	Gr.4	4÷20 mm
	Gr.6	4÷30 mm
€ 156,720		
<b>01259105</b>	Gr.2	4÷12 mm
	Gr.3	12÷20 mm
	Gr.5	20÷30 mm
€ 161,460		

*Ricambio - Spare part	Ø	l <sub>1</sub>	d	cod.	€
	10	48		0118300	10,764

Pg	Ø	l <sub>1</sub>	d	cod.	€
21	6,3 ÷ 26,75	-	7	10 25 91	0118321 99,971
22	6 ÷ 30,5	-	7	10 25 80	0118322 89,331
23	6 ÷ 37	-	7	10 25 85	0118323 135,057
24	6 ÷ 38	-	11	10 25 96	0118324 124,428

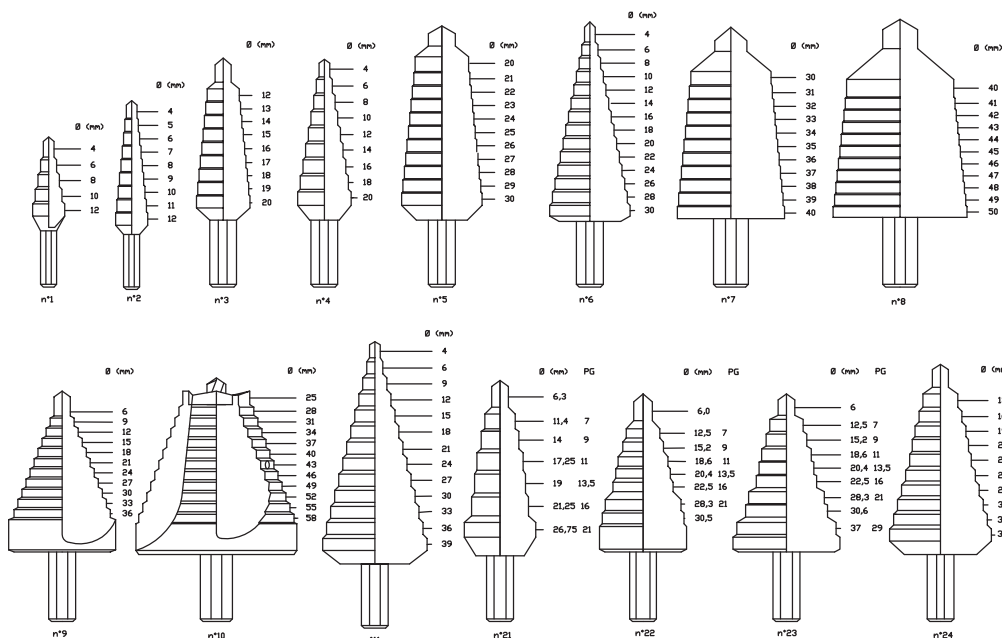

# 01239

## Utensili conici a gradino con attacco 1/4" per forare e allargare lamiere e tubi

Step drill bits, 1/4" shank / Forets étages avec queue 1/4"

Brocas escalonadas con mango 1/4" / Stufenbohrer

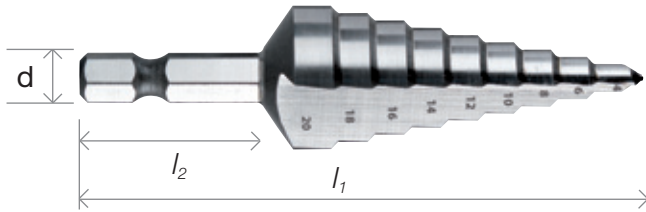

Gr.	Ø min.-max	Progressione Step	N° Gradini N° Steps	d Ø	l <sub>2</sub>	l <sub>1</sub>	cod.	€ cad/each
2	4 ÷ 12	1	9	1/4	25	68	0123902	27,842
4	4 ÷ 20	2	9	1/4	25	78	0123904	37,778
6	4 ÷ 30	2	13	1/4	25	101	0123906	83,835

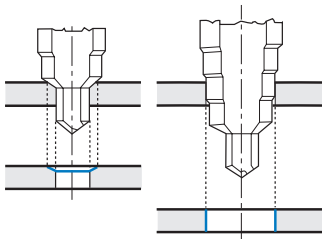

R ≤ 800 N/mm<sup>2</sup>

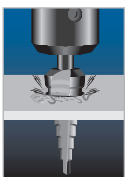

Acciaio  
Steel



Metals



Alu



Plastics



ABS

Per fori cilindrici e precisi in lamiere di acciaio, tubi, profilati, leghe leggere, plastica, plexiglass sino a 5 mm spessore. Taglio veloce, alto rendimento. For parallel and precise holes in metal sheets, pipes, structurals, light alloys, plastics, plexiglass up to 5 mm thickness. Fast cutting, high performance. / Perçage précise et haute rendement dans tous matériaux de faible épaisseur (max 5 mm). / Grande rendimiento y precision para cortar tubo y chapa de acero, aleaciones ligeras, plexiglass (5 mm profundidad). / Große Präzision und Leistung zum Bohren größerer Löcher in dünnwandige Materialien oder zum Aufbohren bereits vorhandener Löcher

3 pcs -  
Gr.2 4÷12 mm  
Gr.4 4÷20 mm  
Gr.6 4÷30 mm  
**01259118**

€ 162,102

## 01230

### Utensili conici a gradino rivestiti al TiN

TiN coated step drill bits / Forets étages revêtus au TiN

Brocas escalonadas con recubrimiento de TiN / Stufenbohrer TiN beschichtet

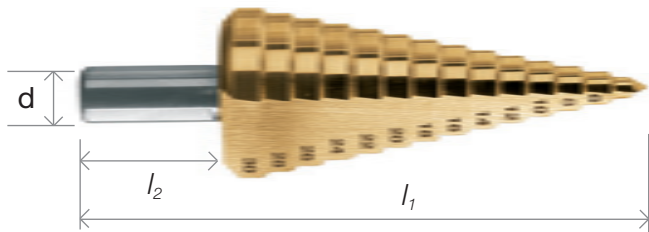
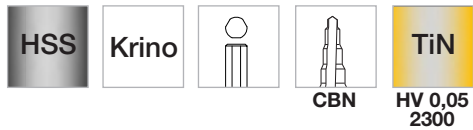

Gr.	Ø min.-max	Progressione Step	N° Gradini N° Steps	d	l <sub>2</sub>	l <sub>1</sub>	cod.	€ cad/each
-----	------------	-------------------	---------------------	---	----------------	----------------	------	------------

**Metric - per costruzione - for construction**

1	4 ÷ 12	2	5	6	21	56	0123001	44,319
2	4 ÷ 12	1	9	6	21	70	0123002	45,695
3	12 ÷ 20	1	9	10	25	85	0123003	115,309
4	4 ÷ 20	2	9	10	25	85	0123004	73,889
5	20 ÷ 30	1	11	10	25	97	0123005	198,140
6	4 ÷ 30	2	13	10	25	97	0123006	147,767
7	30 ÷ 40	1	11	13	21	97	0123007	282,100
8	40 ÷ 50	1	11	13	21	100	0123008	389,574
9	6 ÷ 36	3	10	10	25	80	0123009	236,208
10	10 ÷ 58	3	12	13	25	90	0123010	527,260
11	4 ÷ 39	3	13	10	25	107	0123011	237,326

**Pg**

21	6,3 ÷ 26,75	-	7	10	25	91	0123021	177,989
22	6 ÷ 30,5	-	7	10	25	80	0123022	137,696
23	6 ÷ 37	-	7	10	25	85	0123023	247,396
24	6 ÷ 38	-	11	10	25	96	0123024	236,208



**USO INTENSIVO**  
INTENSIVE USE  
R<1000 N/mm<sup>2</sup>

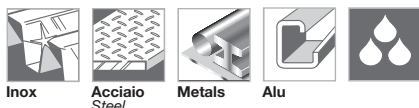

**Velocità di taglio consigliata /**  
Recommended cutting speed  
**Inox - 7 m/min - Acciaio / Steel - 14 m/min**  
**Leghe di alluminio - 32 m/min**



Per fori cilindrici e precisi in lamiere di acciaio, tubi, profilati, leghe leggere, plastica, plexiglass sino a 5 mm spessore.  
For parallel and precise holes in metal sheets, pipes, structurals, light alloys, plastics, plexiglass up to 5 mm thickness. /  
Perçage précise et haute rendement dans tous matériaux de faible épaisseur (max 5 mm). / Grande rendimiento y  
precision para cortar tubo y chapa de acero, aleaciones ligeras, plexiglass (5 mm profundidad). / Große Präzision und  
Leistung zum Bohren größerer Löcher in dünnwandige Materialien oder zum Aufbohren bereits vorhandener Löcher

3 pcs -  
Gr.2 4÷12 mm  
Gr.4 4÷20 mm  
Gr.6 4÷30 mm

**01259103**

€ 246,278

# 01236

## Utensili conici a gradino rivestiti al TiAlN

TiAlN coated step drill bits / Forets étages revêtus au TiAlN

Brocas escalonadas con recubrimiento de TiAlN / Stufenbohrer TiAlN beschichtet

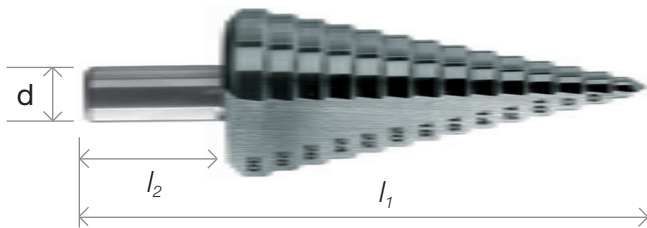
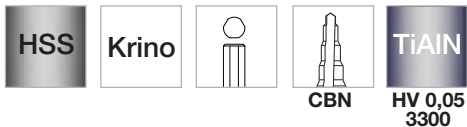

Gr.	Ø min.-max	Progressione Step	N° Gradini N° Steps	d	l <sub>2</sub>	l <sub>1</sub>	cod.	€ cad/each
-----	------------	-------------------	---------------------	---	----------------	----------------	------	------------

Metric - per costruzione - for construction

1	4 ÷ 12	2	5	6	21	56	0123601	48,780
2	4 ÷ 12	1	9	6	21	70	0123602	50,042
3	12 ÷ 20	1	9	10	25	85	0123603	125,380
4	4 ÷ 20	2	9	10	25	85	0123604	82,841
5	20 ÷ 30	1	11	10	25	97	0123605	216,056
6	4 ÷ 30	2	13	10	25	97	0123606	165,683
7	30 ÷ 40	1	11	13	21	97	0123607	310,086
8	40 ÷ 50	1	11	13	21	100	0123608	423,160
9	6 ÷ 36	3	10	10	25	80	0123609	259,713
10	10 ÷ 58	3	12	13	25	90	0123610	578,762
11	4 ÷ 39	3	13	10	25	107	0123611	270,911

Pg

21	6,3 ÷ 26,75	-	7	10	25	91	0123621	200,386
22	6 ÷ 30,5	-	7	10	25	80	0123622	143,296
23	6 ÷ 37	-	7	10	25	85	0123623	275,382
24	6 ÷ 38	-	11	10	25	96	0123624	263,076



USO INTENSIVO  
INTENSIVE USE  
R<sub>c</sub>1200 N/mm<sup>2</sup>

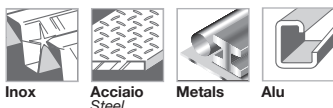

Velocità di taglio consigliata /  
Recommended cutting speed  
Inox - 9 m/min - Acciaio / Steel - 16 m/min  
Leghe di alluminio - 34 m/min



Per fori cilindrici e precisi in lamiere di acciaio, tubi, profilati, leghe leggere, plastica, plexiglass sino a 5 mm spessore.  
For parallel and precise holes in metal sheets, pipes, structurals, light alloys, plastics, plexiglass up to 5 mm thickness. /  
Perçage précise et haute rendement dans tous matériaux de faible épaisseur (max 5 mm). / Grande rendimiento y  
precision para cortar tubo y chapa de acero, aleaciones ligeras, plexiglass (5 mm profundidad). / Große Präzision und  
Leistung zum Bohren größerer Löcher in dünnwandige Materialien oder zum Aufbohren bereits vorhandener Löcher

3 pcs -  
Gr.2 4÷12 mm  
Gr.4 4÷20 mm  
Gr.6 4÷30 mm  
**01259104**

€ 269,100

## 01254

### Utensili conici universali per prefiori di filettatura di tubi per cavi di conduzione elettrica

Universal step drill bits for cables connections / Forets étages universelles pour tubes avec armature en acier

Brocas escalonadas universales para tubos de conducción eléctrica / Universal-Stufenbohrer für Kabelverschraubungen

**Combinato UNIVERSALE: per fori nocciolo e fori passanti DIN EN 60423**

COMBINED UNIVERSAL: for core holes and through holes DIN EN 60423



**0125405**

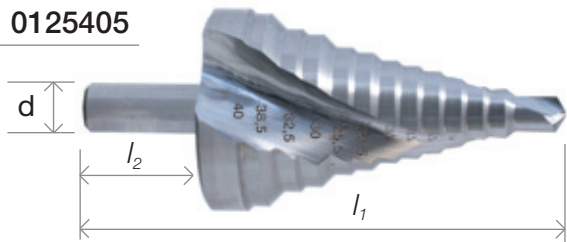

Ø min.-max	d	l <sub>2</sub>	l <sub>1</sub>	cod.	€ cad/each
7÷40,5	12	25	95	0125405	157,320

**M 12x1,5 - 40x1,5**

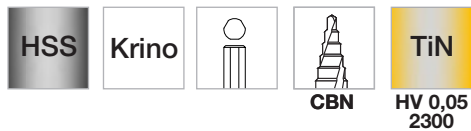

**0125406**

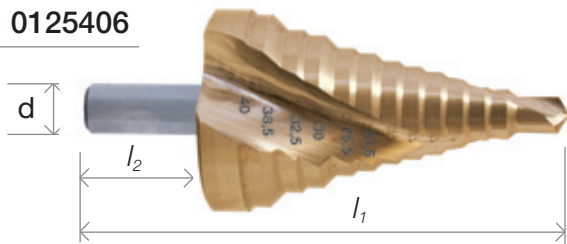

Ø min.-max	d	l <sub>2</sub>	l <sub>1</sub>	cod.	€ cad/each
7÷40,5	12	25	95	0125406	243,225

**M 12x1,5 - 40x1,5**

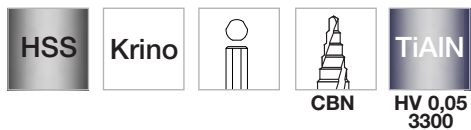

**0125407**

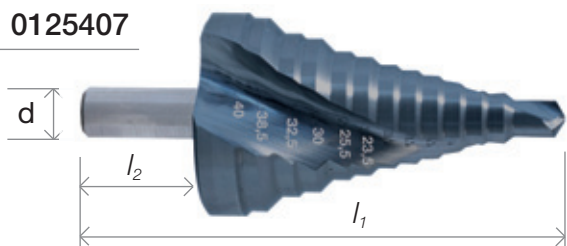

Ø min.-max	d	l <sub>2</sub>	l <sub>1</sub>	cod.	€ cad/each
7÷40,5	12	25	95	0125407	273,240

**M 12x1,5 - 40x1,5**

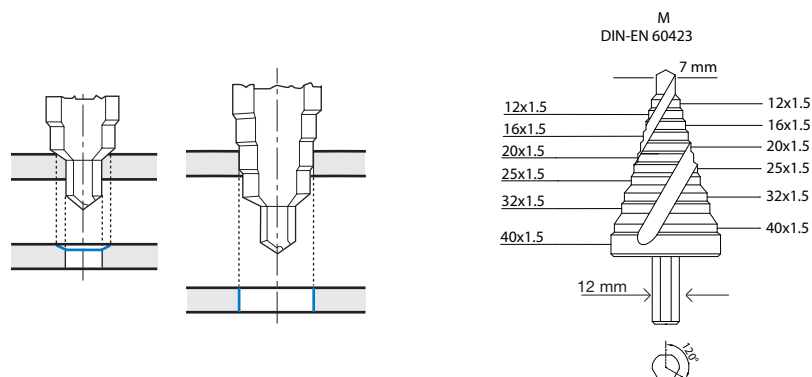

# 01254

## Utensili conici universali per prefiori di filettatura di tubi per cavi di conduzione elettrica

Universal step drill bits for cables connections / Forets étages universelles pour tubes avec armature en acier

Brocas escalonadas universales para tubos de conducción eléctrica / Universal-Stufenbohrer für Kabelverschraubungen

**Combinato UNIVERSALE: per fori nocciolo e fori passanti DIN EN 40430**

COMBINED UNIVERSAL: for core holes and through holes DIN EN 40430

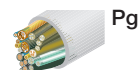

**0125403**

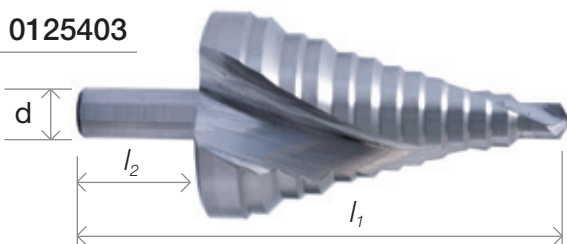

Ø min.-max	d	l <sub>2</sub>	l <sub>1</sub>	cod.	€ cad/each
8÷37	12	25	95	0125403	154,215

**Pg 7÷29**

**0125404**

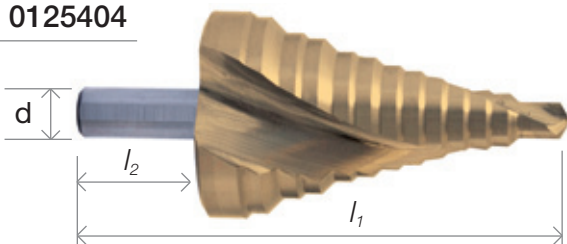

Ø min.-max	d	l <sub>2</sub>	l <sub>1</sub>	cod.	€ cad/each
8÷37	12	25	95	0125404	224,595

**Pg 7÷29**

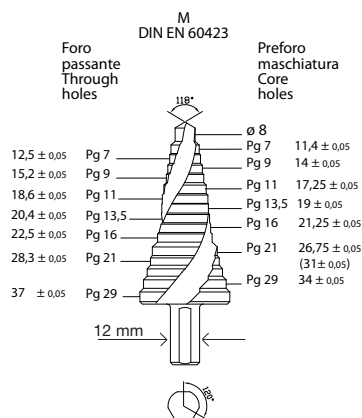





## ➤ FRESE A CAROTARE

Questi utensili di recente generazione permettono un taglio veloce ed economico negli acciai da costruzione, ghisa, leghe leggere, utilizzando macchine perforatrici a supporto elettromagnetico con attacco Weldon e Quick-in.

# CUTTING

## CUTTING TOOLS ENGINEERING

These new generation tools allow cutting steel, cast iron and light alloys quickly and cost-effectively, using drilling machines electromagnetic support and Weldon and Quick-in bit.

Ces outils de dernière génération permettent une découpe rapide et économique dans les aciers de construction, la fonte, les alliages légers, en utilisant des perceuses à support électromagnétique avec adaptateur Weldon et Quick-in.

Estos utensilios de reciente generación permiten un corte rápido y económico en los aceros de construcción, hierro fundido, aleaciones ligeras, utilizando máquinas perforadoras con soporte electromagnético con empalme Weldon e Quick-in.

Diese Werkzeuge der neuesten Generation ermöglichen einen schnellen und ökonomischen Schnitt in Baustahl, Gusseisen, Leichtmetalle durch Verwendung von Bohrmaschinen mit elektromagnetischer Unterstützung mit Weldon- und Quick-in-Anschluss.

## 21200

### Frese a carotare con attacco Weldon per macchine a supporto magnetico e trapani a colonna

Weldon shank HSS core drills for magnetic and pillar drilling machines / Fraises HSS à carotter avec Weldon queue pour machines à embase magnétique et perceuses fixes / Fresas HSS con mango Weldon para maquinas con base magnética y taladros estacionarios

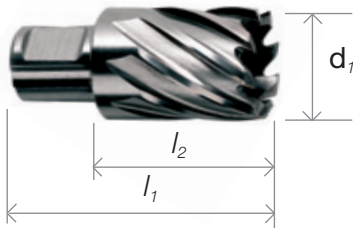

d <sub>1</sub>	l <sub>2</sub>	l <sub>1</sub>	pcs	cod.	€ cad/each
12	40	63	1	212001200	27,769
13	40	63	1	212001300	28,504
14	40	63	1	212001400	33,451
15	40	63	1	212001500	34,186
16	40	63	1	212001600	36,453
17	40	63	1	212001700	38,088
18	40	63	1	212001800	39,899
19	40	63	1	212001900	40,934
20	40	63	1	212002000	42,176
21	40	63	1	212002100	43,367
22	40	63	1	212002200	44,650
23	40	63	1	212002300	45,964
24	40	63	1	212002400	48,852
25	40	63	1	212002500	50,249
26	40	63	1	212002600	57,815
27	40	63	1	212002700	59,368
28	40	63	1	212002800	60,982
29	40	63	1	212002900	62,649
30	40	63	1	212003000	64,387
31	40	63	1	212003100	67,472
32	40	63	1	212003200	69,242
33	40	63	1	212003300	71,063
34	40	63	1	212003400	72,916

d <sub>1</sub>	l <sub>2</sub>	l <sub>1</sub>	pcs	cod.	€ cad/each
35	40	63	1	212003500	74,841
36	40	63	1	212003600	76,849
37	40	63	1	212003700	78,898
38	40	63	1	212003800	81,403
39	40	63	1	212003900	83,825
40	40	63	1	212004000	85,439
41	40	63	1	212004100	98,335
42	40	63	1	212004200	100,747
43	40	63	1	212004300	102,362
44	40	63	1	212004400	104,783
45	40	63	1	212004500	123,320
46	40	63	1	212004600	125,742
47	40	63	1	212004700	128,154
48	40	63	1	212004800	130,576
49	40	63	1	212004900	132,987
50	40	63	1	212005000	135,409
51	40	63	1	212005100	147,301
52	40	63	1	212005200	150,189
53	40	63	1	212005300	153,087
54	40	63	1	212005400	155,964
55	40	63	1	212005500	160,394
60	40	63	1	212006000	189,415

Espulsore - Ejector	cod.	€
Ø 6,35x77 mm	28016001	10,071



Le frese a carotare permettono un taglio molto veloce ed economico nel ferro, acciaio da costruzione, ghisa, leghe leggere e metalli non ferrosi in genere. Speciale per piatti e lamiere di grande spessore, tubi, putrelle e profilati. The core drills allow a very fast and economical cut in, structural steel, iron, cast iron, light alloys and non-ferrous metals. Special for very thick metal plates and sheets, pipes, iron beam and structural steel. / Les fraises à carotter permettent une coupe rapide et économique, dans le fer, l'acier de construction, la fonte, les alliages légères et les métaux non ferreux. Spécial pour les plates en acier et la tôle, les tubes, les poutrelles et les profilés en acier. / Las coronas permiten el corte rápido y económico en hierro, acero de construcción, fundición, aleaciones ligeras y materiales no ferricos. Especial para platos de metal y chapas de gran espesor, tubos, vigas y perfilados.



6 pcs - Ø 12-14-16-18-20-22  
1 pcs

21210400 € 274,275

# 21202

## Frese a carotare con attacco Weldon per macchine a supporto magnetico e trapani a colonna

Weldon shank HSS core drills for magnetic and pillar drilling machines / Fraises HSS à carotter avec Weldon queue pour machines à embase magnétique et perceuses fixes / Fresas HSS con mango Weldon para maquinas con base magnética y taladros estacionarios

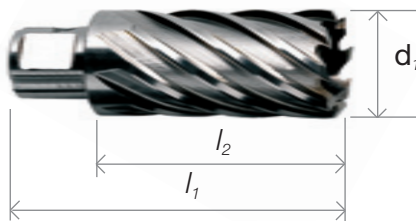

$d_1$	$l_2$	$l_1$	pcs	cod.	€ cad/each	$d_1$	$l_2$	$l_1$	pcs	cod.	€ cad/each
12	60	83	1	212021200	38,585	35	60	83	1	212023500	95,292
13	60	83	1	212021300	39,371	36	60	83	1	212023600	97,435
14	60	83	1	212021400	46,265	37	60	83	1	212023700	99,588
15	60	83	1	212021500	47,010	38	60	83	1	212023800	101,741
16	60	83	1	212021600	49,939	39	60	83	1	212023900	103,883
17	60	83	1	212021700	51,967	40	60	83	1	212024000	106,036
18	60	83	1	212021800	54,182	41	60	83	1	212024100	123,227
19	60	83	1	212021900	55,269	42	60	83	1	212024200	125,380
20	60	83	1	212022000	56,604	43	60	83	1	212024300	128,247
21	60	83	1	212022100	57,888	44	60	83	1	212024400	130,389
22	60	83	1	212022200	59,254	45	60	83	1	212024500	155,467
23	60	83	1	212022300	60,661	46	60	83	1	212024600	158,334
24	60	83	1	212022400	64,336	47	60	83	1	212024700	160,487
25	60	83	1	212022500	65,805	48	60	83	1	212024800	163,354
26	60	83	1	212022600	76,662	49	60	83	1	212024900	166,221
27	60	83	1	212022700	78,091	50	60	83	1	212025000	176,312
28	60	83	1	212022800	80,244	51	60	83	1	212025100	205,044
29	60	83	1	212022900	81,672	52	60	83	1	212025200	210,581
30	60	83	1	212023000	86,692	53	60	83	1	212025300	216,129
31	60	83	1	212023100	87,406	54	60	83	1	212025400	221,666
32	60	83	1	212023200	89,559	55	60	83	1	212025500	221,666
33	60	83	1	212023300	90,987	60	60	83	1	212026000	237,222
34	60	83	1	212023400	93,140						

Espulsore - Ejector	cod.	€
 Ø 6,35x102 mm	28016002	11,685



Le frese a carotare permettono un taglio molto veloce ed economico nel ferro, acciaio da costruzione, ghisa, leghe leggere e metalli non ferrosi in genere. Speciale per piatti e lamiere di grande spessore, tubi, putrelle e profilati. The core drills allow a very fast and economical cut in, structural steel, iron, cast iron, light alloys and non-ferrous metals. Special for very thick metal plates and sheets, pipes, iron beam and structural steel. / Les fraises à carotter permettent une coupe rapide et économique, dans le fer, l'acier de construction, la fonte, les alliages légères et les métaux non ferreux. Spécial pour les plates en acier et la tôle, les tubes, les poutrelles et les profilés en acier. / Las coronas permiten el corte rápido y económico en hierro, acero de construcción, fundición, aleaciones ligeras y materiales no ferricos. Especial para platos de metal y chapas de gran espesor, tubos, vigas y perfilados.



6 pcs - Ø 12-14-16-18-20-22  
1 pcs 

21210402 € 320,684

## 21204

### Frese a carotare con attacco Weldon per macchine a supporto magnetico e trapani a colonna

Weldon shank core drills for magnetic and pillar drilling machines / Fraises à carotter avec Weldon queue pour machines à embase magnétique et perceuses fixes / Fresas con mango Weldon para maquinas con base magnética y taladros estacionarios

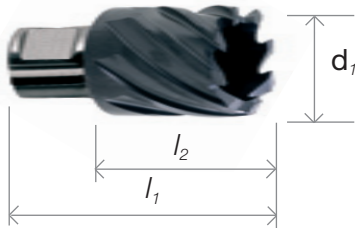

$d_1$	$l_2$	$l_1$	pcs	cod.	€ cad/each
12	40	63	1	212041200	48,904
13	40	63	1	212041300	48,904
14	40	63	1	212041400	52,495
15	40	63	1	212041500	54,172
16	40	63	1	212041600	56,211
17	40	63	1	212041700	58,022
18	40	63	1	212041800	60,134
19	40	63	1	212041900	63,414
20	40	63	1	212042000	64,863
21	40	63	1	212042100	68,000
22	40	63	1	212042200	69,480
23	40	63	1	212042300	77,553
24	40	63	1	212042400	80,927
25	40	63	1	212042500	82,552
26	40	63	1	212042600	101,554
27	40	63	1	212042700	102,496
28	40	63	1	212042800	104,380
29	40	63	1	212042900	107,195
30	40	63	1	212043000	109,079
31	40	63	1	212043100	126,177
32	40	63	1	212043200	127,077

$d_1$	$l_2$	$l_1$	pcs	cod.	€ cad/each
33	40	63	1	212043300	128,237
34	40	63	1	212043400	130,576
35	40	63	1	212043500	131,652
36	40	63	1	212043600	138,887
37	40	63	1	212043700	140,895
38	40	63	1	212043800	142,913
39	40	63	1	212043900	144,817
40	40	63	1	212044000	147,632
41	40	63	1	212044100	173,994
42	40	63	1	212044200	176,602
43	40	63	1	212044300	177,720
44	40	63	1	212044400	180,545
45	40	63	1	212044500	201,235
46	40	63	1	212044600	204,050
47	40	63	1	212044700	206,876
48	40	63	1	212044800	209,691
49	40	63	1	212044900	213,458
50	40	63	1	212045000	216,274
55	40	63	1	212045500	336,893
60	40	63	1	212046000	364,061

Espulsore - Ejector	cod.	€
Ø 6,35x77 mm	28016001	10,071



Le frese a carotare, per le caratteristiche illustrate, permettono un taglio molto veloce ed economico nel ferro, acciaio da costruzione, ghisa, leghe leggere e materiali non ferrosi in genere. Speciale per piatti e lamiere in acciaio di grande spessore, tubi, putrelle, profilati etc. As shown, the core drills allow a very fast and economic cut in iron, structural steel, cast iron, light alloys and nonferrous metals. Special for very thick metal plates and sheets, pipes, iron beam and structural steel. / Comme illustré, les fraises à carotter permettent un coupe très vite et économique dans le fer, l'acier de construction, la fonte, les alliages légers et les matériaux qui ne son pas ferreux. Spécial pour les plates en acier et la tôle, les tubes, poutrelles et profilés en acier. / Las fresas para sondear, cómo ilustrado, permiten de cortar muy rápidamente y económicamente hierro, acero de construcción, fundición, aleaciones ligeras y materiales no ferrosos en general. Especial para platos de metal y planchas muy gruesos, tubos, vigas y perfilados. / Wie illustriert erlauben die Kernbohrer einen schnellen und sparsamen Schnitt in Flacheisen, Baustahl, Gusseisen, Leichtmetall-Legierungen und Nichteisenmaterialien. Geeignet für Flächen und Bleche aus Stahl, Röhren, Eisenträger und Profilstähle.



6 pcs - Ø 12-14-16-18-20-22  
1 pcs

21210404 € 273,675

# 21205

## Frese a carotare con attacco Weldon per macchine a supporto magnetico e trapani a colonna

Weldon shank core drills for magnetic and pillar drilling machines / Fraises à carotter avec Weldon queue pour machines à embase magnétique et perceuses fixes / Fresas con mango Weldon para maquinas con base magnética y taladros estacionarios

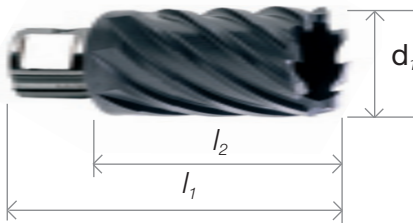

$d_1$	$l_2$	$l_1$	pcs	cod.	€ cad/each
12	60	83	1	212051200	66,758
13	60	83	1	212051300	66,758
14	60	83	1	212051400	68,155
15	60	83	1	212051500	70,794
16	60	83	1	212051600	74,458
17	60	83	1	212051700	78,412
18	60	83	1	212051800	81,175
19	60	83	1	212051900	84,332
20	60	83	1	212052000	86,009
21	60	83	1	212052100	89,310
22	60	83	1	212052200	91,349
23	60	83	1	212052300	99,412
24	60	83	1	212052400	103,883
25	60	83	1	212052500	105,674
26	60	83	1	212052600	128,071
27	60	83	1	212052700	129,861
28	60	83	1	212052800	132,542
29	60	83	1	212052900	134,333
30	60	83	1	212053000	140,605
31	60	83	1	212053100	151,348
32	60	83	1	212053200	154,039

$d_1$	$l_2$	$l_1$	pcs	cod.	€ cad/each
33	60	83	1	212053300	156,720
34	60	83	1	212053400	158,521
35	60	83	1	212053500	161,201
36	60	83	1	212053600	167,473
37	60	83	1	212053700	170,154
38	60	83	1	212053800	172,845
39	60	83	1	212053900	175,536
40	60	83	1	212054000	179,117
41	60	83	1	212054100	210,457
42	60	83	1	212054200	213,148
43	60	83	1	212054300	216,729
44	60	83	1	212054400	219,410
45	60	83	1	212054500	250,760
46	60	83	1	212054600	254,341
47	60	83	1	212054700	257,032
48	60	83	1	212054800	260,613
49	60	83	1	212054900	264,194
50	60	83	1	212055000	266,875
55	60	83	1	212055500	398,682
60	60	83	1	212056000	414,652

Espulsore - Ejector	cod.	€
Ø 6,35x102 mm	28016002	11,685



Le frese a carotare, per le caratteristiche illustrate, permettono un taglio molto veloce ed economico nel ferro, acciaio da costruzione, ghisa, leghe leggere e materiali non ferrosi in genere. Speciale per piatte e lamiere in acciaio di grande spessore, tubi, putrelle, profilati etc. As shown, the core drills allow a very fast and economic cut in iron, structural steel, cast iron, light alloys and nonferrous metals. Special for very thick metal plates and sheets, pipes, iron beam and structural steel. / Comme illustré, les fraises à carotter permettent un coupe très vite et économique dans le fer, l'acier de construction, la fonte, les alliages légers et les matériaux qui ne son pas ferreux. Spécial pour les plates en acier et la tôle, les tubes, poutrelles et profilés en acier. / Las fresas para sondear, cómo ilustrado, permiten de cortar muy rápidamente y económicamente hierro, acero de construcción, fundición, aleaciones ligeras y materiales no ferrosos en general. Especial para platos de metal y planchas muy gruesos, tubos, vigas y perfilados. / Wie illustriert erlauben die Kernbohrer einen schnellen und sparsamen Schnitt in Flacheisen, Baustahl, Gusseisen, Leichtmetall-Legierungen und Nichteisenmaterialien. Geeignet für Flächen und Bleche aus Stahl, Röhren, Eisenträger und Profilstähle.



6 pcs - Ø 12-14-16-18-20-22  
1 pcs

21210405 € 320,912

## 21206

### Frese a carotare con attacco Weldon per macchine a supporto magnetico e trapani a colonna

Weldon shank core drills for magnetic and pillar drilling machines / Fraises à carotter avec Weldon queue pour machines à embase magnétique et perceuses fixes / Fresas con mango Weldon para maquinas con base magnética y taladros estacionariostaladros estacionarios

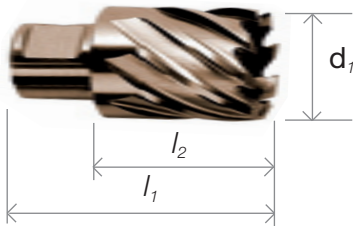

$d_1$	$l_2$	$l_1$	pcs	cod.	€ cad/each	$d_1$	$l_2$	$l_1$	pcs	cod.	€ cad/each
12	40	63	1	212061200	45,157	33	40	63	1	212063300	113,364
13	40	63	1	212061300	48,024	34	40	63	1	212063400	119,129
14	40	63	1	212061400	53,799	35	40	63	1	212063500	123,921
15	40	63	1	212061500	57,639	36	40	63	1	212063600	128,723
16	40	63	1	212061600	60,527	37	40	63	1	212063700	134,498
17	40	63	1	212061700	60,527	38	40	63	1	212063800	139,301
18	40	63	1	212061800	60,651	39	40	63	1	212063900	145,066
19	40	63	1	212061900	61,965	40	40	63	1	212064000	149,858
20	40	63	1	212062000	63,766	41	40	63	1	212064100	155,633
21	40	63	1	212062100	65,609	42	40	63	1	212064200	162,360
22	40	63	1	212062200	67,544	43	40	63	1	212064300	167,163
23	40	63	1	212062300	69,562	44	40	63	1	212064400	174,843
24	40	63	1	212062400	73,940	45	40	63	1	212064500	186,279
25	40	63	1	212062500	76,041	46	40	63	1	212064600	189,860
26	40	63	1	212062600	87,458	47	40	63	1	212064700	193,442
27	40	63	1	212062700	90,449	48	40	63	1	212064800	197,023
28	40	63	1	212062800	93,140	49	40	63	1	212064900	201,504
29	40	63	1	212062900	94,930	50	40	63	1	212065000	205,085
30	40	63	1	212063000	97,621	55	40	63	1	212065500	242,697
31	40	63	1	212063100	102,092	60	40	63	1	212066000	373,418
32	40	63	1	212063200	105,674						

Espulsore - Ejector	cod.	€
Ø 6,35x77 mm	28016001	10,071



Le frese a carotare al cobalto 5% permettono un taglio molto veloce ed economico nell'acciaio inox, acciaio da costruzione, ferro, ghisa, leghe leggere e metalli non ferrosi in genere. Speciale per piatti e lamiere di grande spessore, tubi, putrelle e profilati. The 5% cobalt core drills allow a very fast and economical cut in, stainless steel, structural steel, iron, cast iron, light alloys and non-ferrous metals. Special for very thick metal plates and sheets, pipes, iron beam and structural steel. / Les fraises à carotter au 5% du cobalt permettent une coupe rapide et économique, dans l'acier inox, l'acier de construction, le fer, la fonte, les alliages légères et les métaux non ferreux. Spécial pour les plates en acier et la tôle, les tubes, les poutrelles et les profilés en acier. / Las coronas de cobalto 5% permiten el corte rapido y economico en acero inoxidable, acero de construcción, fundición, aleaciones ligeras y materiales no ferricos. Especial para platos de metal y chapas de gran espesor, tubos, vigas y perfilados. / Die Kernbohrer aus Kobalt 5% erlauben einen schnellen und sparsamen Schnitt in rostfreier Stahl, Flacheisen, Baustahl, Gusseisen, Leichtmetall-Legierungen und Nichteisenmaterialien. Geeignet für Flächen und Bleche aus Stahl von großer Stärke, Röhren, Eisenträger und Profilstähle.



6 pcs - Ø 12-14-16-18-20-22  
1 pcs

21210406 € 424,350

# 21207

## Frese a carotare con attacco Weldon per macchine a supporto magnetico e trapani a colonna

Weldon shank core drills for magnetic and pillar drilling machines / Fraises à carotter avec Weldon queue pour machines à embase magnétique et perceuses fixes / Fresas con mango Weldon para maquinas con base magnética y taladros estacionarios

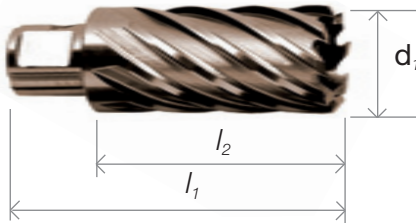

$d_1$	$l_2$	$l_1$	pcs	cod.	€ cad/each	$d_1$	$l_2$	$l_1$	pcs	cod.	€ cad/each
12	60	83	1	212071200	65,122	33	60	83	1	212073300	153,946
13	60	83	1	212071300	66,468	34	60	83	1	212073400	157,175
14	60	83	1	212071400	78,049	35	60	83	1	212073500	160,394
15	60	83	1	212071500	79,322	36	60	83	1	212073600	166,118
16	60	83	1	212071600	84,632	37	60	83	1	212073700	167,649
17	60	83	1	212071700	87,851	38	60	83	1	212073800	171,675
18	60	83	1	212071800	91,887	39	60	83	1	212073900	176,571
19	60	83	1	212071900	93,492	40	60	83	1	212074000	178,931
20	60	83	1	212072000	95,913	41	60	83	1	212074100	207,952
21	60	83	1	212072100	98,335	42	60	83	1	212074200	211,978
22	60	83	1	212072200	100,747	43	60	83	1	212074300	216,015
23	60	83	1	212072300	103,169	44	60	83	1	212074400	220,041
24	60	83	1	212072400	108,810	45	60	83	1	212074500	262,755
25	60	83	1	212072500	111,231	46	60	83	1	212074600	266,792
26	60	83	1	212072600	128,961	47	60	83	1	212074700	270,818
27	60	83	1	212072700	132,190	48	60	83	1	212074800	275,652
28	60	83	1	212072800	134,602	49	60	83	1	212074900	279,688
29	60	83	1	212072900	137,831	50	60	83	1	212075000	284,522
30	60	83	1	212073000	141,050	55	60	83	1	212075500	335,299
31	60	83	1	212073100	147,498	60	60	83	1	212076000	386,883
32	60	83	1	212073200	150,727						

Espulsore - Ejector	cod.	€
Ø 6,35x102 mm	28016002	11,685



Le frese a carotare al cobalto 5% permettono un taglio molto veloce ed economico nell'acciaio inox, acciaio da costruzione, ferro, ghisa, leghe leggere e metalli non ferrosi in genere. Speciale per piatti e lamiere di grande spessore, tubi, putrelle e profilati. The 5% cobalt core drills allow a very fast and economical cut in, stainless steel, structural steel, iron, cast iron, light alloys and non-ferrous metals. Special for very thick metal plates and sheets, pipes, iron beam and structural steel. / Les fraises à carotter au 5% du cobalt permettent une coupe rapide et économique, dans l'acier inox, l'acier de construction, le fer, la fonte, les alliages légers et les métaux non ferreux. Spécial pour les plates en acier et la tôle, les tubes, les poutrelles et les profilés en acier. / Las coronas de cobalto 5% permiten el corte rapido y economico en acero inoxidable, acero de construcción, fundición, aleaciones ligeras y materiales no ferricos. Especial para platos de metal y chapas de gran espesor, tubos, vigas y perfilados. / Die Kernbohrer aus Kobalt 5% erlauben einen schnellen und sparsamen Schnitt in rostfreier Stahl, Flacheisen, Baustahl, Gusseisen, Leichtmetall-Legierungen und Nichteisenmaterialien. Geeignet für Flächen und Bleche aus Stahl von großer Stärke, Röhren, Eisenträger und Profilstähle.



6 pcs - Ø 12-14-16-18-20-22  
1 pcs

21210407 € 571,372



## 21216

### Frese a carotare in metallo duro con attacco Weldon per macchine a supporto magnetico

Weldon shank carbide tip core drill for magnetic drilling machines / Fraises à carotter au carbure de tungstène avec Weldon queue pour machines à embase magnétique / Fresas con dientes de metal duro y mango Weldon para maquinas con base magnética

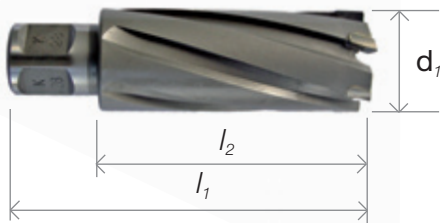

d <sub>1</sub>	l <sub>2</sub>	l <sub>1</sub>	pcs	cod.	€ cad/each
12	70	93	1	212161200	94,299
14	70	93	1	212161400	94,299
15	70	93	1	212161500	94,299
16	70	93	1	212161600	94,299
17	70	93	1	212161700	94,299
18	70	93	1	212161800	94,299
19	70	93	1	212161900	94,299
20	70	93	1	212162000	96,400
21	70	93	1	212162100	96,400
22	70	93	1	212162200	96,400
23	70	93	1	212162300	96,400
24	70	93	1	212162400	96,400
25	70	93	1	212162500	96,400
26	70	93	1	212162600	105,829
27	70	93	1	212162700	105,829
28	70	93	1	212162800	105,829
29	70	93	1	212162900	113,167
30	70	93	1	212163000	113,167
31	70	93	1	212163100	117,359
32	70	93	1	212163200	117,359
33	70	93	1	212163300	132,025
34	70	93	1	212163400	132,025
35	70	93	1	212163500	132,025
36	70	93	1	212163600	132,025
37	70	93	1	212163700	132,025
38	70	93	1	212163800	132,025

d <sub>1</sub>	l <sub>2</sub>	l <sub>1</sub>	pcs	cod.	€ cad/each
39	70	93	1	212163900	132,025
40	70	93	1	212164000	132,025
41	70	93	1	212164100	150,882
42	70	93	1	212164200	150,882
43	70	93	1	212164300	150,882
44	70	93	1	212164400	150,882
45	70	93	1	212164500	150,882
46	70	93	1	212164600	169,740
47	70	93	1	212164700	169,740
48	70	93	1	212164800	169,740
49	70	93	1	212164900	169,740
50	70	93	1	212165000	169,740
51	70	93	1	212165100	208,511
52	70	93	1	212165200	208,511
53	70	93	1	212165300	208,511
54	70	93	1	212165400	208,511
55	70	93	1	212165500	208,511
56	70	93	1	212165600	230,515
57	70	93	1	212165700	230,515
58	70	93	1	212165800	230,515
59	70	93	1	212165900	230,515
60	70	93	1	212166000	230,515
65	70	93	1	212166500	251,474
70	70	93	1	212167000	313,295
75	70	93	1	212167500	335,299
80	70	93	1	212168000	355,212

Espulsore - Ejector	cod.	€
 Ø 6,35x112 mm per frese Ø 12 mm	21216000	22,770
Ø 7,1x112 mm per frese Ø 14-16 mm	21216001	22,770

Espulsore - Ejector	cod.	€
 Ø 8,0x112 mm per frese Ø 17-80 mm	21216002	22,770



Consigliate per il taglio molto veloce, economico e con grande rendimento in acciaio inox, acciai refrattari, acciai resistenti agli acidi, HARDOX®, WELDOX®400, tutti gli acciai in genere, ghisa,... Particolarmente adatto al taglio delle putrelle e delle rotaie. The core drills allow a very fast and economical cut in stainless steel, acid resistant steel, HARDOX®, WELDOX®400, steel and cast iron,... Suitable for cut iron beam and rails. / Recommandé pour la coupe très rapide, en l'acier inoxydable avec une grande efficacité, en acier réfractaire, inoxydable, résistant aux acides, HARDOX®, WELDOX® 400, tous les acciers en fonte générale, ... Particulièrement adapté pour couper les poutres et les rails. / Recomendado para el corte muy rápido y con gran eficiencia en l'acero inoxidable, acero refractario, acero resistente a los ácidos, HARDOX®, WELDOX® 400, todos los aceros en hierro fundido en general, especialmente adecuados para el corte de las vigas.

## Accessori per l'utilizzo delle frese a carotare Weldon

Accessories for core drills / Accessoires pour fraises à carotter

Accesorios para coronas fresas / Zubehör für Kernbohrmaschinen

### 28015



#### Adattatore Quick-in-Weldon

Quick-in-Weldon adapter

Descrizione Description	pcs 	cod.	€ cad/each
Quick in 18-Weldon	1	28015002	51,139

### 28012



#### Mandrino senza lubrificazione interna

Holder without lubrication / Mandrin sans lubrification

Portabroca sin lubricación / Bohrfutter ohne Schmierung

MT	$l_1$	pcs 	cod.	€ cad/each
2	160	1	28012001	157,982
3	175	1	28012002	157,962

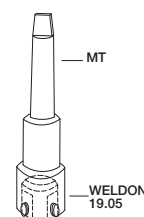

### 28013

#### Mandrino con lubrificazione interna

Holder with lubrication / Mandrin avec lubrification

Portabroca con lubricación / Bohrfutter mit Schmierung



MT	$l_1$	pcs 	cod.	€ cad/each
2	160	1	28013001	225,682
3	160	1	28013002	225,682
2	160	1	28013003	248,069
3	160	1	28013004	248,069

### 28014

#### Mandrino a serraggio rapido con lubrificazione

Automatic quick-in arbor with interior lubrication / Mandrin à serrage automatique avec lubrification

Portabroca automático con lubricación / Automatisches Spannfutter mit Schmierung



MT	$l_1$	pcs 	cod.	€ cad/each
2	160	1	28014001	356,433
3	160	1	28014002	356,433
2	160	1	28014003	356,433
3	160	1	28014004	356,433

## 21211

### Frese a carotare con attacco Quick-IN 18 mm per macchine a supporto magnetico

Quick-IN 18 mm shank core drill for magnetic drilling machines / fraises à carotter avec Quick-IN 18 mm queue pour machines à embase magnétique / Fresas con mango Quick-IN 18 mm para maquinas con base magnética

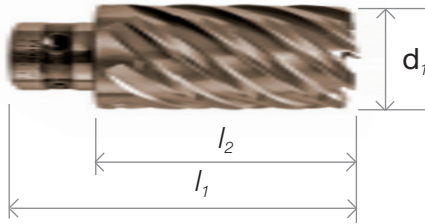
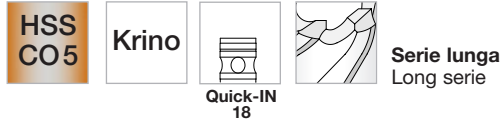

$d_1$	$l_2$	$l_1$	pcs	cod.	€ cad/each	$d_1$	$l_2$	$l_1$	pcs	cod.	€ cad/each
12	67	90	1	2121101200	61,686	32	67	90	1	2121103200	141,319
13	67	90	1	2121101300	61,686	33	67	90	1	2121103300	141,319
14	67	90	1	2121101400	61,686	34	67	90	1	2121103400	147,446
15	67	90	1	2121101500	64,698	35	67	90	1	2121103500	151,524
16	67	90	1	2121101600	64,698	36	67	90	1	2121103600	161,636
17	67	90	1	2121101700	74,686	37	67	90	1	2121103700	161,636
18	67	90	1	2121101800	74,686	38	67	90	1	2121103800	168,726
19	67	90	1	2121101900	77,811	39	67	90	1	2121103900	172,804
20	67	90	1	2121102000	83,825	40	67	90	1	2121104000	175,712
21	67	90	1	2121102100	89,735	41	67	90	1	2121104100	177,854
22	67	90	1	2121102200	97,042	42	67	90	1	2121104200	181,839
23	67	90	1	2121102300	97,042	43	67	90	1	2121104300	191,941
24	67	90	1	2121102400	104,245	44	67	90	1	2121104400	203,119
25	67	90	1	2121102500	112,308	45	67	90	1	2121104500	218,157
26	67	90	1	2121102600	112,308	46	67	90	1	2121104600	228,373
27	67	90	1	2121102700	118,218	47	67	90	1	2121104700	239,654
28	67	90	1	2121102800	124,231	48	67	90	1	2121104800	253,627
29	67	90	1	2121102900	124,231	49	67	90	1	2121104900	262,217
30	67	90	1	2121103000	130,358	50	67	90	1	2121105000	272,971
31	67	90	1	2121103100	139,704						

Espulsore - Ejector	cod.	€
Ø 6,35x102 mm	28016002	11,685



Consigliate per il taglio molto veloce, economico e con grande rendimento in acciaio inox, acciai da costruzione, ferro, ghisa, leghe leggere e metalli non ferrosi in genere. Particolarmente adatto al taglio di piatti e lamiere di grandi spessori, tubi, putrelle e profilati. The core drills allow a very fast and economical cut in stainless steel, structural steel, iron, cast iron, light alloys and non-ferrous metals. Special for very thick metal plates and sheets, pipes, iron beam and structural steel. / Les fraises à carotter permettent une coupe rapide et économique dans l'acier inox, l'acier de construction, le fer, la fonte, les alliages légers et les métaux non ferreux. Spécial pour les plates en acier et la tôle, les tubes, les poutrelles et les profilés en acier. / Las coronas permiten el corte rapido y economico en acero inoxidable, acero de construcción, fundición, aleaciones ligeras y materiales no ferricos. Especial para platos de metal y chapas de gran espesor, tubos, vigas y perfilados.

# 21212

## Frese a carotare in metallo duro con attacco Quick-IN 18 mm per macchine a supporto magnetico

Quick-IN 18 mm shank carbide tip core drill for magnetic drilling machines / Fraises à carotter au carbure de tungstène avec Quick-IN 18 mm queue pour machines à embase magnétique / Fresas con dientes de metal duro y mango Quick-IN 18 mm para maquinas con base magnética

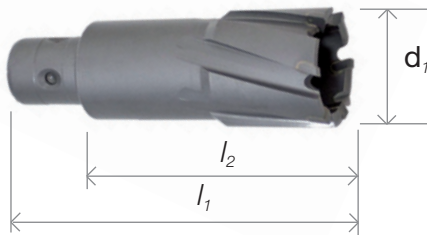
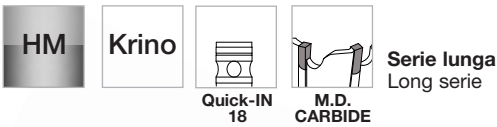

$d_1$	$l_2$	$l_1$	pcs	cod.	€ cad/each
12	70	93	1	212121200	86,112
13	70	93	1	212121300	86,112
14	70	93	1	212121400	86,112
15	70	93	1	212121500	86,112
16	70	93	1	212121600	86,112
17	70	93	1	212121700	86,112
18	70	93	1	212121800	86,112
19	70	93	1	212121900	86,112
20	70	93	1	212122000	86,112
21	70	93	1	212122100	86,112
22	70	93	1	212122200	86,112
23	70	93	1	212122300	86,112
24	70	93	1	212122400	86,112
25	70	93	1	212122500	86,112
26	70	93	1	212122600	93,864
27	70	93	1	212122700	93,864
28	70	93	1	212122800	93,864
29	70	93	1	212122900	93,864
30	70	93	1	212123000	93,864
31	70	93	1	212123100	112,805
32	70	93	1	212123200	112,805

$d_1$	$l_2$	$l_1$	pcs	cod.	€ cad/each
33	70	93	1	212123300	112,805
34	70	93	1	212123400	112,805
35	70	93	1	212123500	112,805
36	70	93	1	212123600	129,168
37	70	93	1	212123700	129,168
38	70	93	1	212123800	129,168
39	70	93	1	212123900	129,168
40	70	93	1	212124000	129,168
41	70	93	1	212124100	154,143
42	70	93	1	212124200	154,143
43	70	93	1	212124300	154,143
44	70	93	1	212124400	154,143
45	70	93	1	212124500	154,143
46	70	93	1	212124600	177,389
47	70	93	1	212124700	177,389
48	70	93	1	212124800	177,389
49	70	93	1	212124900	177,389
50	70	93	1	212125000	177,389
55	70	93	1	212125500	200,645
60	70	93	1	212126000	220,445

Espessore - Ejector	cod.	€
 Ø 6,35x102 mm	28016002	11,685

Adattatore Weldon-Quick-in Weldon-Quick in adapter	cod.	€
	28015001	51,947



Consigliate per il taglio molto veloce, economico e con grande rendimento in acciaio inox, acciai refrattari, acciai resistenti agli acidi, HARDOX®, WELDOX®400, tutti gli acciai in genere, ghisa,... Particolarmente adatto al taglio delle putrelle e delle rotaie. The core drills allow a very fast and economical cut in stainless steel, acid resistant steel, HARDOX®, WELDOX®400, steel and cast iron,... Suitable for cut iron beam and rails. / Recommandé pour la coupe très rapide, en l'acier inoxydable avec une grande efficacité, en acier réfractaire, inoxydable, résistant aux acides, HARDOX®, WELDOX® 400, tous les aciers en fonte générale, ... Particulièrement adapté pour couper les poutres et les rails. / Recomendado para el corte muy rápido y con gran eficiencia en l'acero inoxidable, acero refractario, acero resistente a los ácidos, HARDOX®, WELDOX® 400, todos los aceros en hierro fundido en general, especialmente adecuados para el corte de las vigas.



## > ALESATORI

Reamers  
Al soirs  
scariadores  
Reibahlen

Gli utensili ad alesare, nelle versioni in acciaio HSS e cobalto 5%, sono propedeutici per tutte le operazioni di finitura sui materiali ferrosi, come preparazione alla successive lavorazioni di maschiatura.

# CUTTING

## CUTTING TOOLS ENGINEERING

Reaming tools, in HSS steel and 5% cobalt, are suitable for machining ferrous materials, in order to prepare them for the subsequent tapping work.

Les outils à aléser, dans la version en acier HSS et cobalt 5 %, permettent de préparer toutes les opérations de finition sur les matériaux ferreux, pour l'usinage ultérieur de taraudage.

Los utensilios para escariar, en las versiones de acero HSS y cobalto 5%, son propedéuticos para todas las operaciones de acabado sobre materiales ferrosos, como preparación a los siguientes trabajos de roscado.

Die Werkzeuge zum Ausbohren in den Ausführungen HSS-Stahl und 5% Cobalt-Anteil sind vorbereitend für alle Feinbearbeitungsvorgänge auf Eisenwerkstoffen wie die Vorbereitung für nachfolgende Gewindebohrbearbeitungen.

## 29020

### Alesatori a macchina HSS-CO a codolo cilindrico

HSS-CO machine reamers / Alésoirs machine HSS-CO

Escariadores a maquina HSS-CO / Maschinenreibahlen HSS-CO



$d_1$ g6	$d_2$ h9	$l_2$	$l_1$	Z	pcs 	cod.	€ cad/each
3	3,0	15	61	6	1	290200300	24,840
4	4,0	19	75	6	1	290200400	26,144
5	5,0	23	86	6	1	290200500	27,945
6	6,0	26	93	6	1	290200600	28,442
7	7,0	30	109	6	1	290200700	33,658
8	8,0	32	117	6	1	290200800	34,776
9	9,0	36	125	6	1	290200900	43,967
10	10,0	38	133	6	1	290201000	41,048
11	10,0	41	142	8	1	290201100	58,809
12	10,0	44	151	8	1	290201200	62,845
13	10,0	44	151	8	1	290201300	70,111
14	12,5	47	160	8	1	290201400	72,409
15	12,5	50	162	8	1	290201500	74,768
16	12,5	52	170	8	1	290201600	78,370
17	14,0	54	175	8	1	290201700	98,987
18	14,0	56	182	8	1	290201800	101,285
19	16,0	58	189	10	1	290201900	119,294
20	16,0	60	195	10	1	290202000	114,264

#### Decimali e centesimali su richiesta

Decimal and centesimal reamers on demand



Per operazioni di finitura di fori passanti in tolleranza H7 di materiali ferrosi e non ferrosi. Suitable for finishing operations, inside through holes with H7 tolerance.

Spessore di sovrametallo consigliato. - Removable stock thickness

0,1 mm per alesatori con  $d_1 \leq 4$  mm - for reamers  $d_1 \leq 4$  mm

0,2 mm per alesatori con  $4 < d_1 \leq 11$  mm - for reamers  $4 < d_1 \leq 11$  mm

0,3 mm per alesatori con  $11 < d_1 \leq 20$  mm - for reamers  $11 < d_1 \leq 20$  mm

# 29021

## Alesatori a macchina HSS-CO a codolo cilindrico per centri di lavoro CNC

HSS-CO machine reamers / Alésoirs machine HSS-CO

Escariadores a maquina HSS-CO / Maschinenreibahlen HSS-CO

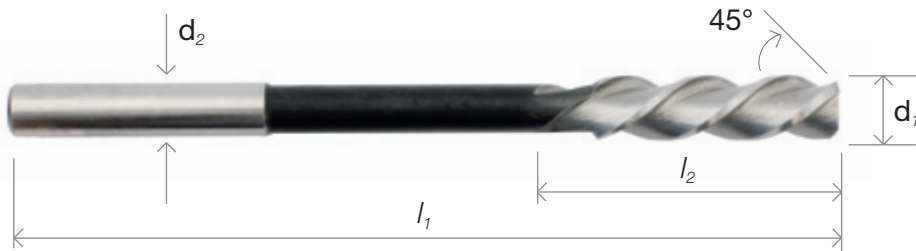
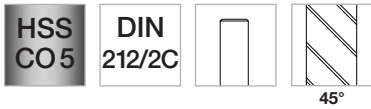

$d_1$	$d_2$	$l_2$	$l_1$	$z$	pcs 	cod.	€ cad/each
3	3,0	15	61	3	1	290210300	28,980
4	4,0	19	75	3	1	290210400	43,781
5	5,0	23	86	3	1	290210500	45,271
6	6,0	26	93	3	1	290210600	47,382
7	7,0	30	109	3	1	290210700	52,909
8	8,0	32	117	3	1	290210800	56,449
9	9,0	36	125	3	1	290210900	53,468
10	10,0	38	133	3	1	290211000	67,813
11	10,0	41	142	3	1	290211100	89,735
12	10,0	44	151	3	1	290211200	101,161
13	10,0	44	151	3	1	290211300	81,227
14	12,5	47	160	3	1	290211400	104,701
16	12,5	52	170	3	1	290211600	131,900
18	14,0	56	182	3	1	290211800	182,015
20	16,0	60	195	3	1	290212000	189,032



Per operazioni di finitura di fori passanti in tolleranza H7 di materiali ferrosi e non ferrosi. Il numero dispari di taglienti genera fori con minori errori di circolarità ed evita imperfezioni dovute a vibrazioni. Suitable for finishing operations, inside through holes with H7 tolerance.

Spessore di sovrametallo consigliato. - Removable stock thickness

0,1 mm per alesatori con  $d_1 \leq 4$  mm - for reamers  $d_1 \leq 4$  mm

0,2 mm per alesatori con  $4 < d_1 \leq 11$  mm - for reamers  $4 < d_1 \leq 11$  mm

0,3 mm per alesatori con  $11 < d_1 \leq 20$  mm - for reamers  $11 < d_1 \leq 20$  mm



## 29026

### Alesatori a macchina HSS-CO con codolo conico Morse

Morse taper shank HSS-CO machine reamers / Alésoirs machine HSS-CO queue conique

Escariadores a maquina HSS-CO mango conico Morse / Morsekegelmaschinenreibahlen HSS-CO

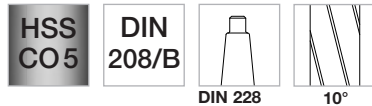

$d_1$	MK	$l_2$	$l_1$	z	pcs 	cod.	€ cad/each
5	1	23	133	6	1	290260500	43,170
6	1	26	138	6	1	290260600	41,918
7	1	31	150	6	1	290260700	42,549
8	1	33	156	6	1	290260800	43,170
9	1	36	162	6	1	290260900	43,801
10	1	38	168	6	1	290261000	44,422
11	1	41	175	8	1	290261100	47,548
12	1	44	182	8	1	290261200	49,432
13	1	44	182	8	1	290261300	51,305
14	1	47	189	8	1	290261400	57,556
15	2	50	204	8	1	290261500	65,070
16	2	52	210	8	1	290261600	70,701
17	2	54	214	8	1	290261700	71,953
18	2	56	219	8	1	290261800	77,584
19	2	58	223	10	1	290261900	81,962
20	2	60	228	10	1	290262000	91,349
21	2	62	232	10	1	290262100	93,222
22	2	64	237	10	1	290262200	99,484
23	2	66	241	10	1	290262300	106,367
24	3	68	268	10	1	290262400	128,889
25	3	68	268	10	1	290262500	128,889
26	3	70	273	10	1	290262600	145,148
27	3	71	277	10	1	290262700	146,401
28	3	71	277	10	1	290262800	160,166
30	3	73	281	10	1	290263000	177,057
31	3	75	285	12	1	290263100	189,571
32	4	77	317	12	1	290263200	221,480
34	4	78	321	12	1	290263400	247,137
35	4	78	321	12	1	290263500	255,893
36	4	79	325	12	1	290263600	270,911
38	4	81	329	12	1	290263800	295,306
40	4	81	329	12	1	290264000	325,963
45	4	83	336	12	1	290264500	396,405
50	4	86	344	12	1	290265000	449,190



Per operazioni di finitura di fori passanti in tolleranza H7 di materiali ferrosi e non ferrosi. Suitable for finishing operations, inside through holes with H7 tolerance.

Spessore di sovrametallo consigliato. - Removable stock thickness

0,2 mm per alesatori con  $5 \leq d_1 \leq 11$  mm - for reamers  $5 \leq d_1 \leq 11$  mm

0,3 mm per alesatori con  $11 < d_1 \leq 38$  mm - for reamers  $11 < d_1 \leq 38$  mm

0,4 mm per alesatori con  $40 \leq d_1 \leq 50$  mm - for reamers  $40 \leq d_1 \leq 50$  mm

# 29040

## Alesatori a manicotto in HSS con taglienti elicoidali e foro conico 1:30

HSS shell reamers with taper bore 1:30 / Alésoirs creux à alesage conique 1:30 /

Escariadores huecos a maquina HSS conicidad 1:30 / Aufsteckreibahlen mit kegeliger Bohrung 1:30

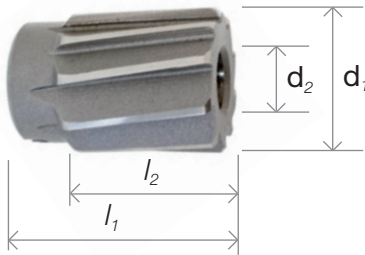

$d_1$	$d_2$	$l_2$	$l_1$	$z$	pcs	cod.	€ cad/each	$d_1$	$d_2$	$l_2$	$l_1$	$z$	pcs	cod.	€ cad/each
30	13,0	32	45	10	1	290403000	107,609	45	22,0	45	63	12	1	290404500	218,354
32	16,0	36	50	12	1	290403200	120,753	46	22,0	45	63	12	1	290404600	231,498
34	16,0	36	50	12	1	290403400	133,888	48	22,0	45	63	12	1	290404800	245,254
35	16,0	36	50	12	1	290403500	134,519	50	22,0	45	63	12	1	290405000	266,533
36	19,0	40	56	12	1	290403600	153,284	52	27,0	50	71	12	1	290405200	297,811
38	19,0	40	56	12	1	290403800	163,292	55	27,0	50	71	12	1	290405500	330,351
40	19,0	40	56	12	1	290404000	171,427	58	27,0	50	71	12	1	290405800	348,495
42	19,0	40	56	12	1	290404200	185,824	60	27,0	50	71	12	1	290406000	366,007

# 29041

## Mandrino porta alesatore a manicotto con estrattore

Drill chuck for shell reamers with ejecting tool

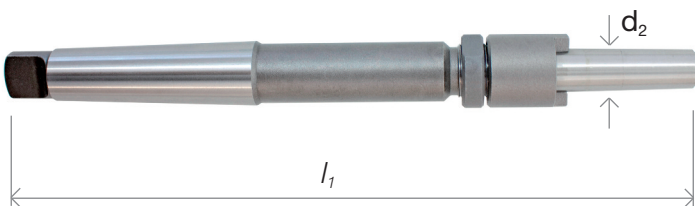
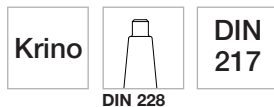

M.K.	$d_2$	$l_1$	cod.	€ cad/each
3	13	250	290410313	264,298
3	16	261	290410316	284,615
4	19	298	290410419	346,715
4	22	312	290410422	391,033
4	27	325	290410427	564,261

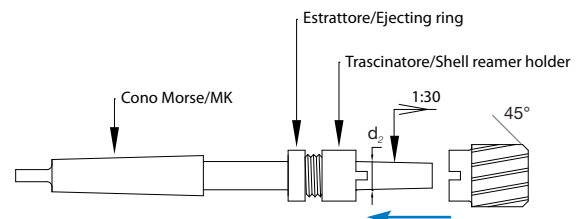

Per operazioni di finitura di fori passanti in tolleranza H7 di materiali ferrosi e non ferrosi. Da utilizzare con apposito mandrino porta alesatore. Suitable for finishing operations, inside through holes with H7 tolerance. Use with proper drill chuck.

Spessore di sovrametallo consigliato. - Removable stock thickness

0,3 mm per alesatori con  $30 \leq d_1 \leq 38$  mm - for reamers  $30 \leq d_1 \leq 38$  mm

0,4 mm per alesatori con  $40 \leq d_1 \leq 50$  mm - for reamers  $40 \leq d_1 \leq 50$  mm

## 29001

### Alesatori a mano in HSS a codolo cilindrico

HSS hand reamers / Alésours à main HSS

Escariadores a mano HSS / Handreibahlen HSS.

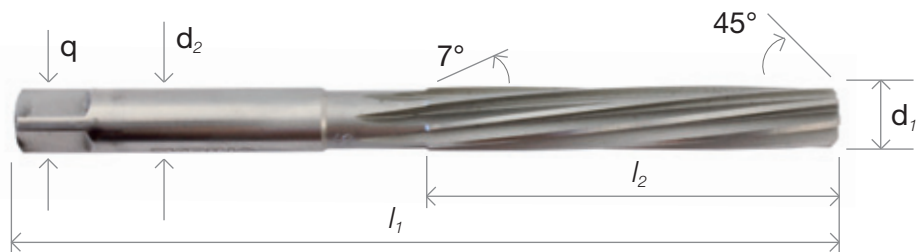

$d_1$	$d_2$	q	$l_2$	$l_1$	z	pcs 	cod.	€ cad/each
4	4	3,0	38	76	6	1	290010400	23,588
5	5	3,8	44	87	6	1	290010500	25,606
6	6	4,9	47	93	6	1	290010600	27,624
7	7	5,5	54	107	6	1	290010700	30,998
8	8	6,2	58	115	6	1	290010800	33,689
9	9	7,0	62	124	6	1	290010900	37,063
10	10	8,0	66	133	6	1	290011000	41,100
11	11	9,0	71	142	8	1	290011100	55,248
12	12	9,0	76	152	8	1	290011200	60,641
13	13	10,0	76	152	8	1	290011300	66,033
14	14	11,0	81	163	8	1	290011400	74,116
15	15	12,0	81	163	8	1	290011500	80,854
16	16	12,0	87	175	8	1	290011600	90,966
17	17	13,0	87	175	8	1	290011700	92,312
18	18	14,5	93	188	8	1	290011800	93,657
19	19	14,5	93	188	10	1	290011900	98,377
20	20	16,0	100	201	10	1	290012000	115,889
21	21	16,0	100	201	10	1	290012100	116,562
22	22	18,0	107	215	10	1	290012200	129,365
23	23	18,0	107	215	10	1	290012300	136,775
24	24	18,0	115	231	10	1	290012400	159,690
25	25	20,0	115	231	10	1	290012500	160,363
26	26	20,0	115	231	10	1	290012600	178,558
27	27	22,0	124	247	10	1	290012700	192,034
28	28	22,0	124	247	10	1	290012800	212,920
30	30	24,0	124	247	10	1	290013000	233,807
32	32	24,0	133	265	12	1	290013200	274,234
34	34	26,0	142	284	12	1	290013400	317,352
35	35	29,0	142	284	12	1	290013500	334,874
36	36	29,0	142	284	12	1	290013600	347,677
38	38	29,0	152	305	12	1	290013800	404,271
40	40	32,0	152	305	12	1	290014000	439,306



Per operazioni di finitura di fori passanti in tolleranza H7 di materiali ferrosi e non ferrosi. Suitable for finishing operations, inside through holes with H7 tolerance.

Spessore di sovrametallo consigliato. - Removable stock thickness

0,1 mm per alesatori con  $d_1 = 4$  mm - for reamers  $d_1 = 4$  mm

0,2 mm per alesatori con  $4 < d_1 \leq 11$  mm - for reamers  $4 < d_1 \leq 11$  mm

0,3 mm per alesatori con  $11 < d_1 \leq 38$  mm - for reamers  $11 < d_1 \leq 38$  mm

0,4 mm per alesatori con  $d_1 = 40$  mm - for reamers  $d_1 = 40$  mm

# 29010

## Alesatori a mano in HSS a codolo cilindrico, conicità 1:50, per fori di spine coniche

Taper pin hand reamers, taper 1:50 / Alésoirs à main pour trous de goupilles coniques, conicité 1:50

Escariadores a mano HSS, conicidad 1:50 / Handreibahlen für Kegelstiftbohrungen, Kegel 1:50

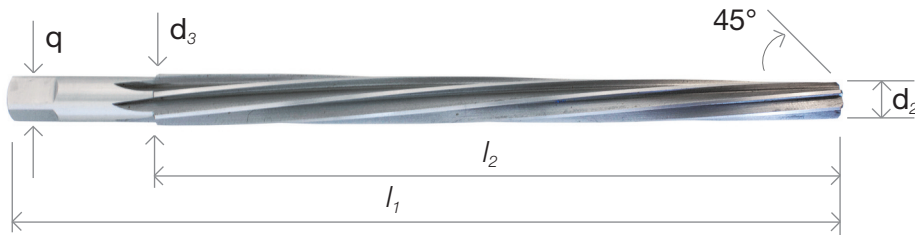
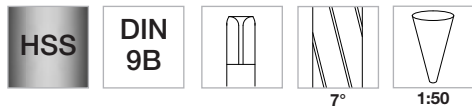

$d_1$	$d_2$	$d_3$	$q$	$l_2$	$l_1$	$z$	pcs 	cod.	€ cad/each
4	3,90	5,25	4,00	68	93	5	1	290100400	42,445
5	4,90	6,36	5,00	73	100	5	1	290100500	43,118
6	5,90	8,00	6,30	105	135	6	1	290100600	52,557
8	7,90	10,80	8,00	145	180	7	1	290100800	80,854
10	9,90	13,40	10,00	175	215	7	1	290101000	99,722
12	11,80	16,00	11,20	210	255	7	1	290101200	136,103
16	15,80	20,40	14,00	230	280	9	1	290101600	208,201
20	19,80	24,80	18,00	250	310	9	1	290102000	289,728



Per operazioni di alesatura in fori di spine coniche con tolleranza H7. Scaricare ripetutamente i trucioli durante la lavorazione. Suitable for reaming in taper pin holes with H7 tolerance. Please remove the chips while reaming.

Spessore di sovrametallo consigliato. - Removable stock thickness

0,1 mm per alesatori con  $d_1 = 4$  mm - for reamers  $d_1 = 4$  mm

0,2 mm per alesatori con  $4 < d_1 < 12$  mm - for reamers  $4 < d_1 < 12$  mm

0,3 mm per alesatori con  $12 \leq d_1 \leq 20$  mm - for reamers  $12 \leq d_1 \leq 20$  mm

## 29006

### Alesatori regolabili a mano a piccola espansione in HSS a codolo cilindrico

HSS adjustable hand reamers / Alésoirs à main réglables HSS /

Escariadores extensibles en HSS con guía / Handreibahnen mit verschiebbaren Messen

HSS  
CO5

DIN  
859/B



Espansione 1/100 del diametro nominale  
Adjustable hand reamer 1/100 nominal diameter

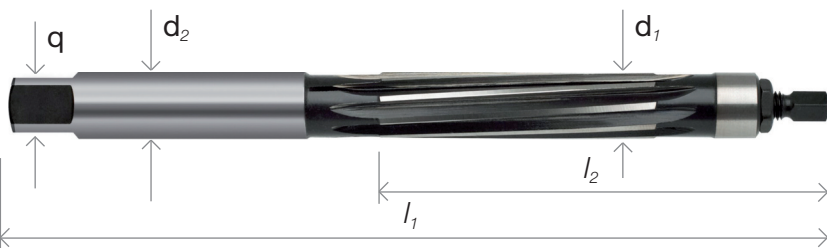

$d_1$	$d_2$ e9	q	$l_2$	$l_1$	z	pcs 	cod.	€ cad/each
4	4	3,0	24	76	6	1	29006001	119,284
5	5	3,8	30	87	6	1	29006002	120,629
6	6	4,9	33	93	6	1	29006003	121,716
7	7	5,5	38	107	9	1	29006004	148,419
8	8	6,2	42	115	9	1	29006005	146,970
9	9	7,0	46	124	9	1	29006006	157,372
10	10	8,0	50	133	9	1	29006007	162,599
11	11	9,0	51	142	9	1	29006008	193,804
12	12	9,0	56	152	9	1	29006009	183,557
13	13	10,0	56	152	9	1	29006010	211,813
14	14	11,0	61	163	9	1	29006011	217,712
15	15	12,0	61	163	9	1	29006012	228,735
16	16	12,0	67	175	9	1	29006013	284,418
19	19	14,5	68	188	9	1	29006014	301,496
20	20	16,0	75	201	9	1	29006015	310,448
22	22	18,0	82	215	12	1	29006016	370,582
24	24	18,0	85	231	12	1	29006017	407,790
25	25	20,0	85	231	12	1	29006018	408,101
30	30	24,0	94	247	12	1	29006019	527,747
33	33	26,0	99	265	12	1	29006020	382,484
38	38	29,0	111	305	12	1	29006021	1028,583

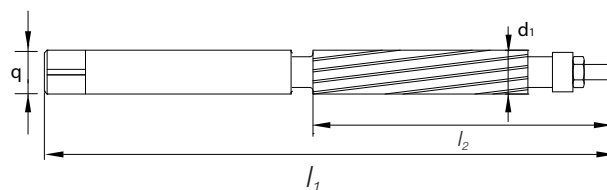
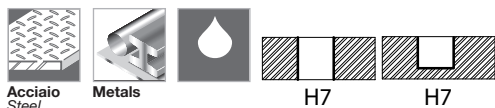

Per eseguire riparazioni e lavorazioni leggere in fori ciechi e/o passanti in tolleranza H7. Suitable for recovery and light works inside blind and/or through holes with H7 tolerance.

Spessore di sovrametallo consigliato. - Removable stock thickness

0,1 mm per alesatori con  $d_1 = 4$  mm - for reamers  $d_1 = 4$  mm

0,2 mm per alesatori con  $4 < d_1 \leq 11$  mm - for reamers  $4 < d_1 \leq 11$  mm

0,3 mm per alesatori con  $11 < d_1 \leq 38$  mm - for reamers  $11 < d_1 \leq 38$  mm

# 29005

## Alesatori regolabili a mano a grande espansione in HSS a codolo cilindrico

HSS adjustable hand reamers / Alésoirs à main réglables HSS /

Escariadores extensibles en HSS con guía / Handreibahlen mit verschiebbaren Messen



**Grande espansione, lame corte**  
Expanding hand reamer, short type

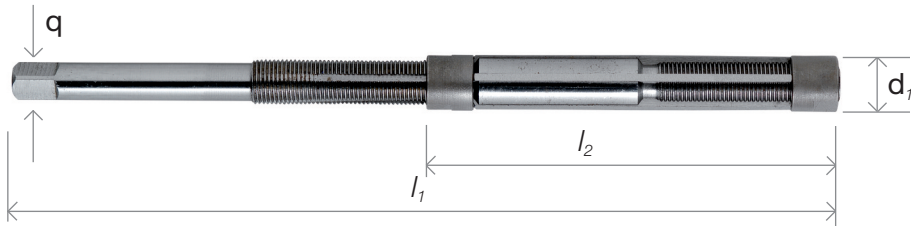

$d_1$	q	$l_2$	$l_1$	z	pcs 	cod.	€ cad/each
6,4-7,2	3,0	32	110	4	1	29005001	166,273
7,2-8	3,4	32	110	4	1	29005002	168,136
8-9	3,8	34	115	5	1	29005003	169,999
9-10	4,3	34	115	5	1	29005004	179,107
10-11	4,9	34	115	5	1	29005005	186,248
11-12	4,9	35	125	5	1	29005006	184,230
12-13,5	6,2	41	135	5	1	29005007	208,087
13,5-15,5	7,0	50	146	5	1	29005008	227,286
15,5-18	8,0	60	166	5	1	29005009	229,201
18-21	9,0	65	178	5	1	29005010	251,453
21-24	11,0	76	195	5	1	29005011	310,190
24-27,5	12,0	82	218	5	1	29005012	331,097
27,5-31,5	14,5	86	245	5	1	29005013	397,285
31,5-37	18,0	98	280	6	1	29005014	542,961
37-45	20,0	108	325	6	1	29005015	701,627
45-55	26,0	118	370	6	1	29005016	948,164
55-65	32,0	125	400	6	1	29005017	1261,562
67-80	39,0	140	435	8	1	29005018	1897,517

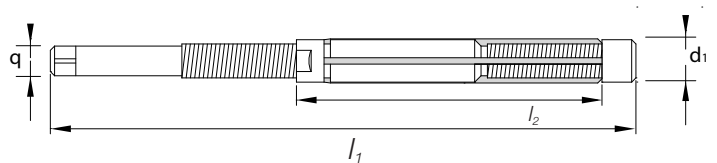

Per eseguire riparazioni e lavorazioni leggere in fori ciechi e/o passanti in tolleranza H7. Suitable for recovery and light works inside blind and/or through holes with H7 tolerance.

Spessore di sovrametallo consigliato. - Removable stock thickness

0,2 mm per alesatori con  $d_1 \leq 11$  mm - for reamers  $d_1 \leq 11$  mm

0,3 mm per alesatori con  $11 < d_1 \leq 38$  mm - for reamers  $11 < d_1 \leq 38$  mm

0,4 mm per alesatori con  $38 < d_1 \leq 50$  mm - for reamers  $38 < d_1 \leq 50$  mm



## > FRESE FRONTALI

End mills  
Fraises rainurer  
Fresas frontales  
Lan loch räser

Con questo capitolo, comprendente gli utensili per fresare, è quasi compiuta la gamma più importante degli utensili da taglio per asportazione di truciolo. Una particolare attenzione è stata dedicata alle frese frontali, nelle versioni in acciaio superrapido HSS-CO8% ed in metallo duro integrale di grande qualità, con e senza rivestimento, per operazioni di sgrossatura, finitura e superfinitura.

# CUTTING

## CUTTING TOOLS ENGINEERING

This chapter, which includes milling tools for all classes of steel, completes the wide range of chip removal tools presented in this new catalogue. Special attention was given to the section relating to frontal burrs in HSS-CO8% steel, also with TiAlN surface coating, and in high-quality carbide for the roughing, finishing and super-finishing operations.

Ce chapitre, qui comprend les outils pour afraiser différentes classes d'acier, nous permet de compléter l'importante gamme d'outils de découpe pour l'enlèvement des copeaux présentée dans ce nouveau catalogue. Une attention particulière a été dédiée à la section des fraises frontales dans les versions en acier super rapide HSS-CO8%, présentées aussi avec le revêtement de surface TiAlN, et en métal dur intégral de grande qualité pour les opérations de dégrossissage, finition et superfinition.

Con este apartado, que incluye los utensilios para fresar en diferentes tipos de acero, completamos ulteriormente la importante gama de utensilios de corte para eliminar virutas, ilustrada en este nuevo catálogo. Se ha dedicado una atención especial a la sección de fresas frontales, en las versiones de acero super rápido HSS-CO8%, presentadas también con revestimiento superficial TiAlN, y de metal duro integral de gran calidad para operaciones de desbaste, acabado y superacabado.



## 24013

### Frese frontali cilindriche a 4 taglienti in HSS-CO8% con attacco Weldon

HSS-CO8% four flutes end mills, Weldon shank / Fraises à rainurer HSS-CO8%, quatre dents, queue Weldon /

Fresas frontales HSS-CO8%, mango Weldon / Vierschneider Langlochfräser

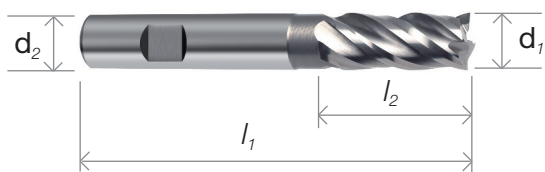

$d_1$ k10	$d_2$	$l_1$	$l_2$	Z	pcs 	cod.	€ cad/each
3	6	52	8	4	1	240130300	16,105
4	6	55	11	4	1	240130400	16,105
5	6	57	13	4	1	240130500	16,105
6	6	57	13	4	1	240130600	16,105
7	10	66	16	4	1	240130700	23,515
8	10	69	19	4	1	240130800	21,859
9	10	69	19	4	1	240130900	23,515
10	10	72	22	4	1	240131000	21,859
12	12	83	26	4	1	240131200	30,512
14	12	83	26	4	1	240131400	33,586
16	16	92	32	4	1	240131600	41,100
18	16	92	32	4	1	240131800	50,839
20	20	104	38	4	1	240132000	60,682
22	20	104	38	6	1	240132200	67,689

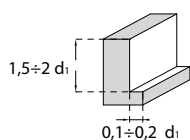

Operazione consigliata / Working tips

Fresa univesale per operazioni di finitura  
Universal end mill for finishing purpose



Acciai e metalli con  $R < 850 \text{ N/mm}^2$ , alluminio con Si 3÷12%, ghisa con durezza HB30<200. Steel and metals with  $R < 850 \text{ N/mm}^2$ , aluminium with Si 3÷12%, cast iron with HB30<200 / Métaux et acier avec  $R < 850 \text{ N/mm}^2$ , aluminium avec Si 3÷12%, fonte HB30<200 / Metales e acero con  $R < 850 \text{ N/mm}^2$ , aluminio con Si 3÷12%, fundición HB30<200.

# 24015

## Frese frontali cilindriche a 4 taglienti in HSS-CO8% con attacco Weldon

HSS-CO8% four flutes end mills, Weldon shank / Fraises à rainurer HSS-CO8%, quatre dents, queue Weldon /

Fresas frontales HSS-CO8%, mango Weldon / Vierschneider Langlochfräser

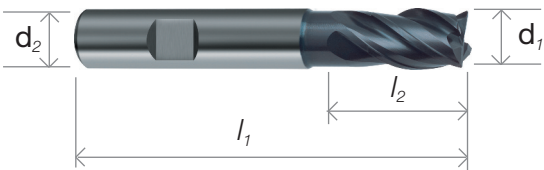

$d_1$ k10	$d_2$	$l_1$	$l_2$	Z	pcs 	cod.	€ cad/each
3	6	52	8	4	1	240150300	24,592
4	6	55	11	4	1	240150400	23,401
5	6	57	13	4	1	240150500	23,401
6	6	57	13	4	1	240150600	23,225
7	10	66	16	4	1	240150700	31,940
8	10	69	19	4	1	240150800	30,512
9	10	69	19	4	1	240150900	31,712
10	10	72	22	4	1	240151000	30,574
12	12	83	26	4	1	240151200	40,479
14	12	83	26	4	1	240151400	44,174
16	16	92	32	4	1	240151600	60,061
18	16	92	32	4	1	240151800	72,243
20	20	104	38	4	1	240152000	81,806
22	20	104	38	6	1	240152200	90,345

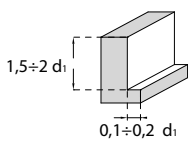

Operazione consigliata / Working tips

Fresa univesale per operazioni di finitura  
Universal end mill for finishing purpose

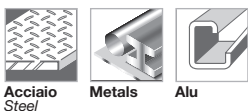

Acciai e metalli con  $R < 850 \text{ N/mm}^2$ , alluminio con  $\text{Si } 3\pm 12\%$ , ghisa con durezza  $\text{HB}30 < 200$ . Steel and metals with  $R < 850 \text{ N/mm}^2$ , aluminium with  $\text{Si } 3\pm 12\%$ , cast iron with  $\text{HB}30 < 200$  / Métaux et acier avec  $R < 850 \text{ N/mm}^2$ , aluminium avec  $\text{Si } 3\pm 12\%$ , fonte  $\text{HB}30 < 200$  / Metales e acero con  $R < 850 \text{ N/mm}^2$ , aluminio con  $\text{Si } 3\pm 12\%$ , fundición  $\text{HB}30 < 200$ .

## 24014

### Frese frontali cilindriche a 4 taglienti in HSS-CO8% con attacco Weldon, serie lunga

HSS-CO8% four flutes end mills, Weldon shank / Fraises à rainurer HSS-CO8%, quatre dents, queue Weldon /

Fresas frontales HSS-CO8%, mango Weldon / Vierschneider Langlochfräser

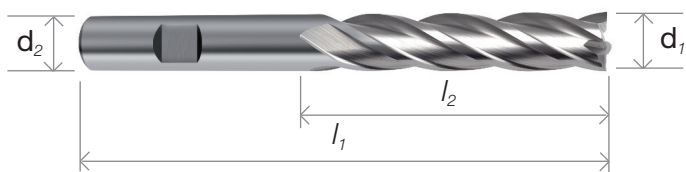
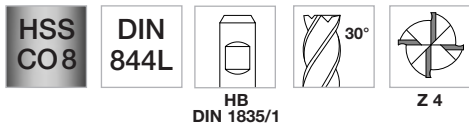

$d_1$ k10	$d_2$	$l_1$	$l_2$	Z	pcs 	cod.	€ cad/each
4	4	63	19	4	1	240140400	20,948
5	5	68	24	4	1	240140500	20,948
6	6	68	24	4	1	240140600	20,948
8	8	88	38	4	1	240140800	29,487
10	10	95	45	4	1	240141000	29,487
12	12	110	53	4	1	240141200	41,162
14	14	110	53	4	1	240141400	47,082
16	16	123	63	4	1	240141600	57,494
18	18	123	63	4	1	240141800	71,156
20	20	141	75	4	1	240142000	84,880

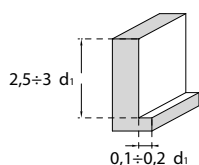

Operazione consigliata / Working tips

Fresa univesale per operazioni di finitura  
Universal end mill for finishing purpose



Acciai e metalli con  $R < 850 \text{ N/mm}^2$ , alluminio con  $\text{Si } 3\div 12\%$ , ghisa con durezza  $\text{HB}30 < 200$ . Steel and metals with  $R < 850 \text{ N/mm}^2$ , aluminium with  $\text{Si } 3\div 12\%$ , cast iron with  $\text{HB}30 < 200$  / Métaux et acier avec  $R < 850 \text{ N/mm}^2$ , aluminium avec  $\text{Si } 3\div 12\%$ , fonte  $\text{HB}30 < 200$  / Metales e acero con  $R < 850 \text{ N/mm}^2$ , aluminio con  $\text{Si } 3\div 12\%$ , fundición  $\text{HB}30 < 200$ .

# 24016

## Frese frontali cilindriche a 4 taglienti in HSS-CO8% con attacco Weldon, serie lunga

HSS-CO8% four flutes end mills, Weldon shank / Fraises à rainurer HSS-CO8%, quatre dents, queue Weldon /

Fresas frontales HSS-CO8%, mango Weldon / Vierschneider Langlochfräser

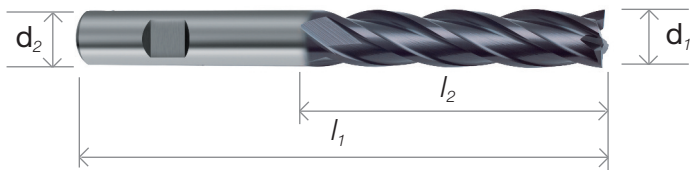
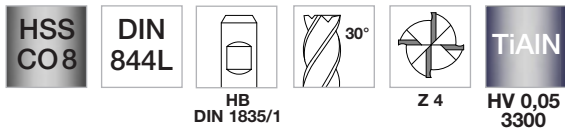

$d_1$ k10	$d_2$	$l_1$	$l_2$	Z	pcs 	cod.	€ cad/each
4	4	63	19	4	1	240160400	30,056
5	5	68	24	4	1	240160500	29,549
6	6	68	24	4	1	240160600	28,349
8	8	88	38	4	1	240160800	38,367
10	10	95	45	4	1	240161000	39,620
12	12	110	53	4	1	240161200	53,396
14	14	110	53	4	1	240161400	60,744
16	16	123	63	4	1	240161600	80,213
18	18	123	63	4	1	240161800	95,468
20	20	141	75	4	1	240162000	106,740

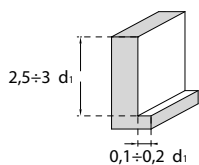

Operazione consigliata / Working tips

Fresa univesale per operazioni di finitura  
Universal end mill for finishing purpose

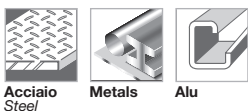

Acciai e metalli con  $R < 850 \text{ N/mm}^2$ , alluminio con Si 3÷12%, ghisa con durezza HB30<200. Steel and metals with  $R < 850 \text{ N/mm}^2$ , aluminium with Si 3÷12%, cast iron with HB30<200 / Métaux et acier avec  $R < 850 \text{ N/mm}^2$ , aluminium avec Si 3÷12%, fonte HB30<200 / Metales e acero con  $R < 850 \text{ N/mm}^2$ , aluminio con Si 3÷12%, fundición HB30<200.

## 24017

### Frese frontali cilindriche a 4 taglienti a sgrossare in HSS-CO8% con attacco Weldon

HSS-CO8% four flutes end mills, Weldon shank for roughing purpose / Fraises à rainurer HSS-CO8% pour dégrossissage, quatre dents, queue Weldon / Fresas frontales HSS-CO8%, mango Weldon / Vierischneider Langlochfräser

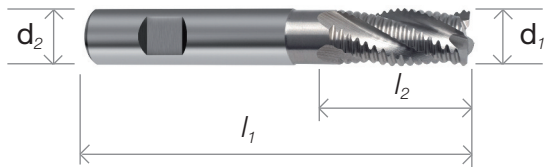
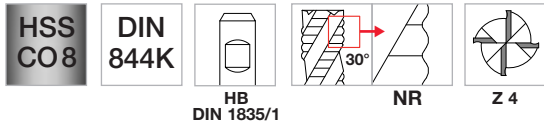

$d_1$ k12	$d_2$	$l_1$	$l_2$	Z	pcs 	cod.	€ cad/each
6	6	57	13	4	1	240170600	36,660
8	10	69	19	4	1	240170800	41,504
10	10	72	22	4	1	240171000	41,504
12	12	79	22	4	1	240171200	51,005
14	12	83	26	4	1	240171400	58,860
16	16	92	32	4	1	240171600	66,602
18	16	92	32	4	1	240171800	74,748
20	20	104	38	4	1	240172000	94,558

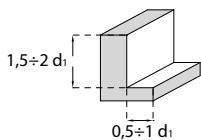

Operazione consigliata / Working tips

Fresa univesale per operazioni di sgrossatura  
Universal end mill for roughing purpose

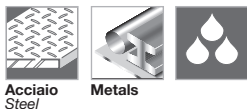

Acciai e metalli con  $R < 850 \text{ N/mm}^2$ , ghisa con durezza  $HB30 < 200$ , acciai molto duri con  $R < 1000 \text{ N/mm}^2$ . Steel and metals with  $R < 850 \text{ N/mm}^2$ , cast iron with  $HB30 < 200$ , hard steel with  $R < 1000 \text{ N/mm}^2$  / Métaux et acier avec  $R < 850 \text{ N/mm}^2$ , fonte  $HB30 < 200$ , aciers durs avec  $R < 1000 \text{ N/mm}^2$  / Metales e acero con  $R < 850 \text{ N/mm}^2$ , fundición  $HB30 < 200$ , aceros duros  $R < 1000 \text{ N/mm}^2$ .

# 24019

## Frese frontali cilindriche a 4 taglienti a sgrossare in HSS-CO8% con attacco Weldon

HSS-CO8% four flutes end mills, Weldon shank for roughing purpose / Fraises à rainurer HSS-CO8% pour dégrossissage, quatre dents, queue Weldon / Fresas frontales HSS-CO8%, mango Weldon / Vierischneider Langlochfräser

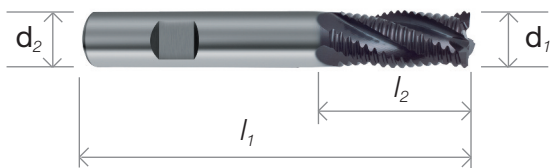
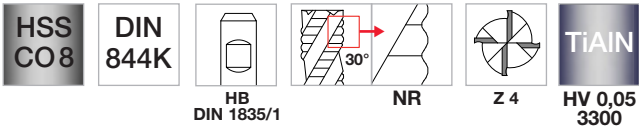

$d_1$ k12	$d_2$	$l_1$	$l_2$	Z	pcs 	cod.	€ cad/each
6	6	57	13	4	1	240190600	42,808
8	10	69	19	4	1	240190800	49,297
10	10	72	22	4	1	240191000	59,720
12	12	79	22	4	1	240191200	59,720
14	12	83	26	4	1	240191400	68,258
16	16	92	32	4	1	240191600	84,880
18	16	92	32	4	1	240191800	92,850
20	20	104	38	4	1	240192000	114,419

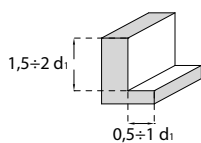

Operazione consigliata / Working tips

Fresa univesale per operazioni di sgrossatura  
Universal end mill for roughing purpose

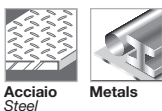

Acciai e metalli con  $R < 850 \text{ N/mm}^2$ , ghisa con durezza  $HB30 < 200$ , acciai molto duri con  $R < 1000 \text{ N/mm}^2$ . Steel and metals with  $R < 850 \text{ N/mm}^2$ , cast iron with  $HB30 < 200$ , hard steel with  $R < 1000 \text{ N/mm}^2$  / Métaux et acier avec  $R < 850 \text{ N/mm}^2$ , fonte  $HB30 < 200$ , aciers durs avec  $R < 1000 \text{ N/mm}^2$  / Metales e acero con  $R < 850 \text{ N/mm}^2$ , fundición  $HB30 < 200$ , aceros duros  $R < 1000 \text{ N/mm}^2$ .

## 24018

Frese frontali cilindriche a 4 taglienti a sgrossare in HSS-CO8% con attacco Weldon, serie lunga

HSS-CO8% four flutes end mills, Weldon shank / Fraises à rainurer HSS-CO8%, quatre dents, queue Weldon /

Fresas frontales HSS-CO8%, mango Weldon / Vierschneider Langlochfräser

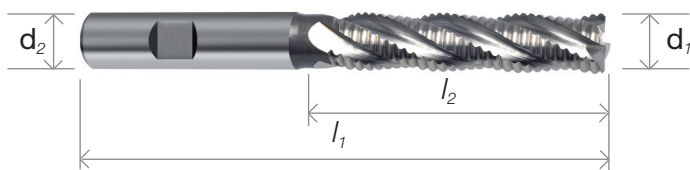
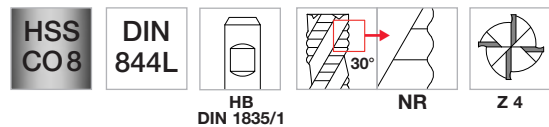

$d_1$ k12	$d_2$	$l_1$	$l_2$	Z	pcs 	cod.	€ cad/each
6	6	68	24	4	1	240180600	49,525
8	10	88	38	4	1	240180800	52,940
10	10	95	45	4	1	240181000	54,306
12	12	110	53	4	1	240181200	72,357
14	12	110	53	4	1	240181400	72,522
16	16	123	63	4	1	240181600	91,194
18	16	123	63	4	1	240181800	110,321
20	20	141	75	4	1	240182000	124,614
22	20	141	75	4	1	240182200	221,956
25	25	166	90	4	1	240182500	264,360
28	25	166	90	4	1	240182800	303,472

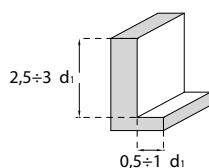

Operazione consigliata / Working tips

Fresa univesale per operazioni di sgrossatura  
Universal end mill for roughing purpose

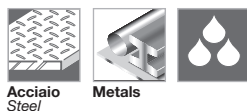

Acciai e metalli con  $R < 850 \text{ N/mm}^2$ , ghisa con durezza  $\text{HB}_{30} < 200$ , acciai molto duri con  $R < 1000 \text{ N/mm}^2$ . Steel and metals with  $R < 850 \text{ N/mm}^2$ , cast iron with  $\text{HB}_{30} < 200$ , hard steel with  $R < 1000 \text{ N/mm}^2$  / Métaux et acier avec  $R < 850 \text{ N/mm}^2$ , fonte  $\text{HB}_{30} < 200$ , aciers durs avec  $R < 1000 \text{ N/mm}^2$  / Metales e acero con  $R < 850 \text{ N/mm}^2$ , fundición  $\text{HB}_{30} < 200$ , aceros duros  $R < 1000 \text{ N/mm}^2$ .

# 24020

Frese frontali cilindriche a 4 taglienti a sgrossare in HSS-CO8% con attacco Weldon, serie lunga

HSS-CO8% four flutes end mills, Weldon shank / Fraises à rainurer HSS-CO8%, quatre dents, queue Weldon /

Fresas frontales HSS-CO8%, mango Weldon / Vierschneider Langlochfräser

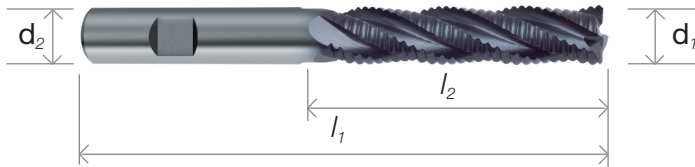
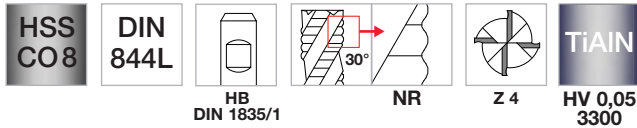

$d_1$ k12	$d_2$	$l_1$	$l_2$	Z	pcs 	cod.	€ cad/each
6	6	68	24	4	1	240200600	57,898
8	10	88	38	4	1	240200800	64,211
10	10	95	45	4	1	240201000	64,387
12	12	110	53	4	1	240201200	88,917
14	12	110	53	4	1	240201400	86,184
16	16	123	63	4	1	240201600	113,053
18	16	123	63	4	1	240201800	133,318
20	20	141	75	4	1	240202000	149,547
22	20	141	75	4	1	240202200	250,988
25	25	166	90	4	1	240202500	309,051
28	25	166	90	4	1	240202800	350,379

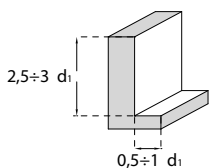

Operazione consigliata / Working tips

Fresa univesale per operazioni di sgrossatura  
Universal end mill for roughing purpose

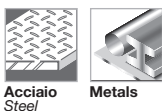

Acciai e metalli con  $R < 850 \text{ N/mm}^2$ , ghisa con durezza  $HB30 < 200$ , acciai molto duri con  $R < 1000 \text{ N/mm}^2$ . Steel and metals with  $R < 850 \text{ N/mm}^2$ , cast iron with  $HB30 < 200$ , hard steel with  $R < 1000 \text{ N/mm}^2$  / Métaux et acier avec  $R < 850 \text{ N/mm}^2$ , fonte  $HB30 < 200$ , aciers durs avec  $R < 1000 \text{ N/mm}^2$  / Metales e acero con  $R < 850 \text{ N/mm}^2$ , fundición  $HB30 < 200$ , aceros duros  $R < 1000 \text{ N/mm}^2$ .



## 24021

### Frese frontali cil. a 4 taglienti per semifinitura in HSS-CO8% con attacco Weldon

HSS-CO8% four flutes end mills, Weldon shank for finishing purpose / Fraises à rainurer HSS-CO8% pour semi-finissage, quatre dents, queue Weldon / Fresas frontales HSS-CO8%, mango Weldon / Mierschneider Langlochfräser

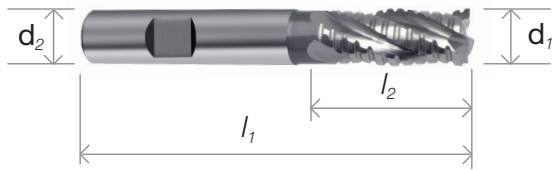
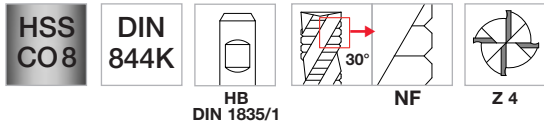

$d_1$ k12	$d_2$	$l_1$	$l_2$	Z	pcs 	cod.	€ cad/each
6	6	57	13	4	1	240210600	52,713
8	10	69	19	4	1	240210800	55,507
10	10	72	22	4	1	240211000	68,258
12	12	83	26	4	1	240211200	75,596
14	12	83	26	4	1	240211400	90,511
16	16	92	32	4	1	240211600	103,779
18	16	92	32	4	1	240211800	109,586
20	20	104	38	4	1	240212000	124,780

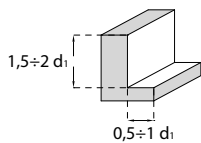

Operazione consigliata / Working tips

Fresa univesale per operazioni di semifinitura  
Universal end mill for semifinishing purpose

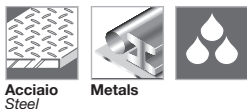

Acciai e metalli con  $R < 850 \text{ N/mm}^2$ , ghisa con durezza  $HB30 < 200$ , acciai molto duri con  $R < 1000 \text{ N/mm}^2$ . Steel and metals with  $R < 850 \text{ N/mm}^2$ , cast iron with  $HB30 < 200$ , hard steel with  $R < 1000 \text{ N/mm}^2$  / Métaux et acier avec  $R < 850 \text{ N/mm}^2$ , fonte  $HB30 < 200$ , aciers durs avec  $R < 1000 \text{ N/mm}^2$  / Metales e acero con  $R < 850 \text{ N/mm}^2$ , fundición  $HB30 < 200$ , aceros duros  $R < 1000 \text{ N/mm}^2$ .

# 24023

## Frese frontali cil. a 4 taglienti per semifinitura in HSS-CO8% con attacco Weldon

HSS-CO8% four flutes end mills, Weldon shank for finishing purpose / Fraises à rainurer HSS-CO8% pour semi-finissage, quatre dents, queue Weldon / Fresas frontales HSS-CO8%, mango Weldon / Mierschneider Langlochfräser

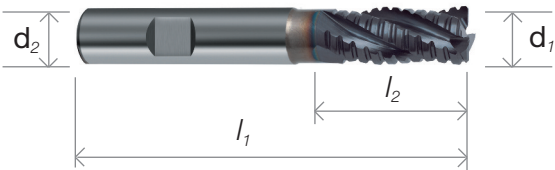
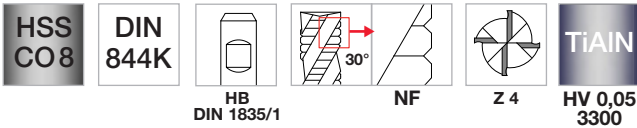

$d_1$ k12	$d_2$	$l_1$	$l_2$	Z	pcs 	cod.	€ cad/each
6	6	57	13	4	1	240230600	59,720
8	10	69	19	4	1	240230800	64,160
10	10	72	22	4	1	240231000	76,849
12	12	83	26	4	1	240231200	84,539
14	12	83	26	4	1	240231400	100,022
16	16	92	32	4	1	240231600	123,072
18	16	92	32	4	1	240231800	130,762
20	20	104	38	4	1	240232000	145,500

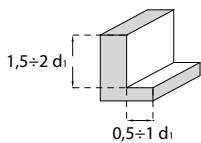

Operazione consigliata / Working tips

Fresa univesale per operazioni di semifinitura  
Universal end mill for semifinishing purpose

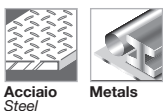

Acciai e metalli con  $R < 850 \text{ N/mm}^2$ , ghisa con durezza  $HB30 < 200$ , acciai molto duri con  $R < 1000 \text{ N/mm}^2$ . Steel and metals with  $R < 850 \text{ N/mm}^2$ , cast iron with  $HB30 < 200$ , hard steel with  $R < 1000 \text{ N/mm}^2$  / Métaux et acier avec  $R < 850 \text{ N/mm}^2$ , fonte  $HB30 < 200$ , aciers durs avec  $R < 1000 \text{ N/mm}^2$  / Metales e acero con  $R < 850 \text{ N/mm}^2$ , fundición  $HB30 < 200$ , aceros duros  $R < 1000 \text{ N/mm}^2$ .

## 24022

Frese frontali cil. a 4 taglienti per semifinitura in HSS-CO8% con attacco Weldon, serie lunga  
 HSS-CO8% four flutes end mills, Weldon shank for finishing purpose / Fraises à rainurer HSS-CO8% pour semi-finissage, quatre dents, queue Weldon  
 Fresas frontales HSS-CO8%, mango Weldon / Vierschneider Langlochfräser

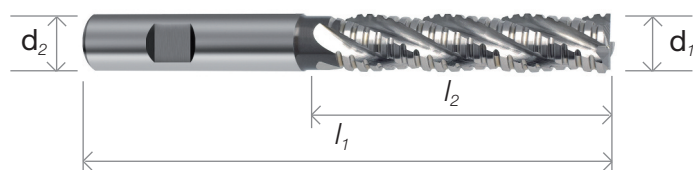
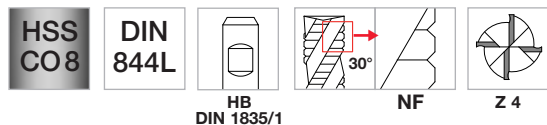

$d_1$ k12	$d_2$	$l_1$	$l_2$	Z	pcs 	cod.	€ cad/each
6	6	68	24	4	1	240220600	66,375
8	10	88	38	4	1	240220800	70,877
10	10	95	45	4	1	240221000	79,923
12	12	110	53	4	1	240221200	105,146
14	12	110	53	4	1	240221400	116,469
16	16	123	63	4	1	240221600	137,821
18	16	123	63	4	1	240221800	142,768
20	20	141	75	4	1	240222000	167,701
22	20	141	75	4	1	240222200	430,871
25	25	166	90	4	1	240222500	594,473
28	25	166	90	4	1	240222800	686,516

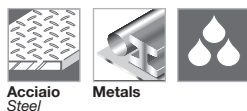
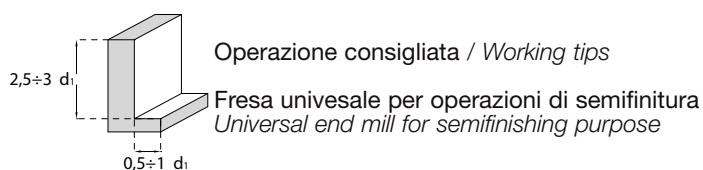

Acciai e metalli con R<850 N/mm<sup>2</sup>, ghisa con durezza HB30<200, acciai molto duri con R<1000 N/mm<sup>2</sup>. Steel and metals with R<850 N/mm<sup>2</sup>, cast iron with HB30<200, hard steel with R<1000 N/mm<sup>2</sup> / Métaux et acier avec R<850 N/mm<sup>2</sup>, fonte HB30<200, aciers durs avec R<1000 N/mm<sup>2</sup> / Metales e acero con R<850 N/mm<sup>2</sup>, fundición HB30<200, aceros duros R<1000 N/mm<sup>2</sup>.

# 24024

Frese frontali cil. a 4 taglienti per semifinitura in HSS-CO8% con attacco Weldon, serie lunga  
 HSS-CO8% four flutes end mills, Weldon shank for finishing purpose / Fraises à rainurer HSS-CO8% pour semi-finissage, quatre dents, queue  
 Weldon / Fresas frontales HSS-CO8%, mango Weldon / Mierschneider Langlochfräser

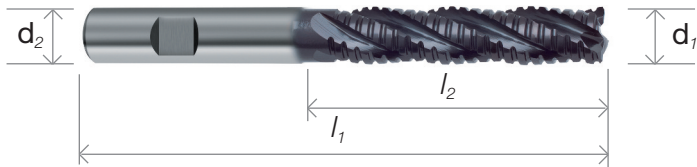
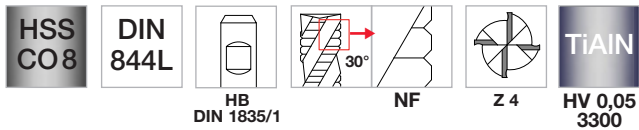

$d_1$ k12	$d_2$	$l_1$	$l_2$	Z	pcs 	cod.	€ cad/each
6	6	68	24	4	1	240240600	73,951
8	10	88	38	4	1	240240800	79,871
10	10	95	45	4	1	240241000	89,145
12	12	110	53	4	1	240241200	118,011
14	12	110	53	4	1	240241400	130,307
16	16	123	63	4	1	240241600	159,504
18	16	123	63	4	1	240241800	164,803
20	20	141	75	4	1	240242000	191,216
22	20	141	75	4	1	240242200	454,375
25	25	166	90	4	1	240242500	642,404
28	25	166	90	4	1	240242800	716,686

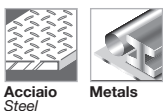
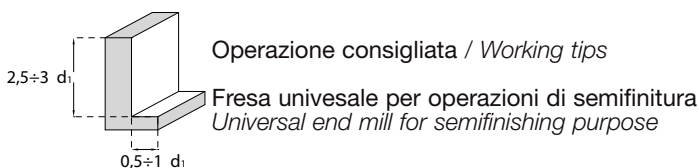

Acciai e metalli con  $R < 850 \text{ N/mm}^2$ , ghisa con durezza  $HB30 < 200$ , acciai molto duri con  $R < 1000 \text{ N/mm}^2$ . Steel and metals with  $R < 850 \text{ N/mm}^2$ , cast iron with  $HB30 < 200$ , hard steel with  $R < 1000 \text{ N/mm}^2$  / Métaux et acier avec  $R < 850 \text{ N/mm}^2$ , fonte  $HB30 < 200$ , aciers durs avec  $R < 1000 \text{ N/mm}^2$  / Metales e acero con  $R < 850 \text{ N/mm}^2$ , fundición  $HB30 < 200$ , aceros duros  $R < 1000 \text{ N/mm}^2$ .

## 24009

### Frese frontali cilindriche a 3 taglienti in HSS-CO8% con attacco Weldon

HSS-CO8% three flutes end mills, Weldon shank / Fraises à rainurer HSS-CO8%, trois dents, queue Weldon

Fresas frontales HSS-CO8%, mango Weldon / Dreischneider Langlochfräser

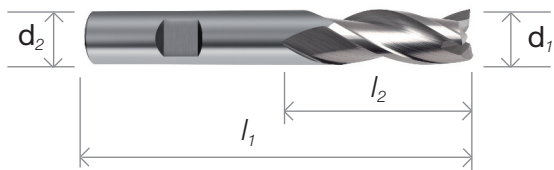

$d_1$ e8	$d_2$	$l_1$	$l_2$	Z	pcs 	cod.	€ cad/each
3	6	52	8	3	1	240090300	15,525
4	6	55	11	3	1	240090400	15,525
5	6	57	13	3	1	240090500	15,525
6	6	57	13	3	1	240090600	16,115
8	10	69	19	3	1	240090800	21,859
10	10	72	22	3	1	240091000	21,859
12	12	79	22	3	1	240091200	29,032
14	12	83	26	3	1	240091400	32,054
16	16	92	32	3	1	240091600	39,164
18	16	92	32	3	1	240091800	48,386
20	20	104	38	3	1	240092000	57,722

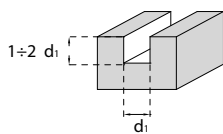

Operazione consigliata / Working tips

Fresa per cave  
Slot end mills

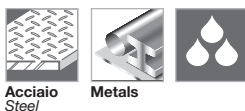

Acciai e metalli con R<850 N/mm<sup>2</sup>. Steel and metals with R<850 N/mm<sup>2</sup> / Métaux et acier avec R<850 N/mm<sup>2</sup> / Metales e acero con R<850 N/mm<sup>2</sup>.

# 24011

## Frese frontali cilindriche a 3 taglienti in HSS-CO8% con attacco Weldon

HSS-CO8% three flutes end mills, Weldon shank / Fraises à rainurer HSS-CO8%, trois dents, queue Weldon

Fresas frontales HSS-CO8%, mango Weldon / Dreischneider Langlochfräser

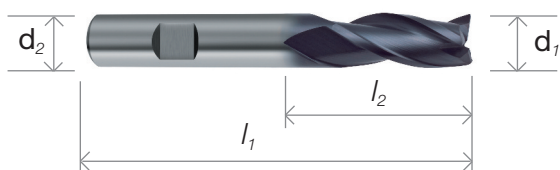
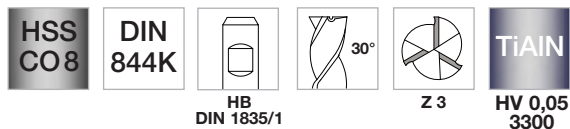

$d_1$ e8	$d_2$	$l_1$	$l_2$	Z	pcs 	cod.	€ cad/each
3	6	52	8	3	1	240110300	20,835
4	6	55	11	3	1	240110400	20,835
5	6	57	13	3	1	240110500	20,835
6	6	57	13	3	1	240110600	20,835
8	10	69	19	3	1	240110800	27,158
10	10	72	22	3	1	240111000	27,438
12	12	79	22	3	1	240111200	34,838
14	12	83	26	3	1	240111400	39,227
16	16	92	32	3	1	240111600	47,475
18	16	92	32	3	1	240111800	59,036
20	20	104	38	3	1	240112000	68,941

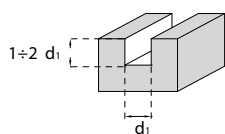

Operazione consigliata / Working tips

Fresa per cave  
Slot end mills

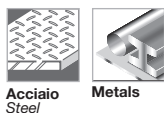

Acciai e metalli con  $R < 850 \text{ N/mm}^2$ . Steel and metals with  $R < 850 \text{ N/mm}^2$  / Métaux et acier avec  $R < 850 \text{ N/mm}^2$  / Metales e acero con  $R < 850 \text{ N/mm}^2$ .

## 24010

Frese frontali cilindriche a 3 taglienti in HSS-CO8% con attacco Weldon, serie lunga

HSS-CO8% three flutes end mills, Weldon shank / Fraises à rainurer HSS-CO8%, trois dents, queue Weldon

Fresas frontales HSS-CO8%, mango Weldon / Dreischneider Langlochfräser

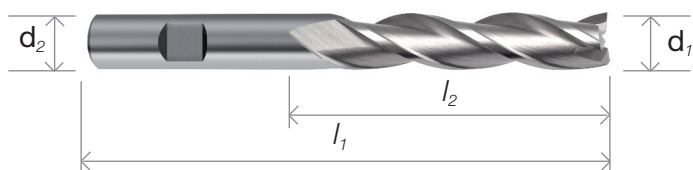
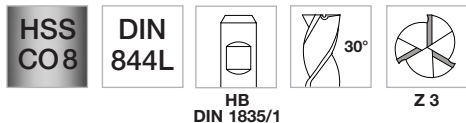

$d_1$ h10	$d_2$	$l_1$	$l_2$	Z	pcs 	cod.	€ cad/each
3	6	56	12	3	1	240100300	24,840
4	6	63	19	3	1	240100400	24,840
5	6	68	24	3	1	240100500	24,840
6	6	68	24	3	1	240100600	20,948
8	10	88	38	3	1	240100800	29,487
10	10	95	45	3	1	240101000	29,487
12	12	110	53	3	1	240101200	39,164
14	12	110	53	3	1	240101400	44,805
16	16	123	63	3	1	240101600	54,762
18	16	123	63	3	1	240101800	67,741
20	20	141	75	3	1	240102000	80,895

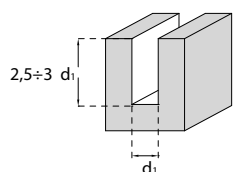

Operazione consigliata / Working tips

Fresa per cave  
Slot end mills

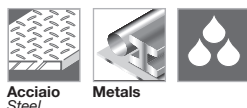

Acciai e metalli con R<850 N/mm<sup>2</sup>. Steel and metals with R<850 N/mm<sup>2</sup> / Métaux et acier avec R<850 N/mm<sup>2</sup> / Metales e acero con R<850 N/mm<sup>2</sup>.

# 24012

## Frese frontali cilindriche a 3 taglianti in HSS-CO8% con attacco Weldon, serie lunga

HSS-CO8% three flutes end mills, Weldon shank / Fraises à rainurer HSS-CO8%, trois dents, queue Weldon

Fresas frontales HSS-CO8%, mango Weldon / Dreischneider Langlochfräser

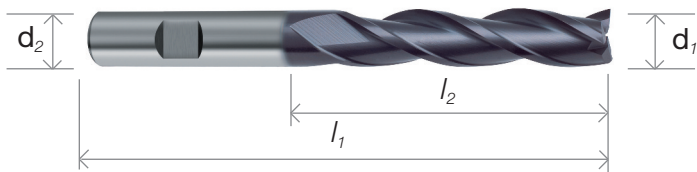

$d_1$ h10	$d_2$	$l_1$	$l_2$	Z	pcs 	cod.	€ cad/each
3	6	56	12	3	1	240120300	29,829
4	6	63	19	3	1	240120400	29,829
5	6	68	24	3	1	240120500	29,829
6	6	68	24	3	1	240120600	29,829
8	10	88	38	3	1	240120800	38,088
10	10	95	45	3	1	240121000	39,227
12	12	110	53	3	1	240121200	52,092
14	12	110	53	3	1	240121400	60,061
16	16	123	63	3	1	240121600	77,873
18	16	123	63	3	1	240121800	89,662
20	20	141	75	3	1	240122000	106,222

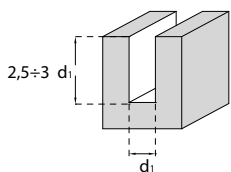

Operazione consigliata / Working tips

Fresa per cave  
Slot end mills

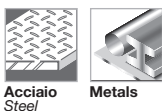

Acciai e metalli con  $R < 850 \text{ N/mm}^2$ . Steel and metals with  $R < 850 \text{ N/mm}^2$  / Métaux et acier avec  $R < 850 \text{ N/mm}^2$  / Metales e acero con  $R < 850 \text{ N/mm}^2$ .



## 24001

### Frese frontali cilindriche a 2 taglienti in HSS-CO8% con attacco Weldon

HSS-CO8% two flutes end mills, Weldon shank / Fraises à rainurer HSS-CO8%, deux dents, queue Weldon

Fresas frontales HSS-CO8%, mango Weldon / Zweischneider Langlochfräser

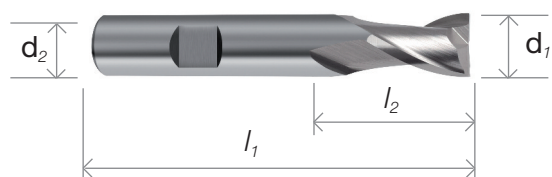
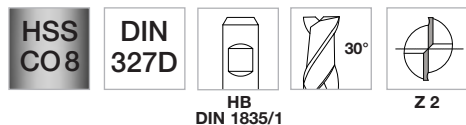

$d_1$	tol.	$d_2$	$l_1$	$l_2$	z	pcs	cod.	€ cad/each
2	e8	6	48	4	2	1	240010200	12,927
2,5	e8	6	49	5	2	1	240010250	13,952
3	e8	6	49	5	2	1	240010300	12,927
3,5	h10	6	51	7	2	1	240010350	13,890
4	e8	6	51	7	2	1	240010400	12,927
4,5	h10	6	52	8	2	1	240010450	13,890
5	e8	6	52	8	2	1	240010500	12,927
5,5	h10	6	52	8	2	1	240010550	13,890
6	e8	6	52	8	2	1	240010600	12,927
6,5	h10	10	60	10	2	1	240010650	19,986
7	e8	10	60	10	2	1	240010700	19,986
7,5	h10	10	61	11	2	1	240010750	19,986
8	e8	10	61	11	2	1	240010800	18,558
8,5	h10	10	61	11	2	1	240010850	19,986
9	h10	10	61	11	2	1	240010900	19,986
9,5	h10	10	63	13	2	1	240010950	19,986
10	e8	10	63	13	2	1	240011000	18,558
11	h10	12	73	16	2	1	240011100	26,527
12	e8	12	73	16	2	1	240011200	24,705
13	h10	12	73	16	2	1	240011300	28,576
14	e8	12	73	16	2	1	240011400	28,007
15	h10	12	79	19	2	1	240011500	33,762
16	e8	16	79	19	2	1	240011600	34,269
18	e8	16	79	19	2	1	240011800	41,100
20	e8	20	88	22	2	1	240012000	49,069

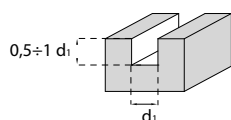

Operazione consigliata /  
Working tips

Fresa per cave  
Slot end mills

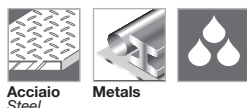

Acciai e metalli con  $R < 850 \text{ N/mm}^2$ , ghisa con durezza  $HB30 < 200$ . Steel and metals with  $R < 850 \text{ N/mm}^2$ , cast iron with  $HB30 < 200$  / Métaux et acier avec  $R < 850 \text{ N/mm}^2$ , fonte  $HB30 < 200$  / Metales e acero con  $R < 850 \text{ N/mm}^2$ , fundición  $HB30 < 200$ .

# 24003

## Frese frontali cilindriche a 2 taglienti in HSS-CO8% con attacco Weldon

HSS-CO8% two flutes end mills, Weldon shank / Fraises à rainurer HSS-CO8%, deux dents, queue Weldon

Fresas frontales HSS-CO8%, mango Weldon / Zweischneider Langlochfräser

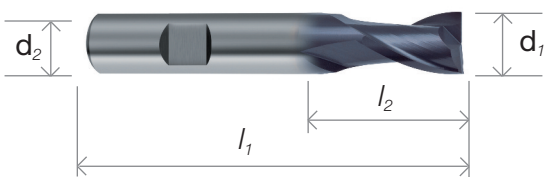
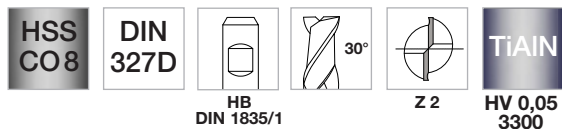

$d_1$	tol.	$d_2$	$l_1$	$l_2$	z	pcs	cod.	€ cad/each
2	e8	6	48	4	2	1	240030200	20,835
2,5	e8	6	49	5	2	1	240030250	22,998
3	e8	6	49	5	2	1	240030300	20,948
3,5	h10	6	51	7	2	1	240030350	21,632
4	e8	6	51	7	2	1	240030400	20,100
4,5	h10	6	52	8	2	1	240030450	22,035
5	e8	6	52	8	2	1	240030500	19,986
5,5	h10	6	52	8	2	1	240030550	21,290
6	e8	6	52	8	2	1	240030600	19,924
6,5	h10	10	60	10	2	1	240030650	28,463
7	e8	10	60	10	2	1	240030700	28,297
7,5	h10	10	61	11	2	1	240030750	29,891
8	e8	10	61	11	2	1	240030800	27,158
8,5	h10	10	61	11	2	1	240030850	29,322
9	h10	10	61	11	2	1	240030900	27,842
9,5	h10	10	63	13	2	1	240030950	29,715
10	e8	10	63	13	2	1	240031000	27,500
11	h10	12	73	16	2	1	240031100	35,635
12	e8	12	73	16	2	1	240031200	33,586
13	h10	12	73	16	2	1	240031300	38,709
14	e8	12	73	16	2	1	240031400	36,546
15	h10	12	79	19	2	1	240031500	42,984
16	e8	16	79	19	2	1	240031600	49,815
18	e8	16	79	19	2	1	240031800	56,646
20	e8	20	88	22	2	1	240032000	68,652

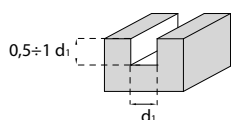

Operazione consigliata /  
Working tips

Fresa per cave  
Slot end mills

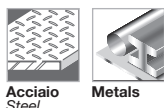

Acciai e metalli con  $R < 850 \text{ N/mm}^2$ , ghisa con durezza  $HB30 < 200$ . Steel and metals with  $R < 850 \text{ N/mm}^2$ , cast iron with  $HB30 < 200$  / Métaux et acier avec  $R < 850 \text{ N/mm}^2$ , fonte  $HB30 < 200$  / Metales e acero con  $R < 850 \text{ N/mm}^2$ , fundición  $HB30 < 200$ .

## 24002

### Frese frontali cilindriche a 2 taglienti in HSS-CO8% con attacco Weldon, serie lunga

HSS-CO8% two flutes end mills, Weldon shank / Fraises à rainurer HSS-CO8%, deux dents, queue Weldon

Fresas frontales HSS-CO8%, mango Weldon / Zweischneider Langlochfräser

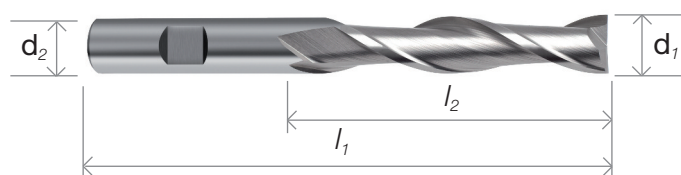
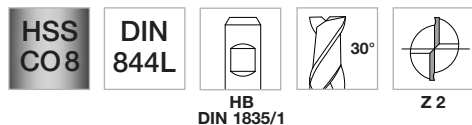

$d_1$ h10	$d_2$	$l_1$	$l_2$	Z	pcs 	cod.	€ cad/each
3	6	56	12	2	1	240020300	20,948
4	6	63	19	2	1	240020400	20,948
5	6	68	24	2	1	240020500	20,948
6	6	68	24	2	1	240020600	20,948
8	10	88	38	2	1	240020800	29,487
10	10	95	45	2	1	240021000	29,487
12	12	110	53	2	1	240021200	39,164
14	12	110	53	2	1	240021400	44,805
16	16	123	63	2	1	240021600	54,762
18	16	123	63	2	1	240021800	67,741
20	20	141	75	2	1	240022000	80,896

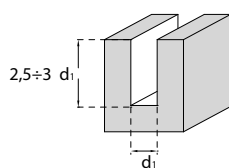

Operazione consigliata /  
Working tips

Fresa per cave  
Slot end mills

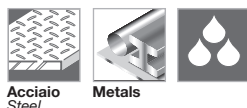

Acciai e metalli con  $R < 850 \text{ N/mm}^2$ , ghisa con durezza  $HB30 < 200$ . Steel and metals with  $R < 850 \text{ N/mm}^2$ , cast iron with  $HB30 < 200$  / Métaux et acier avec  $R < 850 \text{ N/mm}^2$ , fonte  $HB30 < 200$  / Metales e acero con  $R < 850 \text{ N/mm}^2$ , fundición  $HB30 < 200$ .

# 24004

## Frese frontali cilindriche a 2 taglienti in HSS-CO8% con attacco Weldon, serie lunga

HSS-CO8% two flutes end mills, Weldon shank / Fraises à rainurer HSS-CO8%, deux dents, queue Weldon

Fresas frontales HSS-CO8%, mango Weldon / Zweischneider Langlochfräser

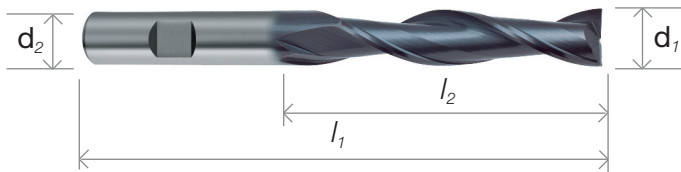
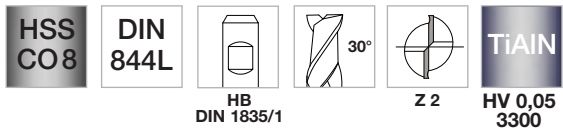

$d_1$ h10	$d_2$	$l_1$	$l_2$	Z	pcs 	cod.	€ cad/each
3	6	56	12	2	1	240040300	29,146
4	6	63	19	2	1	240040400	29,829
5	6	68	24	2	1	240040500	29,829
6	6	68	24	2	1	240040600	28,525
8	10	88	38	2	1	240040800	38,709
10	10	95	45	2	1	240041000	38,202
12	12	110	53	2	1	240041200	51,233
14	12	110	53	2	1	240041400	57,722
16	16	123	63	2	1	240041600	76,507
18	16	123	63	2	1	240041800	91,535
20	20	141	75	2	1	240042000	105,994

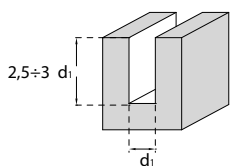

Operazione consigliata /  
Working tips

Fresa per cave  
Slot end mills

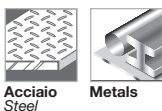

Acciai e metalli con  $R < 850 \text{ N/mm}^2$ , ghisa con durezza  $HB30 < 200$ . Steel and metals with  $R < 850 \text{ N/mm}^2$ , cast iron with  $HB30 < 200$  / Métaux et acier avec  $R < 850 \text{ N/mm}^2$ , fonte  $HB30 < 200$  / Metales e acero con  $R < 850 \text{ N/mm}^2$ , fundición  $HB30 < 200$ .

## 24005

### Frese frontali cilindriche a raggio in HSS-CO8% con attacco Weldon

HSS-CO8% round edges end mills, Weldon shank / Fraises à rainurer à bout hémisphérique HSS-CO8%, queue Weldon

Fresas frontales HSS-CO8%, mango Weldon / Zweischneder Langlochfräser

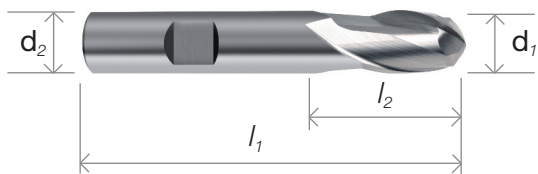
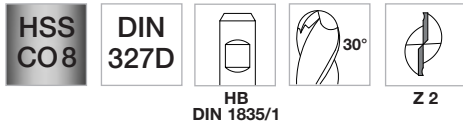

$d_1$ e8/h10	$d_2$	$l_1$	$l_2$	Z	pcs 	cod.	€ cad/each
2	6	48	4	2	1	240050200	25,275
3	6	49	5	2	1	240050300	24,933
4	6	51	7	2	1	240050400	25,275
5	6	52	8	2	1	240050500	24,705
6	6	52	8	2	1	240050600	25,275
7	10	60	10	2	1	240050700	33,079
8	10	61	11	2	1	240050800	31,712
9	10	61	11	2	1	240050900	31,712
10	10	63	13	2	1	240051000	30,915
12	12	73	16	2	1	240051200	40,137
14	12	73	16	2	1	240051400	43,377
16	16	79	19	2	1	240051600	49,866
18	16	79	19	2	1	240051800	61,427
20	20	88	22	2	1	240052000	70,018

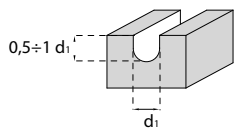

Operazione consigliata /  
Working tips

Fresa per cave  
Slot end mills

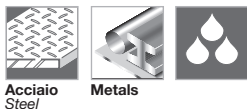

Acciai e metalli con  $R < 850$  N/mm<sup>2</sup>, ghisa con durezza HB30<200. Steel and metals with  $R < 850$  N/mm<sup>2</sup>, cast iron with HB30<200 / Métaux et acier avec  $R < 850$  N/mm<sup>2</sup>, fonte HB30<200 / Metales e acero con  $R < 850$  N/mm<sup>2</sup>, fundición HB30<200.

# 24007

## Frese frontali cilindriche a raggio in HSS-CO8% con attacco Weldon

HSS-CO8% round edges end mills, Weldon shank / Fraises à rainurer à bout hémisphérique HSS-CO8%, queue Weldon

Fresas frontales HSS-CO8%, mango Weldon / Zweischneider Langlochfräser

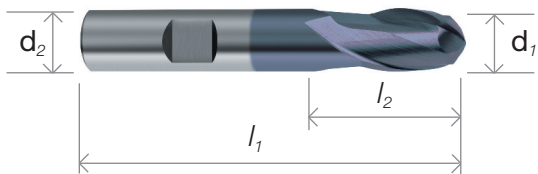

$d_1$ e8/h10	$d_2$	$l_1$	$l_2$	Z	pcs 	cod.	€ cad/each
2	6	48	4	2	1	240070200	32,789
3	6	49	5	2	1	240070300	32,623
4	6	51	7	2	1	240070400	32,220
5	6	52	8	2	1	240070500	31,599
6	6	52	8	2	1	240070600	33,306
7	10	60	10	2	1	240070700	41,617
8	10	61	11	2	1	240070800	40,251
9	10	61	11	2	1	240070900	40,251
10	10	63	13	2	1	240071000	39,392
12	12	73	16	2	1	240071200	51,688
14	12	73	16	2	1	240071400	54,596
16	16	79	19	2	1	240071600	66,716
18	16	79	19	2	1	240071800	74,634
20	20	88	22	2	1	240072000	90,169

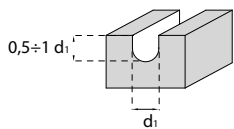

Operazione consigliata /  
Working tips

Fresa per cave  
Slot end mills

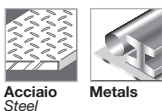

Acciai e metalli con  $R < 850 \text{ N/mm}^2$ , ghisa con durezza  $HB30 < 200$ . Steel and metals with  $R < 850 \text{ N/mm}^2$ , cast iron with  $HB30 < 200$  / Métaux et acier avec  $R < 850 \text{ N/mm}^2$ , fonte  $HB30 < 200$  / Metales e acero con  $R < 850 \text{ N/mm}^2$ , fundición  $HB30 < 200$ .

## 24006

### Frese frontali cilindriche a raggio in HSS-CO8% con attacco Weldon, serie lunga

HSS-CO8% round edges end mills, Weldon shank / Fraises à rainurer à bout hémisphérique HSS-CO8%, queue Weldon

Fresas frontales HSS-CO8%, mango Weldon / Zweischneider Langlochfräser

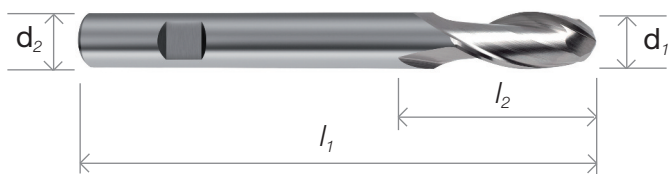

$d_1$ h10	$d_2$	$l_1$	$l_2$	Z	pcs 	cod.	€ cad/each
3	6	56	8	2	1	240060300	30,915
4	6	63	11	2	1	240060400	30,346
5	6	68	13	2	1	240060500	32,282
6	6	68	13	2	1	240060600	30,915
8	10	88	19	2	1	240060800	39,392
10	10	95	22	2	1	240061000	39,454
12	12	110	26	2	1	240061200	51,346
14	12	110	26	2	1	240061400	55,166
16	16	123	32	2	1	240061600	64,325
18	16	123	32	2	1	240061800	79,353
20	20	141	38	2	1	240062000	91,308

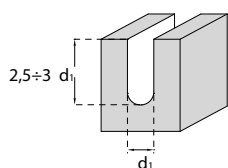

Operazione consigliata /  
Working tips

Fresa per cave  
Slot end mills

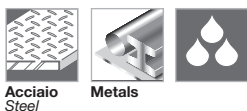

Acciai e metalli con  $R < 850 \text{ N/mm}^2$ , ghisa con durezza  $HB30 < 200$ . Steel and metals with  $R < 850 \text{ N/mm}^2$ , cast iron with  $HB30 < 200$  / Métaux et acier avec  $R < 850 \text{ N/mm}^2$ , fonte  $HB30 < 200$  / Metales e acero con  $R < 850 \text{ N/mm}^2$ , fundición  $HB30 < 200$ .

# 24008

## Frese frontali cilindriche a raggio in HSS-CO8% con attacco Weldon, serie lunga

HSS-CO8% round edges end mills, Weldon shank / Fraises à rainurer à bout hémisphérique HSS-CO8%, queue Weldon

Fresas frontales HSS-CO8%, mango Weldon / Zweischnieder Langlochfräser

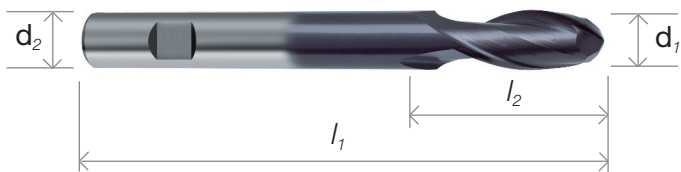

$d_1$ h10	$d_2$	$l_1$	$l_2$	Z	pcs 	cod.	€ cad/each
3	6	56	8	2	1	240080300	38,709
4	6	63	11	2	1	240080400	37,912
5	6	68	13	2	1	240080500	39,392
6	6	68	13	2	1	240080600	37,912
8	10	88	19	2	1	240080800	47,931
10	10	95	22	2	1	240081000	47,993
12	12	110	26	2	1	240081200	63,135
14	12	110	26	2	1	240081400	67,917
16	16	123	32	2	1	240081600	84,994
18	16	123	32	2	1	240081800	100,188
20	20	141	38	2	1	240082000	118,011

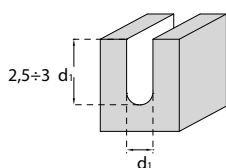

Operazione consigliata /  
Working tips

Fresa per cave  
Slot end mills

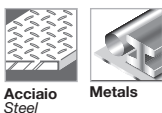

Acciai e metalli con  $R < 850 \text{ N/mm}^2$ , ghisa con durezza  $HB30 < 200$ . Steel and metals with  $R < 850 \text{ N/mm}^2$ , cast iron with  $HB30 < 200$  / Métaux et acier avec  $R < 850 \text{ N/mm}^2$ , fonte  $HB30 < 200$  / Metales e acero con  $R < 850 \text{ N/mm}^2$ , fundición  $HB30 < 200$ .



## 24025

### Frese frontali cilindriche a 4 taglienti in HSS-CO5% con attacco conico Morse

HSS-CO5% Morse taper end mills / Fraises à rainurer HSS-CO5%, queue Morse

Fresas frontales HSS-CO5%, mango Morse / Vierschneider Langlochfräser

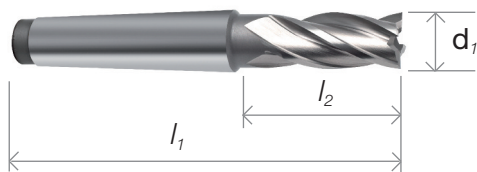

$d_1$ k10	MK	FORM	$l_1$	$l_2$	Z	pcs 	cod.	€ cad/each
16	2	B	117	32	4	1	240251600	64,046
18	2	B	117	32	4	1	240251800	67,379
20	2	B	123	38	4	1	240252000	79,478
25	3	B	147	45	6	1	240252500	113,167
28	3	B	147	45	6	1	240252800	130,048
30	3	B	147	45	6	1	240253000	140,118
32	4	B	178	53	6	1	240253200	175,836
40	4	B	178	63	6	1	240254000	272,919

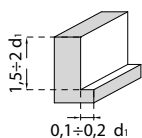

Operazione consigliata / Working tips

Fresa univesale per operazioni di finitura  
Universal end mill for finishing purpose

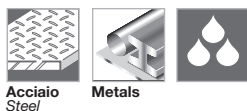

Acciai e metalli con  $R < 850 \text{ N/mm}^2$ , ghisa con durezza  $HB30 < 200$ . Steel and metals with  $R < 850 \text{ N/mm}^2$ , cast iron with  $HB30 < 200$  / Métaux et acier avec  $R < 850 \text{ N/mm}^2$ , fonte  $HB30 < 200$  / Metales e acero con  $R < 850 \text{ N/mm}^2$ , fundición  $HB30 < 200$ .

# 24026

## Frese frontali cilindriche a 4 taglienti in HSS-CO5% con attacco conico Morse, serie lunga

HSS-CO5% Morse taper end mills / Fraises à rainurer HSS-CO5%, queue Morse

Fresas frontales HSS-CO5%, mango Morse / Vierschneider Langlochfräser

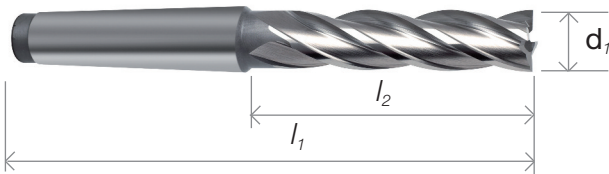

$d_1$ k10	MK	FORM	$l_1$	$l_2$	Z	pcs 	cod.	€ cad/each
16	2	B	148	63	4	1	240261600	78,826
20	2	B	160	75	4	1	240262000	108,458
25	3	B	192	90	6	1	240262500	168,446
28	3	B	192	90	6	1	240262800	192,717
32	4	B	231	106	6	1	240263200	270,166
40	4	B	250	125	6	1	240264000	434,628

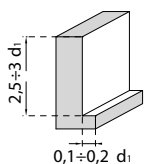

Operazione consigliata / Working tips

Fresa univesale per operazioni di finitura  
Universal end mill for finishing purpose

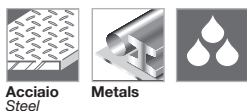

Acciai e metalli con  $R < 850 \text{ N/mm}^2$ , ghisa con durezza  $HB30 < 200$ . Steel and metals with  $R < 850 \text{ N/mm}^2$ , cast iron with  $HB30 < 200$  / Métaux et acier avec  $R < 850 \text{ N/mm}^2$ , fonte  $HB30 < 200$  / Metales e acero con  $R < 850 \text{ N/mm}^2$ , fundición  $HB30 < 200$ .

## 24029

**Frese frontali cilindriche a 4 taglienti a sgrossare in HSS-CO5% con attacco conico Morse**

HSS-CO5% Morse taper end mills for roughing purpose / Fraises à rainurer HSS-CO5%, queue Morse, pour dégrossissage

Fresas frontales HSS-CO5%, mango Morse / Vierschneider Langlochfräser

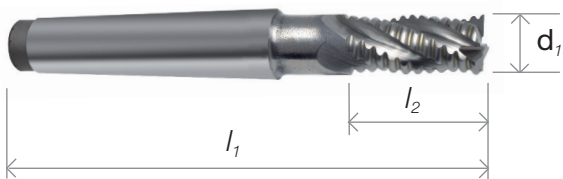
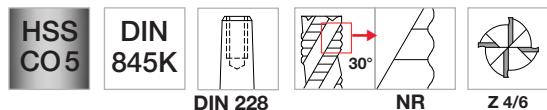

$d_1$ k12	MK	FORM	$l_1$	$l_2$	Z	pcs 	cod.	€ cad/each
16	2	B	117	32	4	1	240291600	90,273
18	2	B	117	32	4	1	240291800	93,678
20	2	B	123	38	4	1	240292000	111,211
25	3	B	147	45	6	1	240292500	152,942
28	3	B	147	45	6	1	240292800	173,156
30	3	B	147	45	6	1	240293000	186,631

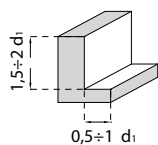

Operazione consigliata / Working tips

Fresa univesale per operazioni di sgrossatura  
Universal end mill for roughing purpose

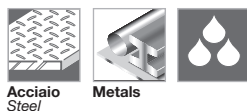

Acciai e metalli con  $R < 850 \text{ N/mm}^2$ , ghisa con durezza  $HB30 < 200$ . Steel and metals with  $R < 850 \text{ N/mm}^2$ , cast iron with  $HB30 < 200$  / Métaux et acier avec  $R < 850 \text{ N/mm}^2$ , fonte  $HB30 < 200$  / Metales e acero con  $R < 850 \text{ N/mm}^2$ , fundición  $HB30 < 200$ .

# 24030

## Frese frontali a 4 taglienti a sgrossare in HSS-CO5% con attacco conico Morse, serie lunga

HSS-CO5% Morse taper end mills / Fraises à rainurer HSS-CO5%, queue Morse

Fresas frontales HSS-CO5%, mango Morse / Vierschneider Langlochfräser

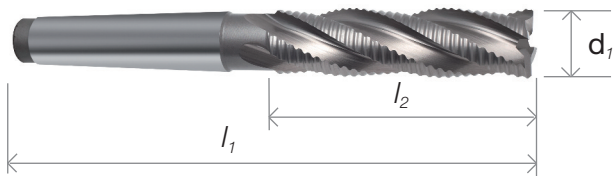
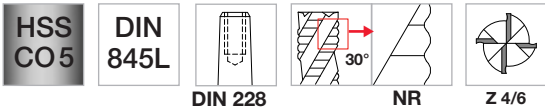

$d_1$ k12	MK	FORM	$l_1$	$l_2$	Z	pcs 	cod.	€ cad/each
16	2	B	148	63	4	1	240301600	121,281
20	2	B	160	75	4	1	240302000	154,319
25	3	B	192	90	6	1	240302500	219,668
28	3	B	192	90	6	1	240302800	251,981

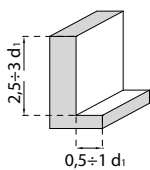

Operazione consigliata / Working tips

Fresa univesale per operazioni di sgrossatura  
Universal end mill for roughing purpose

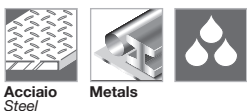

Acciai e metalli con  $R < 850$  N/mm<sup>2</sup>, ghisa con durezza HB30 < 200. Steel and metals with  $R < 850$  N/mm<sup>2</sup>, cast iron with HB30 < 200 / Métaux et acier avec  $R < 850$  N/mm<sup>2</sup>, fonte HB30 < 200 / Metales e acero con  $R < 850$  N/mm<sup>2</sup>, fundición HB30 < 200.

## 24165

### Frese frontali a 4 taglienti in metallo duro integrale

Four flutes carbide end mills / Fraise carbure quatre dents

Fresas frontales de metal duro cuatro dientes / Hartmetall Vierschneider Langlochfräser

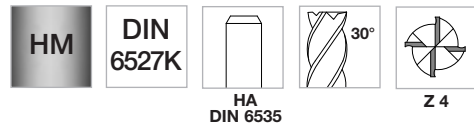

## METALLO DURO/CARBIDE

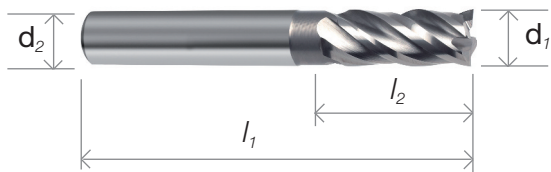

$d_1$ h10	$d_2$	$l_1$	$l_2$	Z	pcs 	cod.	€ cad/each
2	6	50	4	4	1	241650200	29,187
3	6	50	5	4	1	241650300	26,341
4	6	54	8	4	1	241650400	24,633
5	6	54	9	4	1	241650500	24,633
6	6	54	10	4	1	241650600	29,912
8	8	58	12	4	1	241650800	42,694
10	10	66	14	4	1	241651000	62,618
12	12	73	16	4	1	241651200	81,144
14	14	75	18	4	1	241651400	108,158
16	16	82	22	4	1	241651600	139,466
18	18	84	24	4	1	241651800	206,379
20	20	92	26	4	1	241652000	219,161

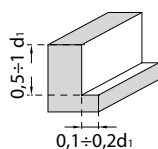

Operazione consigliata / Working tips

Fresa univesale per operazioni di finitura  
Universal end mill for finishing purpose



Acciai e metalli duri, acciai per lavorazioni a caldo, acciai legati con  $R < 1200 \text{ N/mm}^2$ , acciai dolci, bronzo, ghisa, leghe Al-Si. Structural and case hardened steels, cast steels, heat treatable steels, alloyed steels up to  $R < 1200 \text{ N/mm}^2$ , carbon steels, bronze, cast iron, Al-Si alloys. / Aciers et métaux durs, aciers pour les usinages à chaud, aciers alliés avec  $R < 1200 \text{ N/mm}^2$ , aciers doux, bronze, fonte, alliages Al-Si. / Aceros y metales duros, aceros para trabajos en caliente, aceros aleados con  $R < 1200 \text{ N/mm}^2$ , aceros dulces, bronze, hierro fundido y aleaciones Al-Si.

# 24167

## Frese frontali a 4 taglienti in metallo duro integrale

Four flutes carbide end mills / Fraise carbure quatre dents

Fresas frontales de metal duro cuatro dientes / Hartmetall Vierschneider Langlochfräser



### METALLO DURO/CARBIDE

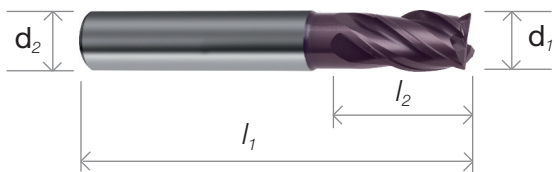

$d_1$ h10	$d_2$	$l_1$	$l_2$	Z	pcs 	cod.	€ cad/each
2	6	50	4	4	1	241670200	35,035
3	6	50	5	4	1	241670300	31,619
4	6	54	8	4	1	241670400	29,549
5	6	54	9	4	1	241670500	29,549
6	6	54	10	4	1	241670600	35,863
8	8	58	12	4	1	241670800	51,233
10	10	66	14	4	1	241671000	75,141
12	12	73	16	4	1	241671200	97,342
14	14	75	18	4	1	241671400	129,789
16	16	82	22	4	1	241671600	167,360
18	18	84	24	4	1	241671800	247,624
20	20	92	26	4	1	241672000	262,994

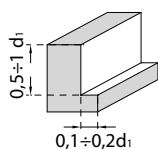

Operazione consigliata / Working tips

Fresa univesale per operazioni di finitura  
Universal end mill for finishing purpose

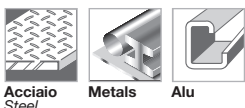

Acciai e metalli duri, acciai per lavorazioni a caldo, acciai legati con  $R < 1200 \text{ N/mm}^2$ , acciai dolci, bronzo, ghisa, leghe Al-Si. Structural and case hardened steels, cast steels, heat treatable steels, alloyed steels up to  $R < 1200 \text{ N/mm}^2$ , carbon steels, bronze, cast iron, Al-Si alloys. / Aciers et métaux durs, aciers pour les usinages à chaud, aciers alliés avec  $R < 1200 \text{ N/mm}^2$ , aciers doux, bronze, fonte, alliages Al-Si. / Aceros y metales duros, aceros para trabajos en caliente, aceros aleados con  $R < 1200 \text{ N/mm}^2$ , aceros dulces, bronze, hierro fundido y aleaciones Al-Si.

## 24166

### Frese frontali a 4 taglienti in metallo duro integrale, serie lunga

Four flutes carbide end mills / Fraise carbure quatre dents

Fresas frontales de metal duro cuatro dientes / Hartmetall Vierschneider Langlochfräser

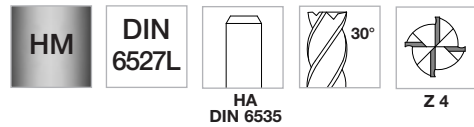

## METALLO DURO/CARBIDE

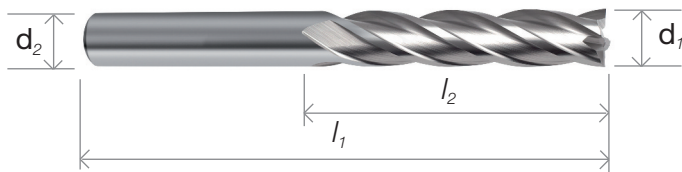

$d_1$ h10	$d_2$	$l_1$	$l_2$	Z	pcs 	cod.	€ cad/each
2	6	57	7	4	1	241660200	39,796
3	6	57	8	4	1	241660300	32,447
4	6	57	11	4	1	241660400	31,412
5	6	57	13	4	1	241660500	30,947
6	6	57	13	4	1	241660600	30,222
8	8	63	19	4	1	241660800	40,469
9	10	72	19	4	1	241660900	71,312
10	10	72	22	4	1	241661000	58,892
12	12	83	26	4	1	241661200	84,404
14	14	83	26	4	1	241661400	116,489
16	16	92	32	4	1	241661600	138,276
18	18	92	32	4	1	241661800	205,189
20	20	104	38	4	1	241662000	215,798

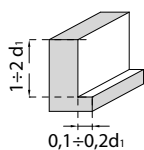

Operazione consigliata / Working tips

Fresa univesale per operazioni di finitura  
Universal end mill for finishing purpose



Acciai e metalli duri, acciai per lavorazioni a caldo, acciai legati con  $R < 1200 \text{ N/mm}^2$ , acciai dolci, bronzo, ghisa, leghe Al-Si. Structural and case hardened steels, cast steels, heat treatable steels, alloyed steels up to  $R < 1200 \text{ N/mm}^2$ , carbon steels, bronze, cast iron, Al-Si alloys. / Aciers et métaux durs, aciers pour les usinages à chaud, aciers alliés avec  $R < 1200 \text{ N/mm}^2$ , aciers doux, bronze, fonte, alliages Al-Si. / Aceros y metales duros, aceros para trabajos en caliente, aceros aleados con  $R < 1200 \text{ N/mm}^2$ , aceros dulces, bronce, hierro fundido y aleaciones Al-Si.

# 24168

## Frese frontali a 4 taglienti in metallo duro integrale, serie lunga

Four flutes carbide end mills / Fraise carbure quatre dents

Fresas frontales de metal duro cuatro dientes / Hartmetall Vierschneider Langlochfräser



### METALLO DURO/CARBIDE

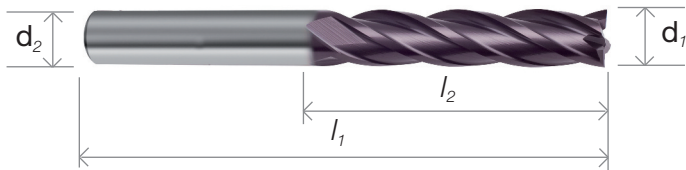

$d_1$ h10	$d_2$	$l_1$	$l_2$	Z	pcs 	cod.	€ cad/each
2	6	57	7	4	1	241680200	47,765
3	6	57	8	4	1	241680300	38,916
4	6	57	11	4	1	241680400	38,916
5	6	57	13	4	1	241680500	37,157
6	6	57	13	4	1	241680600	37,157
8	8	63	19	4	1	241680800	48,542
9	10	72	19	4	1	241680900	85,595
10	10	72	22	4	1	241681000	70,691
12	12	83	26	4	1	241681200	101,275
14	14	83	26	4	1	241681400	139,829
16	16	92	32	4	1	241681600	165,911
18	18	92	32	4	1	241681800	246,227
20	20	104	38	4	1	241682000	258,957

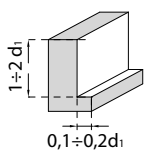

Operazione consigliata / Working tips

Fresa univesale per operazioni di finitura  
Universal end mill for finishing purpose

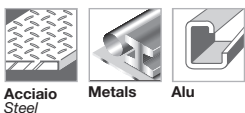

Acciai e metalli duri, acciai per lavorazioni a caldo, acciai legati con  $R < 1200 \text{ N/mm}^2$ , acciai dolci, bronzo, ghisa, leghe Al-Si. Structural and case hardened steels, cast steels, heat treatable steels, alloyed steels up to  $R < 1200 \text{ N/mm}^2$ , carbon steels, bronze, cast iron, Al-Si alloys. / Aciers et métaux durs, aciers pour les usinages à chaud, aciers alliés avec  $R < 1200 \text{ N/mm}^2$ , aciers doux, bronze, fonte, alliages Al-Si. / Aceros y metales duros, aceros para trabajos en caliente, aceros aleados con  $R < 1200 \text{ N/mm}^2$ , aceros dulces, bronce, hierro fundido y aleaciones Al-Si.



## 24169

### Frese frontali a 4 taglienti ad elica variabile in metallo duro integrale, serie lunga

Four flutes carbide end mills with variable helix / Fraise carbure quatre dents avec helice variable

Fresas frontales de metal duro cuatro dientes con helica variable / Hartmetall Vierschneider Langlochfräser

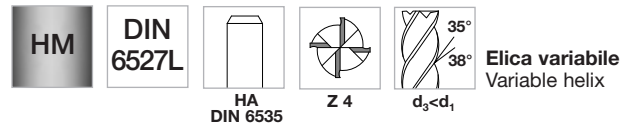

**METALLO DURO/CARBIDE**  
**LEGHE DI TITANIO / TITANIUM ALLOYS**

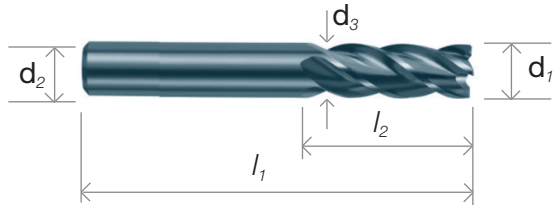

d <sub>1</sub> h10	d <sub>2</sub>	d <sub>3</sub>	l <sub>1</sub>	l <sub>2</sub>	Z	pcs 	cod.	€ cad/each
4	6	3,7	57	11	4	1	241690400	38,036
5	6	4,7	57	13	4	1	241690500	38,036
6	6	5,5	57	13	4	1	241690600	37,260
8	8	7,5	63	19	4	1	241690800	43,470
10	10	9,2	72	22	4	1	241691000	72,968
12	12	11,2	83	26	4	1	241691200	104,018
14	14	13,2	83	26	4	1	241691400	141,278
16	16	15,0	92	32	4	1	241691600	172,328
18	18	17,0	92	32	4	1	241691800	248,400
20	20	19,0	104	38	4	1	241692000	287,213

#### Operazione consigliata / Working tips

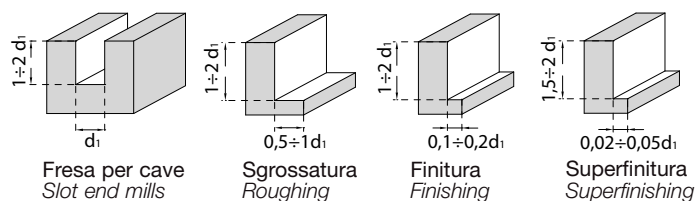

Questi utensili ad elica variabile (35°-38°) sono adatti alle lavorazioni di titanio e sue leghe, oltre che dei comuni metalli, con ottimi rendimenti e minime vibrazioni. Il titanio, metallo strutturale usato in ambito aeronautico e medico per l'ottimo rapporto resistenza/peso (20:1), è di difficile lavorabilità perché produce trucioli spezzettati, che generano sollecitazioni variabili sull'utensile e, perché ha una bassa conducibilità termica, che causa elevate sollecitazioni termiche sui taglienti. Ha inoltre un basso modulo elastico e tende pertanto a deformarsi plasticamente. Si consiglia durante le lavorazioni l'utilizzo di una coppia elevata ed un basso numero di giri. These tools with variable helix angle (35°-38°) are suitable for cutting titanium, its alloys, and common metals as well, assuring great performances and low vibrations. Titanium is a structural metal: it's used in aerospace and medical field thanks to the optimum compromise between strength and weight (20:1). It's hardly workable because it makes chopped chips which increase the tool vibrations and it has a very low thermal conductivity that causes high thermal stress on the cutting edges. It has a low Young's modulus and it easily distorts. You'd better use high torque and low speed (rpm) when working titanium and its alloys. / Ces outils à hélice variable (35° - 38°) conviennent aux usinages du titane et de ses alliages, ainsi que des métaux communs, avec d'excellents rendements et peu de vibrations. Le titane, métal pour les structures, utilisé dans l'aéronautique et le secteur médical pour son excellent rapport résistance/poids (20:1), est difficile à usiner car il produit des copeaux hachés qui génèrent des sollicitations variables sur l'outil. Il possède également une faible conductivité thermique, ce qui entraîne des contraintes thermiques élevées sur les bords de coupe. Il possède également un module d'élasticité bas et tend donc à se déformer plastiquement. Il est recommandé d'utiliser un couple élevé et un faible nombre de tours pendant l'usinage. / Estos utensilios con hélice variable (35°-38°) son ideales para trabajar sobre titanio y sus aleaciones, además de sobre los metales comunes, con óptimos rendimientos y mínimas vibraciones. El titanio, metal estructural empleado en el campo aeronáutico y médico por la ideal relación entre resistencia y peso (20:1), es difícil de trabajar porque produce virutas troceadas, que generan estreses variables en el utensilio y porque tiene una capacidad de conducción térmica baja, que causa elevados estreses térmicos en el borde de corte. También tiene un bajo módulo elástico y por tanto tiende a deformarse plásticamente. Durante su elaboración se aconseja utilizar un par de torsión elevado y un bajo número de revoluciones.

# 24171

## Frese frontali a 4 taglianti ad elica variabile in metallo duro integrale, serie lunga

Four flutes carbide end mills with variable helix / Fraise carbure quatre dents avec helice variable

Fresas frontales de metal duro cuatro dientes con helica variable / Hartmetall Vierschneider Langlochfräser

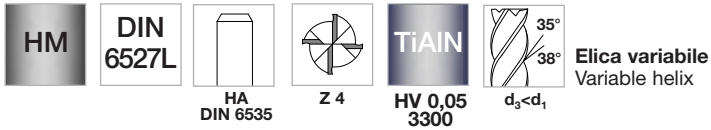

**METALLO DURO/CARBIDE**  
LEGHE DI TITANIO / TITANIUM ALLOYS

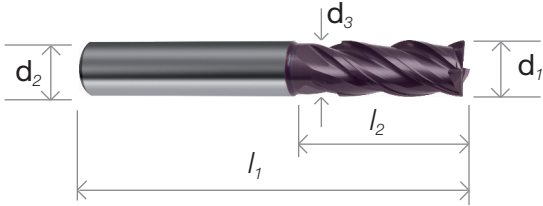

$d_1$ h10	$d_2$	$d_3$	$l_1$	$l_2$	Z	pcs 	cod.	€ cad/each
4	6	3,7	57	11	4	1	241710400	53,561
5	6	4,7	57	13	4	1	241710500	53,561
6	6	5,5	57	13	4	1	241710600	65,205
8	8	7,5	63	19	4	1	241710800	90,045
10	10	9,2	72	22	4	1	241711000	136,620
12	12	11,2	83	26	4	1	241711200	173,880
14	14	13,2	83	26	4	1	241711400	234,428
16	16	15,0	92	32	4	1	241711600	301,185
18	18	17,0	92	32	4	1	241711800	416,070
20	20	19,0	104	38	4	1	241712000	468,855

### Operazione consigliata / Working tips

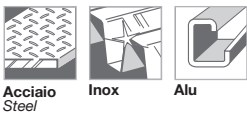
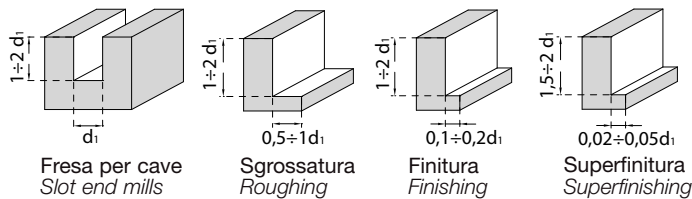

## 24170

Frese frontali a 4 taglienti ad elica variabile in metallo duro integrale, serie extra lunga

Four flutes carbide end mills with variable helix / Fraise carbure quatre dents avec helice variable

Fresas frontales de metal duro cuatro dientes con helica variable / Hartmetall Vierschneider Langlochfräser

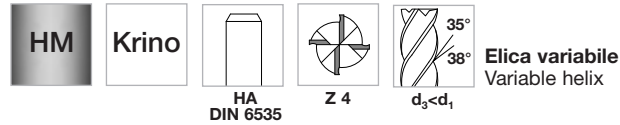

**METALLO DURO/CARBIDE**  
LEGHE DI TITANIO / TITANIUM ALLOYS

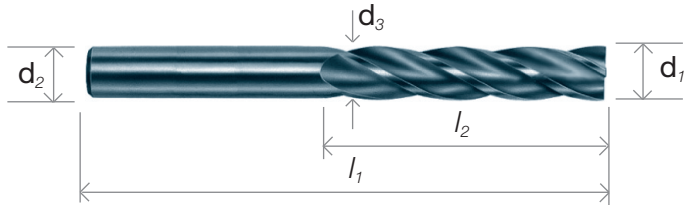

$d_1$ h10	$d_2$	$d_3$	$l_1$	$l_2$	Z	pcs 	cod.	€ cad/each
10	10	9,2	100	40	4	1	241701000	144,900
12	12	11,2	150	45	4	1	241701200	231,840
14	14	13,2	150	45	4	1	241701400	307,188
16	16	15,0	150	65	4	1	241701600	411,516
18	18	17,0	150	65	4	1	241701800	463,680
20	20	19,0	150	65	4	1	241702000	541,926

Operazione consigliata / Working tips

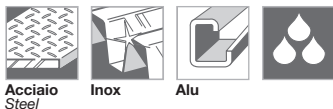
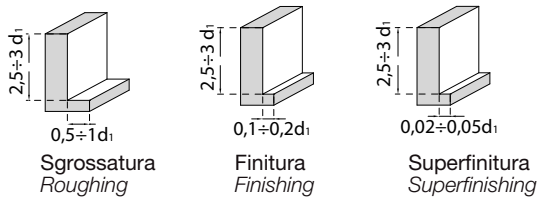

# 24172

## Frese frontali a 4 taglienti ad elica variabile in metallo duro integrale, serie extra lunga

Four flutes carbide end mills with variable helix / Fraise carbure quatre dents avec helice variable

Fresas frontales de metal duro cuatro dientes con helica variable / Hartmetall Vierschneider Langlochfräser

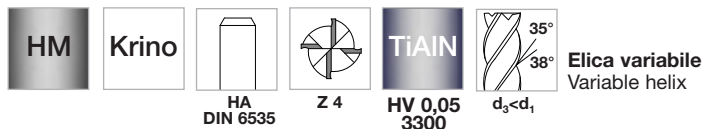

**METALLO DURO/CARBIDE**  
LEGHE DI TITANIO / TITANIUM ALLOYS

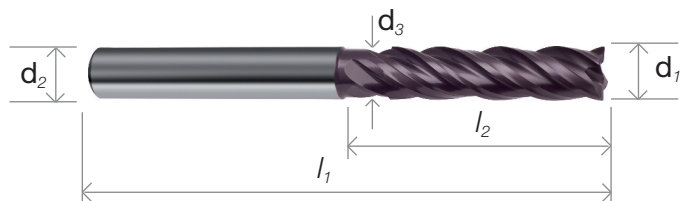

$d_1$ h10	$d_2$	$d_3$	$l_1$	$l_2$	Z	pcs 	cod.	€ cad/each
10	10	9,2	100	40	4	1	241721000	205,758
12	12	11,2	150	45	4	1	241721200	295,596
14	14	13,2	150	45	4	1	241721400	411,516
16	16	15,0	150	65	4	1	241721600	556,416
18	18	17,0	150	65	4	1	241721800	625,968
20	20	19,0	150	65	4	1	241722000	738,990

### Operazione consigliata / Working tips

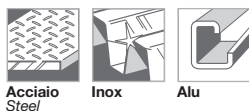
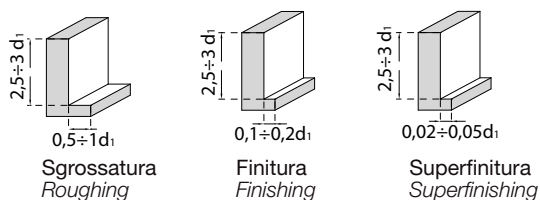

## 24174

### Frese frontali a 4 taglienti ad elica variabile in metallo duro integrale, serie lunga.

Carbide end mills with variable helix, TiAlN coated / Fraises carbure avec helice variable

Fresas frontales de metal duro con helica variable



**METALLO DURO/CARBIDE**  
SPECIALE INOX / SPECIAL STAINLESS STEEL

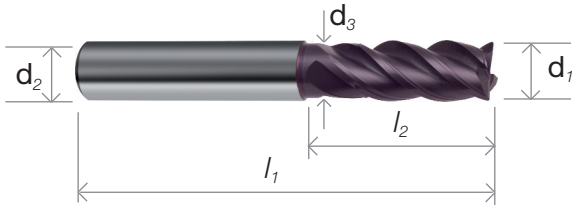

d <sub>1</sub> h10	d <sub>2</sub>	d <sub>3</sub>	l <sub>1</sub>	l <sub>2</sub>	Z	pcs	cod.	€ cad/each
4	6	3,7	57	11	4	1	241740400	62,928
5	6	4,7	57	13	4	1	241740500	62,928
6	6	5,5	57	13	4	1	241740600	77,004
8	8	7,5	63	19	4	1	241740800	107,640
10	10	9,2	72	22	4	1	241741000	160,632
12	12	11,2	83	26	4	1	241741200	205,344
16	16	15,0	92	32	4	1	241741600	354,384
20	20	19,0	104	38	4	1	241742000	546,480

#### Operazione consigliata / Working tips

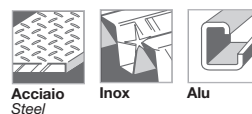
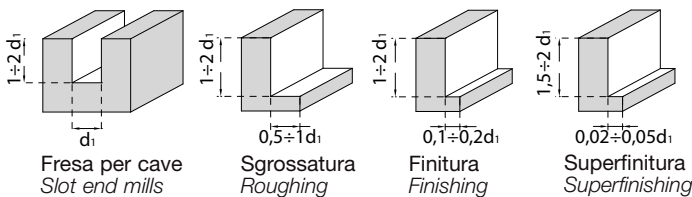

Questi utensili ad elica variabile (40°-42°) sono adatti alle lavorazioni dell'acciaio inossidabile, oltre che dei comuni metalli, con ottimi rendimenti e minime vibrazioni. L'acciaio inox martensitico è il più diffuso, perché presenta le migliori caratteristiche meccaniche (rispetto al ferritico e all'austenitico): ha una buona lavorabilità e trova impiego in applicazioni marine, impianti di desalinizzazione, scambiatori di calore, impianti petrolchimici e impieghi strutturali. L'inox austenitico, maggiormente resistente alla corrosione, trova principalmente impiego nell'industria chimica, farmaceutica, alimentare. Richiede grandi potenze per essere lavorato, perché ha forte tendenza all'incrudimento: si raccomandano pertanto basse velocità di taglio e avanzamenti elevati. L'inox ferritico, non temprabile, ha scarsa lavorabilità e impieghi principali in campo elettronico, impiantistico, serbatoi e cisterne d'acqua. These tools with variable helix angle (40°-42°) are suitable for cutting stainless steel and common metals, assuring great performances and low vibrations. Martensitic stainless steel is widespread, because it has the best mechanical properties. It's easy workable and it's use in marine field, heat exchanger, petrochemical plants, structurals. Austenitic stainless steel, that's the most corrosion resistant, is used in chemical, pharmaceutical, food and beverage industries. It needs high power to be cut because it works harden. It's better to use low rpm and high feed. Ferritic stainless steel, that's not hardenable, is hardly workable: its main use is in electronic and plant fields, water and fluid tanks. / Ces outils à hélice variable (40° - 42°) conviennent aux usinages de l'acier inoxydable, ainsi que des métaux communs, avec d'excellents rendements et peu de vibrations. L'acier inoxydable martensitique est le plus répandu, parce qu'il présente les meilleures propriétés mécaniques (par rapport au ferritique et à l'austénitique): il se travaille bien et est utilisé dans des applications marines, dans les usines de dessalement, les échangeurs de chaleur, les usines pétrochimiques ainsi que dans des applications structurales. L'acier inoxydable austénitique, plus résistant à la corrosion, est principalement utilisé dans l'industrie chimique, pharmaceutique, alimentaire. Il nécessite de grandes puissances pour être travaillé car il possède une forte tendance au durcissement : nous recommandons donc de faibles vitesses de coupe et des avancements élevés. L'acier inoxydable ferritique, qui ne peut pas être trempé, ne se travaille pas facilement et est principalement utilisé dans le domaine électronique, les installations, les réservoirs et les citernes d'eau. / Estos utensilios con hélice variable (40°-42°) son ideales para trabajar el acero inoxidable, además de los metales comunes, con óptimos rendimientos y mínimas vibraciones. El acero inoxidable martensítico es el más difundido porque presenta las mejores características mecánicas (con respecto al ferrítico y al austenítico): es fácil de trabajar y se puede emplear en aplicaciones marinas, sistemas de desalinización, intercambiadores de calor, plantas petrolquímicas y empleos estructurales. El acero inoxidable austenítico, muy resistente a la corrosión, se utiliza principalmente en la industria química, farmacéutica y alimenticia. Requiere grandes potencias para ser trabajado, porque tiende al endurecimiento: por lo tanto se aconsejan bajas velocidades de corte y elevados

# 24175

Frese frontali a 4 taglienti ad elica variabile in metallo duro integrale, serie lunga con attacco Weldon

Carbide end mills with variable helix, TiAlN coated / Fraises carbure avec helice variable

Fresas frontales de metal duro con helica variable

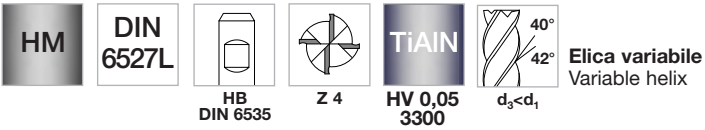

**METALLO DURO/CARBIDE**  
SPECIALE INOX / SPECIAL STAINLESS STEEL

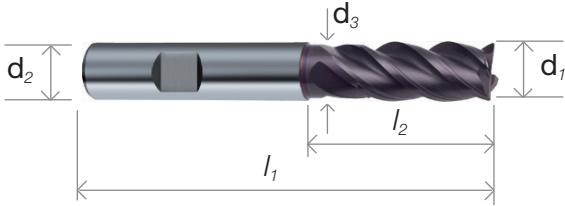

$d_1$ h10	$d_2$	$d_3$	$l_1$	$l_2$	Z	pcs 	cod.	€ cad/each
4	6	3,7	57	11	4	1	241750400	62,928
5	6	4,7	57	13	4	1	241750500	62,928
6	6	5,5	57	13	4	1	241750600	77,004
8	8	7,5	63	19	4	1	241750800	107,640
10	10	9,2	72	22	4	1	241751000	160,632
12	12	11,2	83	26	4	1	241751200	205,344
16	16	15,0	92	32	4	1	241751600	354,384
20	20	19,0	104	38	4	1	241752000	546,480

Operazione consigliata / Working tips

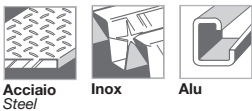
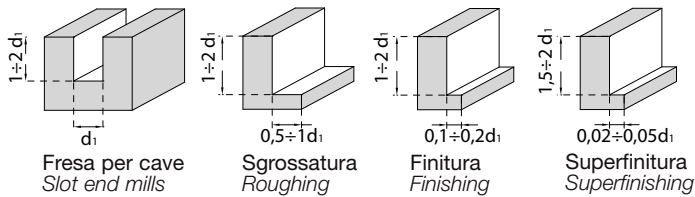

## 24183

Frese frontali a 4 taglienti in metallo duro integrale, serie lunga con attacco Weldon

Four and three flutes carbide end mills TiAlN coated / Fraise carbure quatre et trois dents TiAlN

Fresas frontales de metal duro cuatro y tres dientes, TiAlN



**METALLO DURO/CARBIDE**

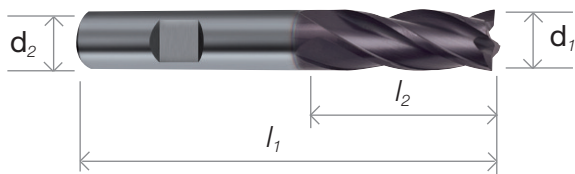

$d_1$ h10	$d_2$	$l_1$	$l_2$	Z	pcs 	cod.	€ cad/each
2	6	57	7	4	1	241830200	50,612
3	6	57	8	4	1	241830300	41,762
4	6	57	11	4	1	241830400	40,520
5	6	57	13	4	1	241830500	40,520
6	6	57	13	4	1	241830600	40,520
8	8	63	19	4	1	241830800	51,388
9	9	72	19	4	1	241830900	88,441
10	10	72	22	4	1	241831000	73,537
12	12	83	26	4	1	241831200	105,415
14	14	83	26	4	1	241831400	143,969
16	16	92	32	4	1	241831600	170,051
18	18	92	32	4	1	241831800	252,437
20	20	104	38	4	1	241832000	265,167

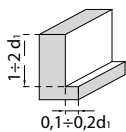

Operazione consigliata / Working tips

Fresa univesale per operazioni di finitura  
Universal end mill for finishing purpose



Acciai e metalli duri, acciai per lavorazioni a caldo, acciai legati con  $R < 1200 \text{ N/mm}^2$ , acciai dolci, bronzo, ghisa, leghe Al-Si. Structural and case hardened steels, cast steels, heat treatable steels, alloyed steels up to  $R < 1200 \text{ N/mm}^2$ , carbon steels, bronze, cast iron, Al-Si alloys. / Aciers et métaux durs, aciers pour les usinages à chaud, aciers alliés avec  $R < 1200 \text{ N/mm}^2$ , aciers doux, bronze, fonte, alliages Al-Si. / Aceros y metales duros, aceros para trabajos en caliente, aceros aleados con  $R < 1200 \text{ N/mm}^2$ , aceros dulces, bronce, hierro fundido y aleaciones Al-Si.

# 24182

## Frese frontali a sgrossare a 4 taglienti in metallo duro integrale, serie lunga con attacco Weldon

Four flutes carbide end mills / Fraise carbure quatre dents

Fresas frontales de metal duro cuatro dientes / Hartmetall Vierschneider Langlochfräser

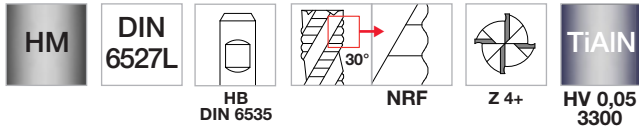

### METALLO DURO/CARBIDE

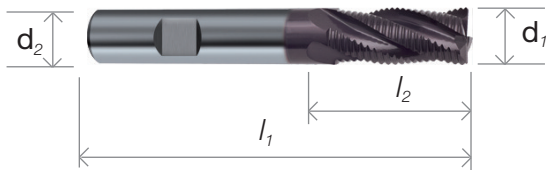

$d_1$ h10	$d_2$	$l_1$	$l_2$	Z	pcs 	cod.	€ cad/each
6	6	57	13	4	1	241820600	110,797
8	8	63	19	4	1	241820800	126,736
10	10	72	22	4	1	241821000	138,742
12	12	83	26	4	1	241821200	164,565
14	14	83	26	4	1	241821400	230,029
16	16	92	32	4	1	241821600	338,342
18	18	92	32	4	1	241821800	261,907
20	20	104	38	4	1	241822000	390,350
25	25	121	45	5	1	241822500	693,191

#### Operazione consigliata / Working tips

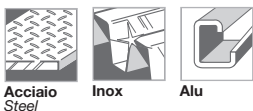
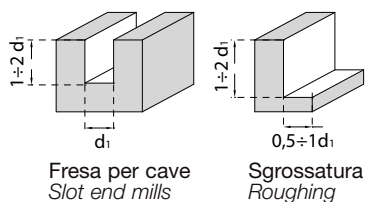

La speciale geometria dell'utensile (rompitrucciolo di tipo NRF) consente lavorazioni con finitura superficiale  $R_a = 2\div3 \mu\text{m}$ . Questo rende superfluo un ulteriore passaggio di finitura. The special tool geometrical features (NRF chipbreaker) let you create a superficial finishing  $R_a = 2\div3 \mu\text{m}$  thus avoiding any further finishing operation. / La forme particulière de l'outil (broyeur de copeaux de type NRF) permet l'usinage avec une finition de surface  $R_a = 2\div3 \mu\text{m}$ . Cela élimine une étape supplémentaire de finition. / La especial geometría del utensilio (rompe-virutas de tipo NRF) consente trabajos con acabado superficial  $R_a = 2\div3 \mu\text{m}$ . Esto hace que un ulterior remate en el acabado resulte superfluo.



## 24181

### Frese frontali a 3 taglienti in metallo duro integrale, con attacco Weldon

Three flutes carbide end mills / Fraise carbure trois dents

Fresas frontales de metal duro tres dientes / Hartmetall Dreischneider Langlochfräser

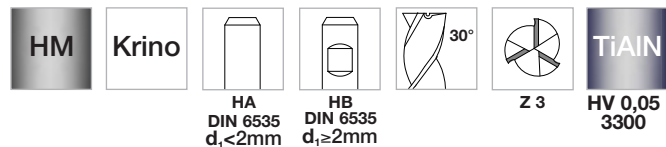

## METALLO DURO/CARBIDE

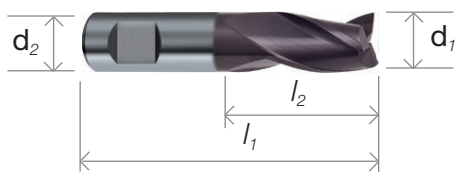

$d_1$ e8	$d_2$	$l_1$	$l_2$	Z	pcs 	cod.	€ cad/each
0,5	3	38	1,5	3	1	241810050	26,030
1	3	38	2	3	1	241810100	27,842
1,5	3	38	2	3	1	241810150	27,842
2	6	38	4	3	1	241810200	28,825
2,5	6	38	5	3	1	241810250	30,791
3	6	38	5	3	1	241810300	28,825
3,5	6	38	6	3	1	241810350	30,791
4	6	38	7	3	1	241810400	29,705
4,5	6	38	8	3	1	241810450	33,845
5	6	38	8	3	1	241810500	32,603
6	6	38	8	3	1	241810600	32,603
8	8	43	11	3	1	241810800	45,074
10	10	50	13	3	1	241811000	65,102
12	12	55	15	3	1	241811200	78,557

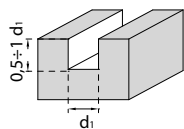

Operazione consigliata /  
Working tips

Fresa per cave  
Slot end mills



Acciai e metalli duri, acciai per lavorazioni a caldo, acciai legati con  $R < 1200 \text{ N/mm}^2$ , acciai dolci, bronzo, ghisa, leghe Al-Si. Structural and case hardened steels, cast steels, heat treatable steels, alloyed steels up to  $R < 1200 \text{ N/mm}^2$ , carbon steels, bronze, cast iron, Al-Si alloys. / Aciers et métaux durs, aciers pour les usinages à chaud, aciers alliés avec  $R < 1200 \text{ N/mm}^2$ , aciers doux, bronze, fonte, alliages Al-Si. / Aceros y metales duros, aceros para trabajos en caliente, aceros aleados con  $R < 1200 \text{ N/mm}^2$ , aceros dulces, bronce, hierro fundido y aleaciones Al-Si.

# 24184

## Frese frontali a 3 taglienti in metallo duro integrale, serie lunga con attacco Weldon

Four and three flutes carbide end mills TiAIN coated / Fraise carbure quatre et trois dents TiAIN

Fresas frontales de metal duro cuatro y tres dientes, TiAIN

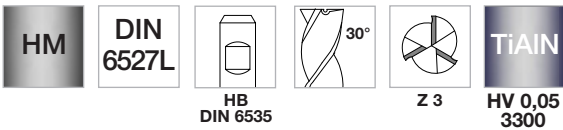

### METALLO DURO/CARBIDE

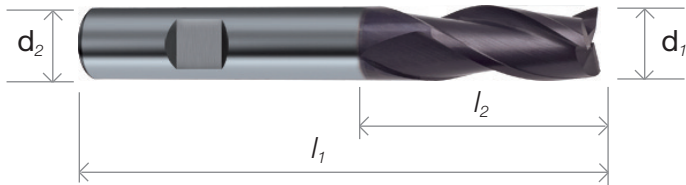

$d_1$ h10	$d_2$	$l_1$	$l_2$	Z	pcs 	cod.	€ cad/each
2	6	57	6	3	1	241840200	51,905
3	6	57	7	3	1	241840300	51,905
4	6	57	8	3	1	241840400	49,680
5	6	57	10	3	1	241840500	49,680
6	6	57	10	3	1	241840600	49,680
8	8	63	16	3	1	241840800	64,222
9	10	72	16	3	1	241840900	86,888
10	10	72	19	3	1	241841000	92,063
12	12	83	22	3	1	241841200	131,238
14	14	83	22	3	1	241841400	169,274
16	16	92	26	3	1	241841600	211,554
18	18	92	26	3	1	241841800	290,939
20	20	104	32	3	1	241842000	331,976

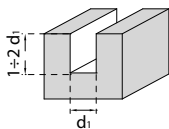

Operazione consigliata /  
Working tips

Fresa per cave  
Slot end mills



Acciai e metalli duri, acciai per lavorazioni a caldo, acciai legati con  $R < 1200 \text{ N/mm}^2$ , acciai dolci, bronzo, ghisa, leghe Al-Si. Structural and case hardened steels, cast steels, heat treatable steels, alloyed steels up to  $R < 1200 \text{ N/mm}^2$ , carbon steels, bronze, cast iron, Al-Si alloys. / Aciers et métaux durs, aciers pour les usinages à chaud, aciers alliés avec  $R < 1200 \text{ N/mm}^2$ , aciers doux, bronze, fonte, alliages Al-Si. / Aceros y metales duros, aceros para trabajos en caliente, aceros aleados con  $R < 1200 \text{ N/mm}^2$ , aceros dulces, bronce, hierro fundido y aleaciones Al-Si.

## 24161

### Frese frontali a 3 taglienti in metallo duro integrale, serie lunga

Three flutes carbide end mills / Fraise carbure trois dents

Fresas frontales de metal duro tres dientes / Hartmetall Dreischneider Langlochfräser

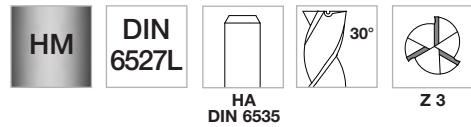

## METALLO DURO/CARBIDE

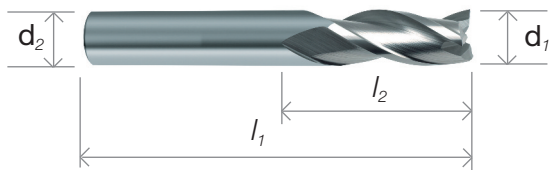

$d_1$ h10	$d_2$	$l_1$	$l_2$	Z	pcs 	cod.	€ cad/each
3	6	57	7	3	1	241610300	40,883
4	6	57	8	3	1	241610400	39,020
5	6	57	10	3	1	241610500	39,020
6	6	57	10	3	1	241610600	39,020
8	8	63	16	3	1	241610800	51,129
9	10	72	16	3	1	241610900	70,018
10	10	72	19	3	1	241611000	74,313
12	12	83	22	3	1	241611200	105,932
14	14	83	22	3	1	241611400	137,603
16	16	92	26	3	1	241611600	172,845
18	18	92	26	3	1	241611800	237,274
20	20	104	32	3	1	241612000	271,481

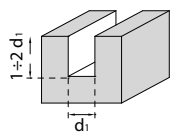

Operazione consigliata /  
Working tips

Fresa per cave  
Slot end mills



Acciai e metalli duri, acciai per lavorazioni a caldo, acciai legati con  $R < 1200 \text{ N/mm}^2$ , acciai dolci, bronzo, ghisa, leghe Al-Si. Structural and case hardened steels, cast steels, heat treatable steels, alloyed steels up to  $R < 1200 \text{ N/mm}^2$ , carbon steels, bronze, cast iron, Al-Si alloys. / Aciers et métaux durs, aciers pour les usinages à chaud, aciers alliés avec  $R < 1200 \text{ N/mm}^2$ , aciers doux, bronze, fonte, alliages Al-Si. / Aceros y metales duros, aceros para trabajos en caliente, aceros aleados con  $R < 1200 \text{ N/mm}^2$ , aceros dulces, bronce, hierro fundido y aleaciones Al-Si.

# 24163

## Frese frontali a 3 taglienti in metallo duro integrale, serie lunga

Three flutes carbide end mills / Fraise carbure trois dents

Fresas frontales de metal duro tres dientes / Hartmetall Dreischneider Langlochfräser

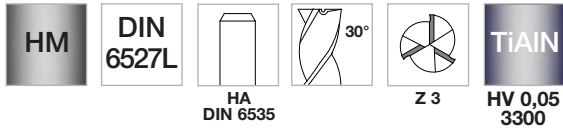

### METALLO DURO/CARBIDE

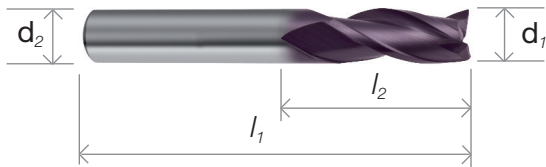

$d_1$ h10	$d_2$	$l_1$	$l_2$	Z	pcs 	cod.	€ cad/each
3	6	57	7	3	1	241630300	49,059
4	6	57	8	3	1	241630400	46,834
5	6	57	10	3	1	241630500	46,834
6	6	57	10	3	1	241630600	46,834
8	8	63	16	3	1	241630800	61,376
9	10	72	16	3	1	241630900	84,042
10	10	72	19	3	1	241631000	89,217
12	12	83	22	3	1	241631200	127,098
14	14	83	22	3	1	241631400	165,134
16	16	92	26	3	1	241631600	207,414
18	18	92	26	3	1	241631800	284,729
20	20	104	32	3	1	241632000	325,766

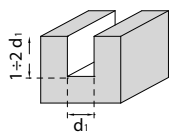

Operazione consigliata /  
Working tips

Fresa per cave  
Slot end mills

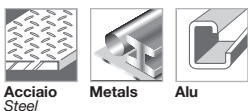

Acciai e metalli duri, acciai per lavorazioni a caldo, acciai legati con  $R < 1200 \text{ N/mm}^2$ , acciai dolci, bronzo, ghisa, leghe Al-Si. Structural and case hardened steels, cast steels, heat treatable steels, alloyed steels up to  $R < 1200 \text{ N/mm}^2$ , carbon steels, bronze, cast iron, Al-Si alloys. / Aciers et métaux durs, aciers pour les usinages à chaud, aciers alliés avec  $R < 1200 \text{ N/mm}^2$ , aciers doux, bronze, fonte, alliages Al-Si. / Aceros y metales duros, aceros para trabajos en caliente, aceros aleados con  $R < 1200 \text{ N/mm}^2$ , aceros dulces, bronce, hierro fundido y aleaciones Al-Si.

## 24162

### Frese frontali a 3 taglienti in metallo duro integrale, serie extra lunga

Three flutes carbide end mills / Fraise carbure trois dents

Fresas frontales de metal duro tres dientes / Hartmetall Dreischneider Langlochfräser

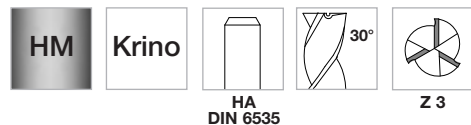

## METALLO DURO/CARBIDE

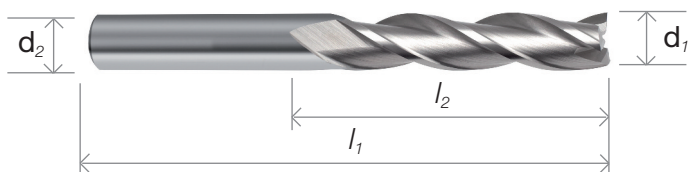

$d_1$ h10	$d_2$	$l_1$	$l_2$	Z	pcs 	cod.	€ cad/each
3	3	75	20	3	1	241620300	48,128
4	4	75	25	3	1	241620400	52,785
5	5	75	30	3	1	241620500	58,219
6	6	75	30	3	1	241620600	76,073
8	8	100	40	3	1	241620800	97,808
10	10	100	40	3	1	241621000	128,858
12	12	150	45	3	1	241621200	184,748
16	16	150	65	3	1	241621600	344,655
20	20	150	65	3	1	241622000	453,330

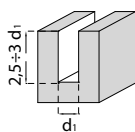

Operazione consigliata /  
Working tips

Fresa per cave  
Slot end mills

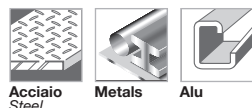

Acciai e metalli duri, acciai per lavorazioni a caldo, acciai legati con  $R < 1200 \text{ N/mm}^2$ , acciai dolci, bronzo, ghisa, leghe Al-Si. Structural and case hardened steels, cast steels, heat treatable steels, alloyed steels up to  $R < 1200 \text{ N/mm}^2$ , carbon steels, bronze, cast iron, Al-Si alloys. / Aciers et métaux durs, aciers pour les usinages à chaud, aciers alliés avec  $R < 1200 \text{ N/mm}^2$ , aciers doux, bronze, fonte, alliages Al-Si. / Aceros y metales duros, aceros para trabajos en caliente, aceros aleados con  $R < 1200 \text{ N/mm}^2$ , aceros dulces, bronce, hierro fundido y aleaciones Al-Si.

# 24164

## Frese frontali a 3 taglienti in metallo duro integrale, serie extra lunga

Three flutes carbide end mills / Fraise carbure trois dents

Fresas frontales de metal duro tres dientes / Hartmetall Dreischneider Langlochfräser

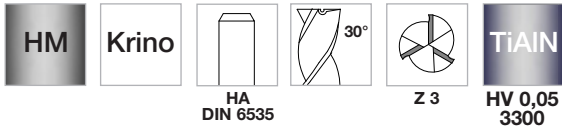

### METALLO DURO/CARBIDE

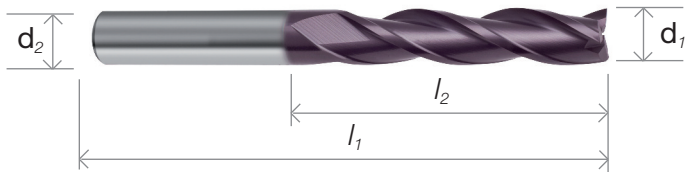

$d_1$ h10	$d_2$	$l_1$	$l_2$	Z	pcs 	cod.	€ cad/each
3	3	75	20	3	1	241640300	57,753
4	4	75	25	3	1	241640400	63,342
5	5	75	30	3	1	241640500	69,863
6	6	75	30	3	1	241640600	91,287
8	8	100	40	3	1	241640800	117,369
10	10	100	40	3	1	241641000	154,629
12	12	150	45	3	1	241641200	221,697
16	16	150	65	3	1	241641600	413,586
20	20	150	65	3	1	241642000	543,996

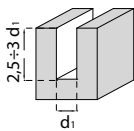

Operazione consigliata /  
Working tips

Fresa per cave  
Slot end mills

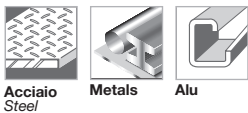

Acciai e metalli duri, acciai per lavorazioni a caldo, acciai legati con  $R < 1200 \text{ N/mm}^2$ , acciai dolci, bronzo, ghisa, leghe Al-Si. Structural and case hardened steels, cast steels, heat treatable steels, alloyed steels up to  $R < 1200 \text{ N/mm}^2$ , carbon steels, bronze, cast iron, Al-Si alloys. / Aciers et métaux durs, aciers pour les usinages à chaud, aciers alliés avec  $R < 1200 \text{ N/mm}^2$ , aciers doux, bronze, fonte, alliages Al-Si. / Aceros y metales duros, aceros para trabajos en caliente, aceros aleados con  $R < 1200 \text{ N/mm}^2$ , aceros dulces, bronce, hierro fundido y aleaciones Al-Si.

## 24156

### Frese frontali a 3 taglienti con canalina di refrigerazione in metallo duro integrale, serie lunga

Carbide end mills for aluminium / Fraise carbure pour aluminium / Fresas frontales de metal duro para aluminium / Hartmetall Langlochfräser für Aluminium

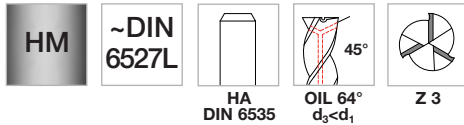

**METALLO DURO/CARBIDE**  
**SPECIALE ALLUMINIO / ALUMINIUM CUT**

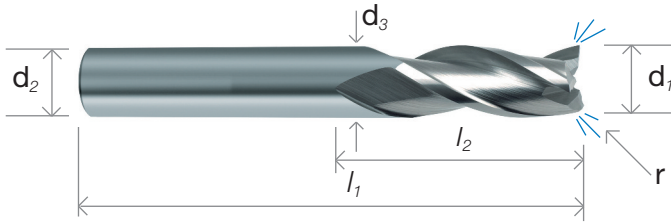

$d_1$ h10	$d_2$	$d_3$	$l_1$	$l_2$	$r$	$Z$	pcs 	cod.	€ cad/each
6	6	5,7	57	10	1	3	1	241560600	82,800
8	8	7,7	63	16	1	3	1	241560800	93,150
10	10	9,5	72	19	1,5	3	1	241561000	165,600
12	12	11,5	83	22	1,5	3	1	241561200	240,120
16	16	15,5	92	26	2	3	1	241561600	382,950
20	20	19,5	104	32	2,5	3	1	241562000	542,340

#### Operazione consigliata / Working tips

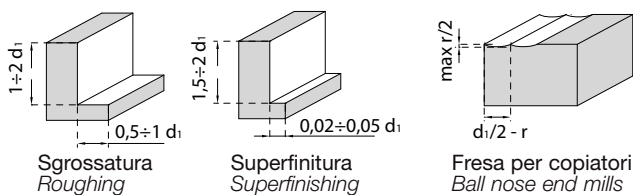

L'alluminio è molto utilizzato nell'industria automobilistica, aeronautica e aerospaziale perché è leggero e resistente alla corrosione. E' facile da lavorare e ha una buona conducibilità termica. Durante le lavorazioni per asportazione di truciolo, il tagliente di riporto può essere evitato utilizzando velocità di taglio elevate. Il silicio, uno dei principali elementi delle leghe di alluminio, è una particella fragile e resistente che, da un lato, favorisce la spezzettatura del truciolo, ma dall'altro aumenta l'usura abrasiva dell'utensile. Aluminium is mainly used in automotive, aerospace and aeronautic industries, because it's light and corrosion resistant. It's easily workable and it has good thermal conductivity. Using high cutting speed, the built-up edge is easily avoidable. Silicon is one of the most common used element in aluminium alloys: it's fragile and resisting, thus both making chopped chips and increasing the abrasive wear on the cutting edges. / L'aluminium est largement utilisé dans l'industrie automobile, aéronautique et aérospatiale, car il est léger et résistant à la corrosion. Il est facile à travailler et possède une bonne conductivité thermique. Lors de l'usinage par enlèvement des copeaux, le bord d'accumulation peut être évité en utilisant des vitesses de coupe élevées. Le silicium, l'un des principaux éléments des alliages d'aluminium, est une particule fragile et résistante qui, d'une part, favorise le découpage en morceaux du copeau mais d'autre part augmente l'usure par abrasion de l'outil. / El aluminio se emplea mucho en la industria automovilística, aeronáutica y aeroespacial porque es ligero y resistente a la corrosión. Es fácil de trabajar y tiene buena capacidad de conducción térmica. Durante los trabajos de eliminación de virutas, el borde de corte de aporte se puede evitar utilizando velocidades de corte elevadas. El silicio, uno de los principales elementos en las aleaciones de aluminio, es una partícula frágil y resistente que por un lado, ayuda a desmenuzar las virutas, pero por otra parte aumenta el desgaste abrasivo del utensilio.

# 24180

## Frese frontali a 3 taglienti ad elica variabile in metallo duro integrale, serie lunga

Carbide end mills with variable helix, TiAlN coated / Fraises carbure avec helice variable

Fresas frontales de metal duro con helica variable

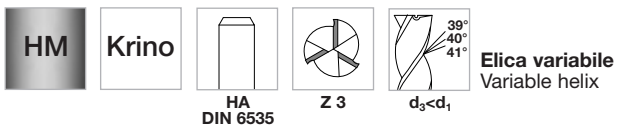

**METALLO DURO/CARBIDE**  
SPECIALE ALLUMINIO / ALUMINIUM CUT

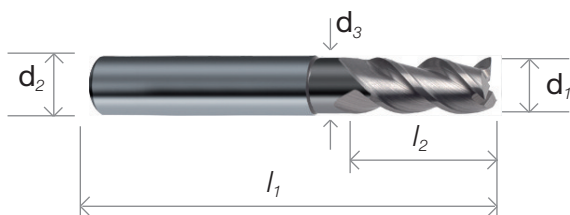

$d_1$ h10	$d_2$	$d_3$	$l_1$	$l_2$	Z	pcs 	cod.	€ cad/each
3	6	2,7	57	8	3	1	241800300	50,405
4	6	3,7	57	11	3	1	241800400	54,182
5	6	4,7	57	13	3	1	241800500	54,441
6	6	5,5	57	13	3	1	241800600	50,922
8	8	7,5	63	16	3	1	241800800	68,724
10	10	9,2	72	19	3	1	241801000	93,875
12	12	11,2	83	22	3	1	241801200	130,979
16	16	15,0	92	26	3	1	241801600	219,161
20	20	19,0	104	32	3	1	241802000	348,329

### Operazione consigliata / Working tips

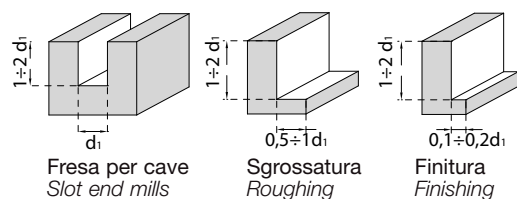



## 24154

### Frese frontali a 2 taglienti in metallo duro integrale

Carbide end mills for aluminium / Fraise carbure pour aluminium / Fresas frontales de metal duro para aluminium / Hartmetall Langlochfräser für Aluminium

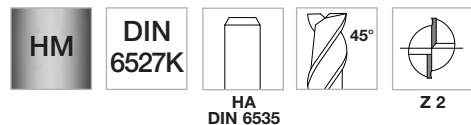

**METALLO DURO/CARBIDE**  
**SPECIALE ALLUMINIO / ALUMINIUM CUT**

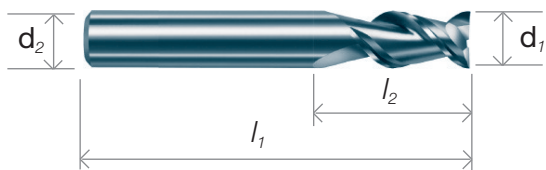

$d_1$ e8	$d_2$	$l_1$	$l_2$	Z	pcs	cod.	€ cad/each	$d_1$ e8	$d_2$	$l_1$	$l_2$	Z	pcs	cod.	€ cad/each
3	6	50	4	2	1	241540300	33,638	12	12	73	12	2	1	241541200	86,681
4	6	54	5	2	1	241540400	33,638	14	14	75	14	2	1	241541400	120,319
5	6	54	6	2	1	241540500	33,638	16	16	82	16	2	1	241541600	129,375
6	6	54	7	2	1	241540600	33,638	18	18	84	18	2	1	241541800	175,950
8	8	58	9	2	1	241540800	40,365	20	20	92	20	2	1	241542000	232,875
10	10	66	11	2	1	241541000	54,338								

#### Operazione consigliata / Working tips

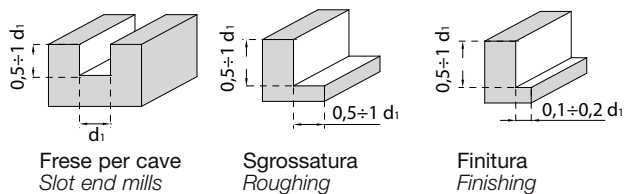

## 26100

### Fresa per pantografi ad 1 dente per taglio alluminio

One flute end mills for aluminium / Fraise avec un dent pour aluminium  
Fresa con un diente para aluminium / Einzahn fräser für Aluminium



**HSS**  
**SPECIALE ALLUMINIO / ALUMINIUM CUT**

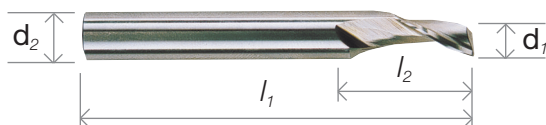

$d_1$ e8	$d_2$	$l_1$	$l_2$	Z	pcs	cod.	€ cad/each	$d_1$ e8	$d_2$	$l_1$	$l_2$	Z	pcs	cod.	€ cad/each
3	8	60	12	1	1	2610003060	24,633	6	8	60	14	1	1	2610006060	24,633
4	8	60	12	1	1	2610004060	24,633	6	8	90	16	1	1	2610006090	34,797
4	8	80	16	1	1	2610004080	34,797	8	8	80	15	1	1	2610008080	30,056
5	8	60	12	1	1	2610005060	24,633	8	8	100	28	1	1	2610008100	38,616
5	8	80	16	1	1	2610005080	34,797	10	10	80	15	1	1	2610010080	30,957



# 24155

## Frese frontali a 2 taglienti in metallo duro integrale, serie extra lunga

Carbide end mills for aluminium / Fraise carbure pour aluminium / Fresas frontales de metal duro para aluminium / Hartmetall Langlochfräser für Aluminium

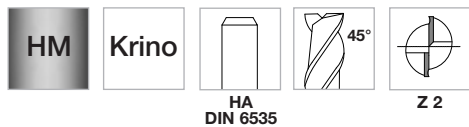

**METALLO DURO/CARBIDE**  
SPECIALE ALLUMINIO / ALUMINIUM CUT

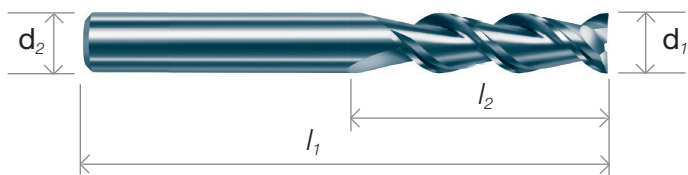

$d_1$ e8	$d_2$	$l_1$	$l_2$	Z	pcs 	cod.	€ cad/each
5	5	75	30	2	1	241550500	61,738
6	6	75	30	2	1	241550600	83,835
8	8	100	40	2	1	241550800	101,327
10	10	100	40	2	1	241551000	142,054
12	12	150	45	2	1	241551200	223,560
16	16	150	65	2	1	241551600	409,860

### Operazione consigliata / Working tips

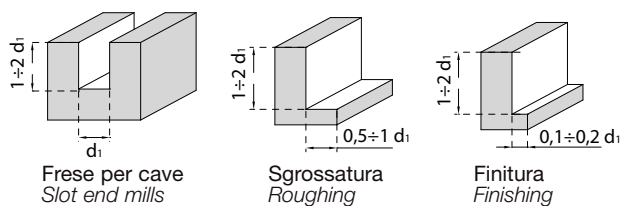

## 24150

### Frese frontali a 2 taglienti in metallo duro integrale

Two-flutes carbide end mills / Fraise carbure deux dents

Fresas frontales de metal duro dos dientes / Hartmetall Zweischneider Langlochfräser

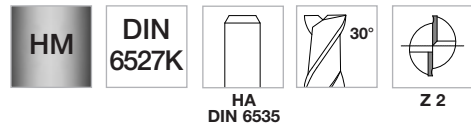

## METALLO DURO/CARBIDE

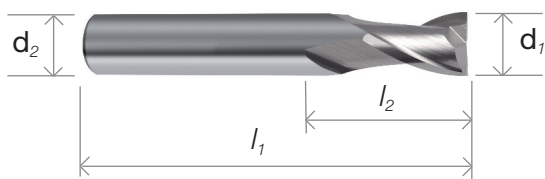

$d_1$	$d_2$	$l_1$	$l_2$	Z	pcs 	cod.	€ cad/each
2	6	50	3	2	1	241500200	32,499
3	6	50	4	2	1	241500300	31,671
4	6	54	5	2	1	241500400	30,636
5	6	54	6	2	1	241500500	30,636
6	6	54	7	2	1	241500600	29,394
8	8	58	9	2	1	241500800	40,779
10	10	66	11	2	1	241501000	60,030
12	12	73	12	2	1	241501200	87,975
14	14	75	14	2	1	241501400	122,130
16	16	82	16	2	1	241501600	140,760
18	18	84	18	2	1	241501800	215,280
20	20	92	20	2	1	241502000	229,770

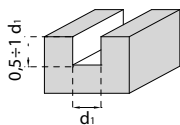

Operazione consigliata /  
Working tips

Fresa per cave  
Slot end mills



Acciai e metalli duri, acciai per lavorazioni a caldo, acciai legati con  $R < 1200 \text{ N/mm}^2$ , acciai dolci, bronzo, ghisa, leghe Al-Si. Structural and case hardened steels, cast steels, heat treatable steels, alloyed steels up to  $R < 1200 \text{ N/mm}^2$ , carbon steels, bronze, cast iron, Al-Si alloys. / Aciers et métaux durs, aciers pour les usinages à chaud, aciers alliés avec  $R < 1200 \text{ N/mm}^2$ , aciers doux, bronze, fonte, alliages Al-Si. / Aceros y metales duros, aceros para trabajos en caliente, aceros aleados con  $R < 1200 \text{ N/mm}^2$ , aceros dulces, bronce, hierro fundido y aleaciones Al-Si.

# 24152

## Frese frontali a 2 taglienti in metallo duro integrale

Two-flutes carbide end mills / Fraise carbure deux dents

Fresas frontales de metal duro dos dientes / Hartmetall Zweischneider Langlochfräser



### METALLO DURO/CARBIDE

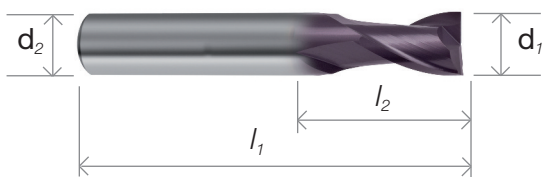

$d_1$	$d_2$	$l_1$	$l_2$	Z	pcs	cod.	€ cad/each
2	6	50	3	2	1	241520200	39,020
3	6	50	4	2	1	241520300	37,985
4	6	54	5	2	1	241520400	36,743
5	6	54	6	2	1	241520500	36,743
6	6	54	7	2	1	241520600	35,294
8	8	58	9	2	1	241520800	48,956
10	10	66	11	2	1	241521000	72,036
12	12	73	12	2	1	241521200	105,570
14	14	75	14	2	1	241521400	146,556
16	16	82	16	2	1	241521600	168,912
18	18	84	18	2	1	241521800	258,336
20	20	92	20	2	1	241522000	275,724

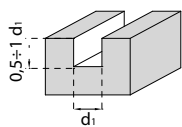

Operazione consigliata /  
Working tips

Fresa per cave  
Slot end mills



Acciaio  
Steel



Alu Si 3-12%



Ghisa  
Cast iron



Acciai e metalli duri, acciai per lavorazioni a caldo, acciai legati con  $R < 1200 \text{ N/mm}^2$ , acciai dolci, bronzo, ghisa, leghe Al-Si. Structural and case hardened steels, cast steels, heat treatable steels, alloyed steels up to  $R < 1200 \text{ N/mm}^2$ , carbon steels, bronze, cast iron, Al-Si alloys. / Aciers et métaux durs, aciers pour les usinages à chaud, aciers alliés avec  $R < 1200 \text{ N/mm}^2$ , aciers doux, bronze, fonte, alliages Al-Si. / Aceros y metales duros, aceros para trabajos en caliente, aceros aleados con  $R < 1200 \text{ N/mm}^2$ , aceros dulces, bronce, hierro fundido y aleaciones Al-Si.

## 24151

### Frese frontali a 2 taglienti in metallo duro integrale, serie extra lunga

Two-flutes carbide end mills / Fraise carbure deux dents

Fresas frontales de metal duro dos dientes / Hartmetall Zweischneider Langlochfräser

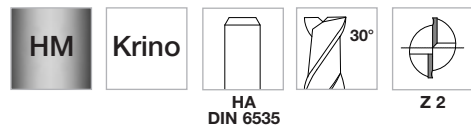

## METALLO DURO/CARBIDE

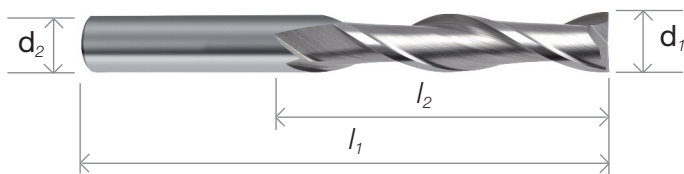

d <sub>1</sub>	d <sub>2</sub>	l <sub>1</sub>	l <sub>2</sub>	Z	pcs	cod.	€ cad/each
3	3	75	20	2	1	241510300	47,144
4	4	75	25	2	1	241510400	52,009
5	5	75	30	2	1	241510500	54,493
6	6	75	30	2	1	241510600	54,493
8	8	100	40	2	1	241510800	106,709
10	10	100	40	2	1	241511000	128,961
12	12	150	45	2	1	241511200	198,410
14	14	150	45	2	1	241511400	242,966
16	16	150	65	2	1	241511600	322,403
18	18	150	65	2	1	241511800	384,399
20	20	150	65	2	1	241512000	434,079

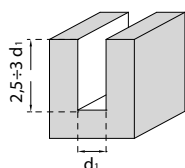

Operazione consigliata /  
Working tips

Fresa per cave  
Slot end mills



Acciai e metalli duri, acciai per lavorazioni a caldo, acciai legati con R<1200 N/mm<sup>2</sup>, acciai dolci, bronzo, ghisa, leghe Al-Si. Structural and case hardened steels, cast steels, heat treatable steels, alloyed steels up to R<1200 N/mm<sup>2</sup>, carbon steels, bronze, cast iron, Al-Si alloys. / Aciers et métaux durs, aciers pour les usinages à chaud, aciers alliés avec R<1200 N/mm<sup>2</sup>, aciers doux, bronze, fonte, alliages Al-Si. / Aceros y metales duros, aceros para trabajos en caliente, aceros aleados con R<1200 N/mm<sup>2</sup>, aceros dulces, bronce, hierro fundido y aleaciones Al-Si.

# 24153

## Frese frontali a 2 taglienti in metallo duro integrale, serie extra lunga

Two-flutes carbide end mills / Fraise carbure deux dents

Fresas frontales de metal duro dos dientes / Hartmetall Zweischneider Langlochfräser



### METALLO DURO/CARBIDE

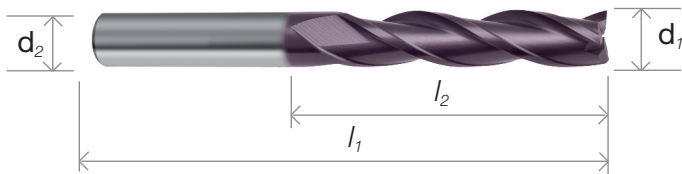

$d_1$	$d_2$	$l_1$	$l_2$	Z	pcs 	cod.	€ cad/each
3	3	75	20	2	1	241530300	56,563
4	4	75	25	2	1	241530400	62,411
5	5	75	30	2	1	241530500	65,412
6	6	75	30	2	1	241530600	65,412
8	8	100	40	2	1	241530800	128,030
10	10	100	40	2	1	241531000	154,784
12	12	150	45	2	1	241531200	238,050
14	14	150	45	2	1	241531400	291,560
16	16	150	65	2	1	241531600	386,883
18	18	150	65	2	1	241531800	461,300
20	20	150	65	2	1	241532000	520,916

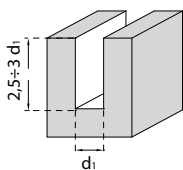

Operazione consigliata /  
Working tips

Fresa per cave  
Slot end mills

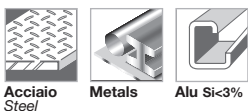

Acciai e metalli duri, acciai per lavorazioni a caldo, acciai legati con  $R < 1200 \text{ N/mm}^2$ , acciai dolci, bronzo, ghisa, leghe Al-Si. Structural and case hardened steels, cast steels, heat treatable steels, alloyed steels up to  $R < 1200 \text{ N/mm}^2$ , carbon steels, bronze, cast iron, Al-Si alloys. / Aciers et métaux durs, aciers pour les usinages à chaud, aciers alliés avec  $R < 1200 \text{ N/mm}^2$ , aciers doux, bronze, fonte, alliages Al-Si. / Aceros y metales duros, aceros para trabajos en caliente, aceros aleados con  $R < 1200 \text{ N/mm}^2$ , aceros dulces, bronce, hierro fundido y aleaciones Al-Si.

## 24157

### Frese frontali a raggio in metallo duro integrale, serie lunga

Carbide end mills with ball end / Fraise carbure à bout hémisphérique

Fresas frontales radiales de metal duro / Hartmetall Langlochfräser

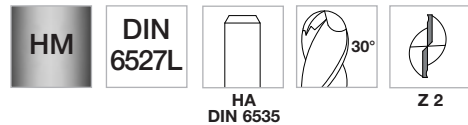

## METALLO DURO/CARBIDE

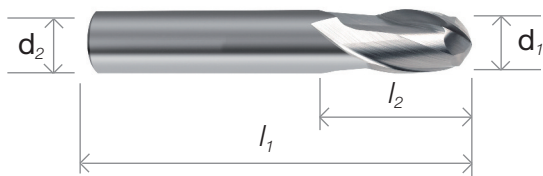

$d_1$ h10	$d_2$	$l_1$	$l_2$	Z	pcs 	cod.	€ cad/each
2	6	57	6	2	1	241570200	50,612
3	6	57	7	2	1	241570300	43,988
4	6	57	8	2	1	241570400	43,004
5	6	57	10	2	1	241570500	43,988
6	6	57	10	2	1	241570600	43,004
8	8	63	16	2	1	241570800	51,181
10	10	72	19	2	1	241571000	65,309
12	12	83	22	2	1	241571200	97,549
14	14	83	22	2	1	241571400	125,442
16	16	92	26	2	1	241571600	154,215
18	18	92	26	2	1	241571800	185,420
20	20	104	32	2	1	241572000	245,813

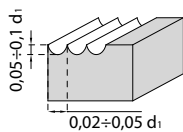

Operazione consigliata /  
Working tips

Frese per copiatori  
Ball nose end mills



Acciai e metalli duri, acciai per lavorazioni a caldo, acciai legati con  $R < 1200 \text{ N/mm}^2$ , acciai dolci, bronzo, ghisa, leghe Al-Si. Structural and case hardened steels, cast steels, heat treatable steels, alloyed steels up to  $R < 1200 \text{ N/mm}^2$ , carbon steels, bronze, cast iron, Al-Si alloys. / Aciers et métaux durs, aciers pour les usinages à chaud, aciers alliés avec  $R < 1200 \text{ N/mm}^2$ , aciers doux, bronze, fonte, alliages Al-Si. / Aceros y metales duros, aceros para trabajos en caliente, aceros aleados con  $R < 1200 \text{ N/mm}^2$ , aceros dulces, bronce, hierro fundido y aleaciones Al-Si.

# 24159

## Frese frontali a raggio in metallo duro integrale, serie lunga

Carbide end mills with ball end / Fraise carbure à bout hémisphérique

Fresas frontales radiales de metal duro / Hartmetall Langlochfräser



## METALLO DURO/CARBIDE

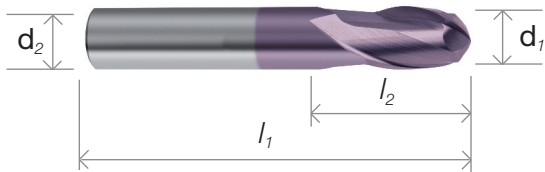

$d_1$ h10	$d_2$	$l_1$	$l_2$	Z	pcs	cod.	€ cad/each
2	6	57	6	2	1	241590200	62,514
3	6	57	7	2	1	241590300	52,837
4	6	57	8	2	1	241590400	52,837
5	6	57	10	2	1	241590500	52,837
6	6	57	10	2	1	241590600	52,837
8	8	63	16	2	1	241590800	61,427

$d_1$ h10	$d_2$	$l_1$	$l_2$	Z	pcs	cod.	€ cad/each
10	10	72	19	2	1	241591000	78,401
12	12	83	22	2	1	241591200	117,059
14	14	83	22	2	1	241591400	150,541
16	16	92	26	2	1	241591600	185,058
18	18	92	26	2	1	241591800	222,473
20	20	104	32	2	1	241592000	294,975

# 24179

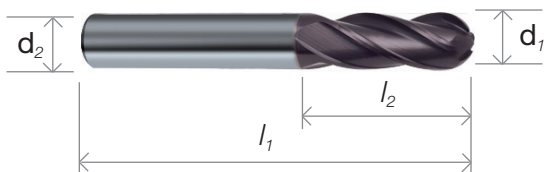

$d_1$ h10	$d_2$	$l_1$	$l_2$	Z	pcs	cod.	€ cad/each
4	4	50	11	4	1	241790400	45,385
5	5	50	13	4	1	241790500	51,957
6	6	57	13	4	1	241790600	56,925
8	8	63	19	4	1	241790800	71,674
10	10	72	22	4	1	241791000	98,739

d h10	$d_2$	$l_1$	$l_2$	Z	pcs	cod.	€ cad/each
12	12	83	26	4	1	241791200	134,861
14	14	83	26	4	1	241791400	165,962
16	16	92	32	4	1	241791600	209,588
18	18	92	32	4	1	241791800	249,228
20	20	104	38	4	1	241792000	325,145

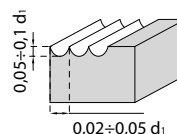
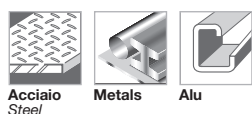

Operazione consigliata /  
Working tips

Frese per copiatori  
Ball nose end mills



## 24158

### Frese frontali a raggio in metallo duro integrale, serie extra lunga

Carbide end mills with ball end / Fraise carbure à bout hémisphérique

Fresas frontales radiales de metal duro / Hartmetall Langlochfräser

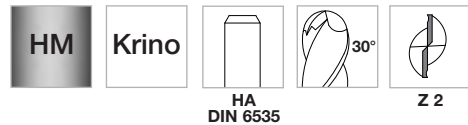

## METALLO DURO/CARBIDE

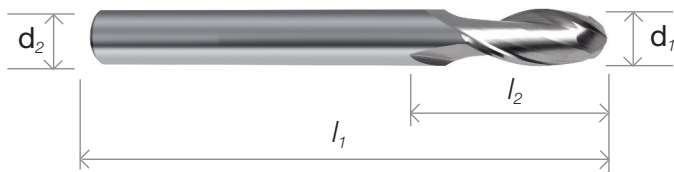

$d_1$ h10	$d_2$	$l_1$	$l_2$	Z	pcs 	cod.	€ cad/each
3	3	75	20	2	1	241580300	84,922
4	4	75	25	2	1	241580400	86,785
5	5	75	30	2	1	241580500	97,083
6	6	75	30	2	1	241580600	108,313
8	8	100	40	2	1	241580800	123,269
10	10	100	40	2	1	241581000	166,221
12	12	150	45	2	1	241581200	220,300

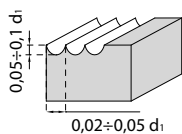

Operazione consigliata /  
Working tips

Frese per copiatori  
Ball nose end mills



Acciai e metalli duri, acciai per lavorazioni a caldo, acciai legati con  $R < 1200 \text{ N/mm}^2$ , acciai dolci, bronzo, ghisa, leghe Al-Si. Structural and case hardened steels, cast steels, heat treatable steels, alloyed steels up to  $R < 1200 \text{ N/mm}^2$ , carbon steels, bronze, cast iron, Al-Si alloys. / Aciers et métaux durs, aciers pour les usinages à chaud, aciers alliés avec  $R < 1200 \text{ N/mm}^2$ , aciers doux, bronze, fonte, alliages Al-Si. / Aceros y metales duros, aceros para trabajos en caliente, aceros aleados con  $R < 1200 \text{ N/mm}^2$ , aceros dulces, bronce, hierro fundido y aleaciones Al-Si.

# 24160

## Frese frontali a raggio in metallo duro integrale, serie extra lunga

Carbide end mills with ball end / Fraise carbure à bout hémisphérique

Fresas frontales radiales de metal duro / Hartmetall Langlochfräser



### METALLO DURO/CARBIDE

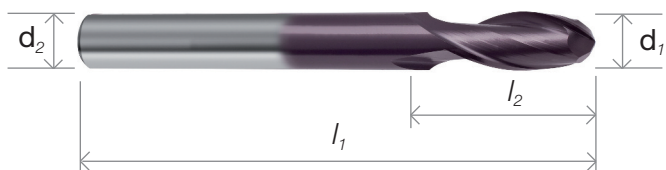

$d_1$ h10	$d_2$	$l_1$	$l_2$	Z	pcs 	cod.	€ cad/each
3	3	75	20	2	1	241600300	101,896
4	4	75	25	2	1	241600400	104,173
5	5	75	30	2	1	241600500	116,489
6	6	75	30	2	1	241600600	129,944
8	8	100	40	2	1	241600800	147,953
10	10	100	40	2	1	241601000	199,445
12	12	150	45	2	1	241601200	264,391

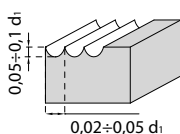

Operazione consigliata /  
Working tips

Frese per copiatori  
Ball nose end mills

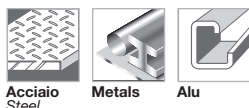

Acciai e metalli duri, acciai per lavorazioni a caldo, acciai legati con  $R < 1200 \text{ N/mm}^2$ , acciai dolci, bronzo, ghisa, leghe Al-Si. Structural and case hardened steels, cast steels, heat treatable steels, alloyed steels up to  $R < 1200 \text{ N/mm}^2$ , carbon steels, bronze, cast iron, Al-Si alloys. / Aciers et métaux durs, aciers pour les usinages à chaud, aciers alliés avec  $R < 1200 \text{ N/mm}^2$ , aciers doux, bronze, fonte, alliages Al-Si. / Aceros y metales duros, aceros para trabajos en caliente, aceros aleados con  $R < 1200 \text{ N/mm}^2$ , aceros dulces, bronce, hierro fundido y aleaciones Al-Si.

## 24177

### Frese frontali per superfinitura in metallo duro integrale, serie lunga

Carbide end mills for superfinishing purpose, TiAlN coated / Fraises a metaux pour super-finition

Fresas frontales para metales para super-acabado

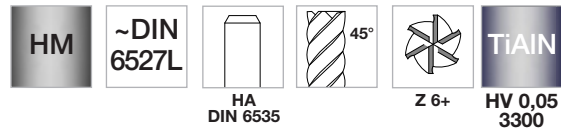

**METALLO DURO/CARBIDE**  
**SPECIALI PER MATERIALI HRC<50**  
**SPECIAL FOR MATERIALS HRC<50**

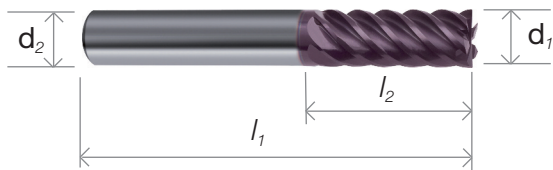

$d_1$ h10	$d_2$	$l_1$	$l_2$	Z	pcs 	cod.	€ cad/each
3	6	57	8	6	1	241770300	55,062
4	6	57	11	6	1	241770400	52,164
5	6	57	13	6	1	241770500	49,991
6	6	57	13	6	1	241770600	49,991
8	8	63	19	6	1	241770800	59,409
10	10	72	22	6	1	241771000	95,634
12	12	83	26	6	1	241771200	128,961
14	14	83	26	6	1	241771400	176,778
16	16	92	32	6	1	241771600	231,840
18	18	92	32	8	1	241771800	270,963
20	20	104	38	8	1	241772000	333,270
25	25	121	45	10	1	241772500	547,722

#### Operazione consigliata / Working tips

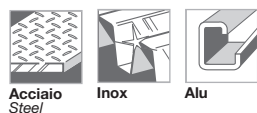
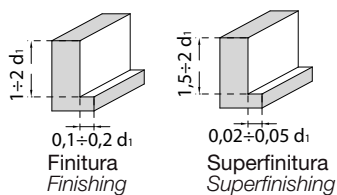

# 24185

## Frese frontali per superfinitura in metallo duro integrale, serie lunga con attacco Weldon

Carbide end mills for superfinishing purpose, TiAlN coated / Fraises a metaux pour super-finition

Fresas frontales para metales para super-acabado

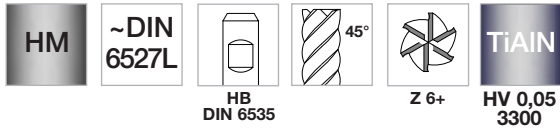

**METALLO DURO/CARBIDE**  
**SPECIALI PER MATERIALI HRC<50**  
**SPECIAL FOR MATERIALS HRC<50**

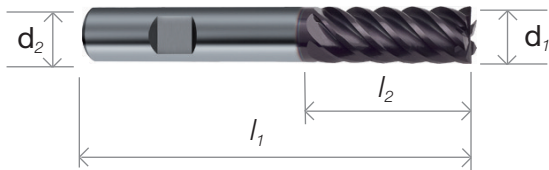

$d_1$ h10	$d_2$	$l_1$	$l_2$	Z	pcs 	cod.	€ cad/each
6	6	57	13	6	1	241850600	53,613
8	8	63	19	6	1	241850800	63,756
10	10	72	22	6	1	241851000	101,430
12	12	83	26	6	1	241851200	134,757
14	14	83	26	6	1	241851400	188,370
16	16	92	32	6	1	241851600	239,085
18	18	92	32	8	1	241851800	281,106
20	20	104	38	8	1	241852000	344,862
25	25	121	45	10	1	241852500	562,212

### Operazione consigliata / Working tips

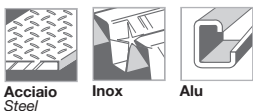
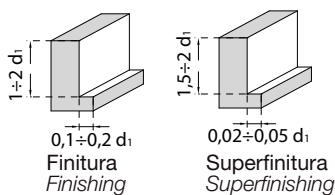

## 24178

### Frese frontali per superfinitura in metallo duro integrale, serie extra lunga

Carbide end mills for superfinishing purpose, TiAlN coated / Fraises a metaux pour super-finition

Fresas frontales para metales para super-acabado

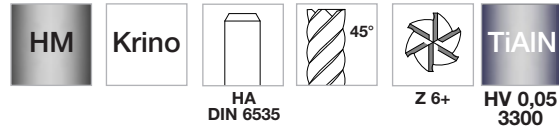

**METALLO DURO/CARBIDE**  
**SPECIALI PER MATERIALI HRC<50**  
**SPECIAL FOR MATERIALS HRC<50**

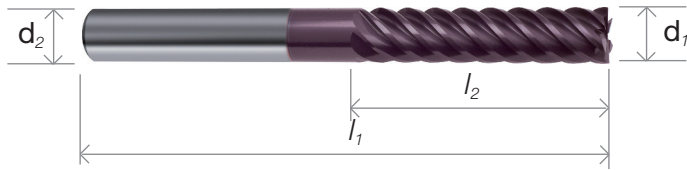

$d_1$ h10	$d_2$	$l_1$	$l_2$	Z	pcs 	cod.	€ cad/each
6	6	75	30	6	1	241780600	86,216
8	8	100	40	6	1	241780800	100,292
10	10	100	40	6	1	241781000	177,710
12	12	150	45	6	1	241781200	246,330
16	16	150	65	6	1	241781600	443,394
20	20	150	65	8	1	241782000	675,648
25	25	150	75	10	1	241782500	1161,270

#### Operazione consigliata / Working tips

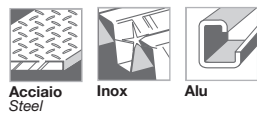
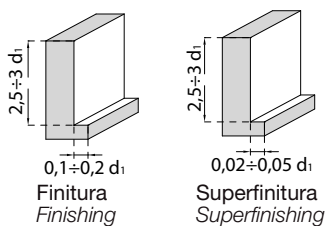

# 24186

## Frese frontali per superfinitura in metallo duro integrale, serie lunga

Carbide end mills for superfinishing purpose, TiAlN coated / Fraises a metaux pour super-finition

Fresas frontales para metales para super-acabado

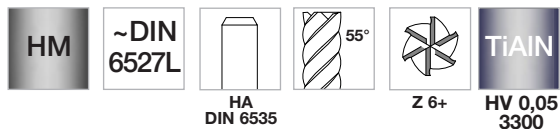

**METALLO DURO/CARBIDE**  
**SPECIALI PER MATERIALI HRC<62**  
**SPECIAL FOR MATERIALS HRC<62**

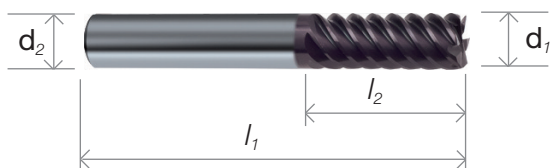

$d_1$ h10	$d_2$	$l_1$	$l_2$	Z	pcs 	cod.	€ cad/each
3	6	57	8	6	1	241860300	47,817
4	6	57	11	6	1	241860400	50,819
5	6	57	13	6	1	241860500	52,009
6	6	57	13	6	1	241860600	52,268
8	8	63	19	6	1	241860800	63,394
10	10	72	22	6	1	241861000	98,532
12	12	83	26	6	1	241861200	130,824
14	14	83	26	6	1	241861400	177,658
16	16	92	32	6	1	241861600	272,464
18	18	92	32	8	1	241861800	267,910
20	20	104	38	8	1	241862000	343,931

### Operazione consigliata / Working tips

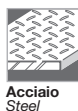
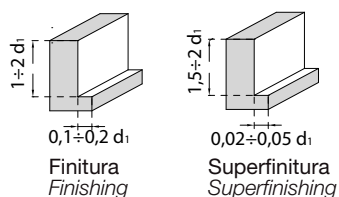

## 24176

### Frese frontali universali a elica variabile in metallo duro integrale

Carbide end mills with variable helix, TiAlN coated / Fraises carbure avec helice variable

Fresas frontales de metal duro con helica variable



## METALLO DURO/CARBIDE

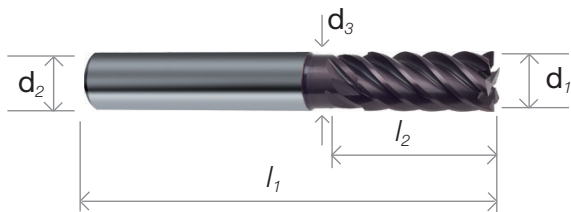

$d_1$ h10	$d_2$	$d_3$	$l_1$	$l_2$	Z	pcs 	cod.	€ cad/each
8	8	7,5	63	19	6	1	241760800	117,421
10	10	9,2	72	22	6	1	241761000	188,474
12	12	11,2	83	26	6	1	241761200	253,316
16	16	15,0	92	32	6	1	241761600	454,210
20	20	19,0	104	38	6	1	241762000	654,948
25	25	23,5	121	45	6	1	241762500	1055,597

#### Operazione consigliata / Working tips

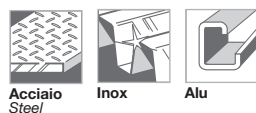
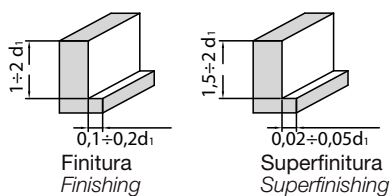

Questi utensili ad elica variabile (44°-45°-46°) sono universali ed adatti alle lavorazioni di superfinitura di tutti i più comuni metalli, con ottimi rendimenti e minime vibrazioni. These universal tools with variable helix angle (44°-45°-46°) are suitable for superfinishing operations into the most common metals, assuring great performances and low vibrations. / Ces outils à hélice variable (44° - 45° - 46°) sont universels et adaptés à l'usinage de super finition de tous les métaux les plus communs, avec d'excellents rendements et peu de vibrations. / Estos utensilios con hélice variable (44°-45°-46°) son universales y aptos para realizar un súper-acabado de los metales más comunes, con óptimos rendimientos y vibraciones mínimas.



## > UTENSILI A FILETTARE

Threading tools  
Outils a fileter  
Utensillos a roscar  
Gewindebohrer und  
Schneideisen

Le operazioni di maschiatura e filettatura assumono un'importanza rilevante nelle lavorazioni industriali. Valgono, per gli utensili a filettare, le stesse considerazioni generali sugli utensili per forare in acciaio superrapido; poiché le lavorazioni di filettatura sono ancora più problematiche, è così chiara la motivazione del grande sviluppo nell'offerta dei maschi e filiere (il capitolo è stato ulteriormente implementato). Pertanto, sono disponibili utensili a filettare in HSS-G e HSS-CO, con una gamma di passi notevolmente ampliata per ciascun articolo e con rivestimenti al TiN e TiAlN per le lavorazioni più difficili. Una vasta gamma di maschi speciali con anello colorato guida l'utente industriale ad una corretta scelta di utilizzo. È stata inoltre sviluppata tutta l'offerta delle filettature non metriche, in modo particolare le filettature americane ed inglesi, mentre è sicuramente esauriente il capitolo delle metriche. Il capitolo si chiude con un programma dettagliato di prodotti per il ripristino delle filettature danneggiate. Sono inoltre disponibili utilissimi set completi di tutti i sistemi di filettatura in comode cassette di legno o metallo, per un sicuro utilizzo ed un facile ricollocamento dopo l'uso.



## 10162

### Maschi a macchina, scanalature diritte, imb. corretto, fil. metrica ISO passo grosso

Machine taps, spiral point, metric thread / Tarauds machine, entrée gun, fil. métrique

Machos de maquina, entrada corregida, rosca metrica / Maschinen-Gewindebohrer für metrisches ISO-Regelgewinde

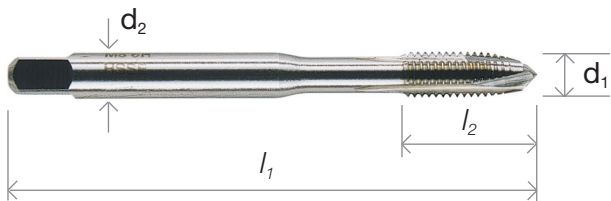
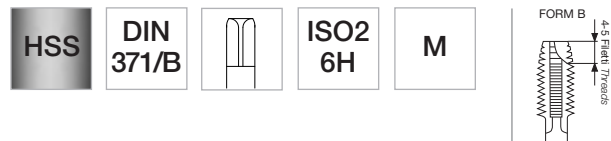

	$d_1$	$l_2$	$l_1$	$d_2$	pcs	cod.	€ cad/each
<b>M 2</b>	x 0,4	8	45	2,8	1	1016202X04	13,993
<b>2,5</b>	x 0,45	9	50	2,8	1	10162025X045	13,993
<b>3</b>	x 0,5	11	56	3,5	1	1016203X05	10,153
<b>3,5</b>	x 0,6	13	56	4	1	10162035X06	16,788
<b>4</b>	x 0,7	13	63	4,5	1	1016204X07	10,247
<b>5</b>	x 0,8	16	70	6	1	1016205X08	10,474
<b>6</b>	x 1	19	80	6	1	1016206X1	10,743
<b>7</b>	x 1	19	80	7	1	1016207X1	15,059
<b>8</b>	x 1,25	22	90	8	1	1016208X125	12,989
<b>10</b>	x 1,5	24	100	10	1	1016210X15	15,059

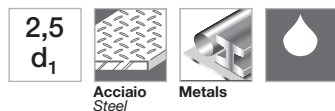
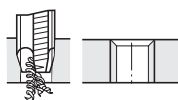

Per fori passanti in acciai con  $R \leq 700 \text{ N/mm}^2$ , ghisa, metalli non ferrosi a truciolo lungo. For through holes in steel with  $R \leq 700 \text{ N/mm}^2$ , cast iron, non ferrous metals with long chip / Pour trous débouchants en acier avec  $R \leq 700 \text{ N/mm}^2$ , fonte, alliages légers. / Para orificios pasantes en materiales de hasta  $R \leq 700 \text{ N/mm}^2$  / Für durchgangsloch in Stahl mit  $R \leq 700 \text{ N/mm}^2$ , Stahlguss, alu langspanend.



14 pcs - M 3÷12

2,5-3,3-4,2-5-6,8-8,5-10,2

10240306 € 102,993



Abs

7 pcs - M 3÷12

10240300 € 83,959

# 10250

## Maschi a macchina, scanalature diritte, imb. corretto, fil. metrica ISO passo grosso

Machine taps, spiral point, metric thread / Tarauds machine, entrée gun, fil. métrique

Machos de maquina, entrada corregida, rosca metrica / Maschinen-Gewindebohrer für metrisches ISO-Regelgewinde

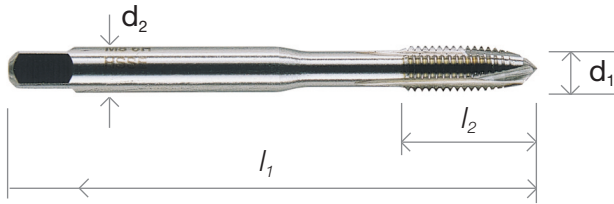
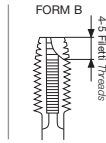
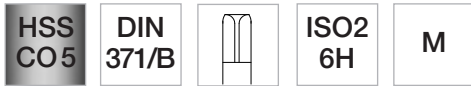

	$d_1$	$l_2$	$l_1$	$d_2$	pcs	cod.	€ cad/each
<b>M 1</b>	x 0,25	5	40	2,5	1	1025001x025	51,750
<b>1,1</b>	x 0,25	5	40	2,5	1	10250011x025	51,750
<b>1,2</b>	x 0,25	5	40	2,5	1	10250012x025	51,750
<b>1,4</b>	x 0,3	7	40	2,5	1	10250014x030	46,575
<b>1,6</b>	x 0,35	8	40	2,5	1	10250016x035	46,575
<b>1,7</b>	x 0,35	8	40	2,5	1	10250017x035	46,575
<b>1,8</b>	x 0,35	8	40	2,5	1	10250018x035	46,575
<b>2</b>	x 0,4	8	45	2,8	1	1025002X04	22,770
<b>2,5</b>	x 0,45	9	50	2,8	1	10250025X045	22,770
<b>3</b>	x 0,5	11	56	3,5	1	1025003X05	12,989
<b>3,5</b>	x 0,6	13	56	4	1	10250035X06	18,754
<b>4</b>	x 0,7	13	63	4,5	1	1025004X07	12,989
<b>5</b>	x 0,8	16	70	6	1	1025005X08	13,289
<b>6</b>	x 1	19	80	6	1	1025006X1	14,045
<b>7</b>	x 1	19	80	7	1	1025007X1	18,806
<b>8</b>	x 1,25	22	90	8	1	1025008X125	16,343
<b>9</b>	x 1,25	22	90	9	1	1025009X125	19,034
<b>10</b>	x 1,5	24	100	10	1	1025010X15	19,034

### MICRO MACHINE TAPS

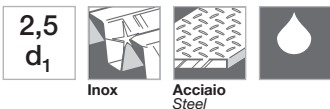
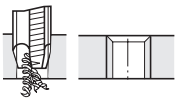

Per fori passanti in acciai con  $R_s \leq 850 \text{ N/mm}^2$ , ghisa, metalli non ferrosi a truciolo lungo. For through holes in steel with  $R_s \leq 850 \text{ N/mm}^2$ , cast iron, non ferrous metals with long chip / Pour trous débouchants en acier avec  $R_s \leq 850 \text{ N/mm}^2$ , fonte, alliages légers. / Para orificios pasantes en materiales de hasta  $R_s \leq 850 \text{ N/mm}^2$  / Für durchgangsloch in Stahl mit  $R_s \leq 850 \text{ N/mm}^2$ , Stahlguss, alu langspanend.



14 pcs - M 3÷12

2,5-3,3-4,2-5-6,8-8,5-10,2

10345306 € 124,200



7 pcs - M 3÷12

10345300 € 105,228

## 10165

Maschi a macchina, scanalature diritte, imb. corretto, fil. metrica ISO passo grosso

Machine taps, spiral point, metric thread / Tarauds machine, entrée gun, fil. métrique

Machos de maquina, entrada corregida, rosca metrica / Maschinen-Gewindebohrer für metrisches ISO-Regelgewinde

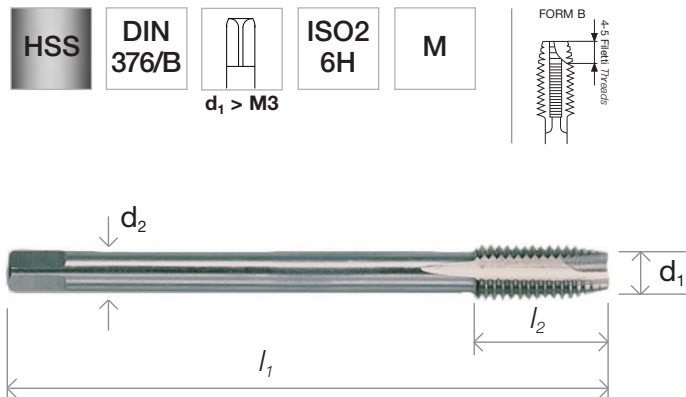

	d <sub>1</sub>	l <sub>2</sub>	l <sub>1</sub>	d <sub>2</sub>	pcs	cod.	€ cad/each		d <sub>1</sub>	l <sub>2</sub>	l <sub>1</sub>	d <sub>2</sub>	pcs	cod.	€ cad/each	
<b>M</b>	3 x 0,5	11	56	2,2	1	1016503X05	11,261		<b>M</b>	22 x 2,5	34	140	18	1	1016522X25	47,724
	4 x 0,7	13	63	2,8	1	1016504X07	11,561			24 x 3	38	160	18	1	1016524X3	56,966
	5 x 0,8	16	70	3,5	1	1016505X08	11,882			27 x 3	38	160	20	1	1016527X3	97,394
	6 x 1	19	80	4,5	1	1016506X1	12,110			30 x 3,5	45	180	22	1	1016530X35	117,545
	8 x 1,25	22	90	6	1	1016508X125	13,020			33 x 3,5	50	180	25	1	1016533X35	145,531
	10 x 1,5	24	100	7	1	1016510X15	15,277			36 x 4	56	200	28	1	1016536X4	173,518
	12 x 1,75	29	110	9	1	1016512X175	17,854			39 x 4	60	200	32	1	1016539X4	221,656
	14 x 2	30	110	11	1	1016514X2	22,439			42 x 4,5	60	200	32	1	1016542X45	249,642
	16 x 2	30	110	12	1	1016516X2	27,334			45 x 4,5	65	220	36	1	1016545X45	291,063
	18 x 2,5	34	125	14	1	1016518X25	37,508			48 x 5	70	250	36	1	1016548X5	353,753
	20 x 2,5	34	140	16	1	1016520X25	39,454			52 x 5	70	250	40	1	1016552X5	395,173

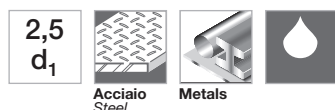

Per fori passanti in acciai con R<sub>s</sub> 700 N/mm<sup>2</sup>, ghisa, metalli non ferrosi a truciolo lungo. For through holes in steel with R<sub>s</sub> 700 N/mm<sup>2</sup>, cast iron, non ferrous metals with long chip / Pour trous débouchants en acier avec R<sub>s</sub> 700 N/mm<sup>2</sup>, fonte, alliages légers. / Para orificios pasantes en materiales de hasta R<sub>s</sub> 700 N/mm<sup>2</sup> / Für durchgangsloch in Stahl mit R<sub>s</sub> 700 N/mm<sup>2</sup>, Stahlguss, alu langspanend.

# 10253

## Maschi a macchina, scanalature diritte, imb. corretto, fil. metrica ISO passo grosso

Machine taps, spiral point, metric thread / Tarauds machine, entrée gun, fil. métrique

Machos de maquina, entrada corregida, rosca metrica / Maschinen-Gewindebohrer für metrisches ISO-Regelgewinde

HSS  
CO 5

DIN  
376/B



ISO 2  
6H

M

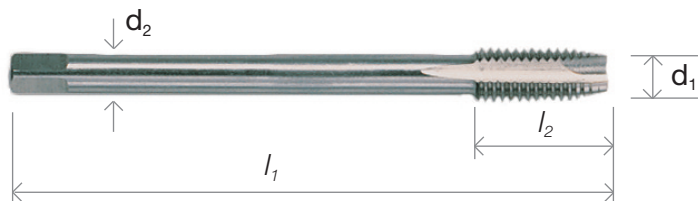
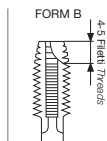

	$d_1$	$l_2$	$l_1$	$d_2$	pcs	cod.	€ cad/each
<b>M</b>	3 x 0,5	11	56	2,2	1	1025303X05	17,140
	4 x 0,7	13	63	2,8	1	1025304X07	17,419
	5 x 0,8	16	70	3,5	1	1025305X08	18,071
	6 x 1	19	80	4,5	1	1025306X1	18,216
	8 x 1,25	22	90	6	1	1025308X125	19,665
	10 x 1,5	24	100	7	1	1025310X15	22,925
	12 x 1,75	29	110	9	1	1025312X175	24,695
	14 x 2	30	110	11	1	1025314X2	34,362
	16 x 2	30	110	12	1	1025316X2	40,437
	18 x 2,5	34	125	14	1	1025318X25	50,715
	20 x 2,5	34	140	16	1	1025320X25	63,911
	22 x 2,5	34	140	18	1	1025322X25	77,118
	24 x 3	38	160	18	1	1025324X3	86,847

	$d_1$	$l_2$	$l_1$	$d_2$	pcs	cod.	€ cad/each
<b>M</b>	27 x 3	38	160	20	1	1025327X3	116,427
	30 x 3,5	45	180	22	1	1025330X35	142,168
	33 x 3,5	50	180	25	1	1025333X35	180,235
	36 x 4	56	200	28	1	1025336X4	201,504
	39 x 4	60	200	32	1	1025339X4	272,029
	42 x 4,5	60	200	32	1	1025342X45	289,935
	45 x 4,5	65	220	36	1	1025345X45	335,837
	48 x 5	70	250	36	1	1025348X5	401,880
	52 x 5	70	250	40	1	1025352X5	467,934
	56 x 5,5	70	250	40	1	1025356X55	1036,615
	60 x 5,5	75	280	45	1	1025360X55	1193,345
	64 x 6	80	315	50	1	1025364X6	1464,246
	68 x 6	80	315	50	1	1025368X6	1585,154



Per fori passanti in acciai con  $R_s \leq 850 \text{ N/mm}^2$ , ghisa, metalli non ferrosi a truciolo lungo. For through holes in steel with  $R_s \leq 850 \text{ N/mm}^2$ , cast iron, non ferrous metals with long chip / Pour trous débouchants en acier avec  $R_s \leq 850 \text{ N/mm}^2$ , fonte, alliages légers. / Para orificios pasantes en materiales de hasta  $R_s \leq 850 \text{ N/mm}^2$  / Für durchgangsloch in Stahl mit  $R_s \leq 850 \text{ N/mm}^2$ , Stahlguss, alu langspanend.

## 10168

Maschi a macchina, scanalature diritte, imb. "C", fil. ISO passo grosso

Machine taps, "C" chamfer form, metric thread / Tarauds machine, entrée "C", filetage métrique

Machos de maquina, entrada "C", rosca métrica / Maschinengewindebohrer für metrisches ISO-Regelgewinde

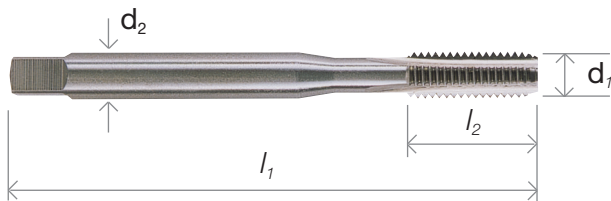
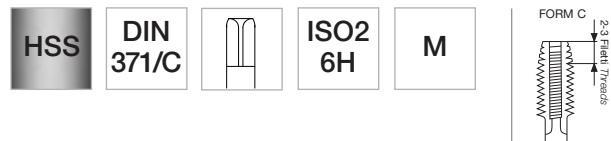

	$d_1$	$l_2$	$l_1$	$d_2$	pcs	cod.	€ cad/each
<b>M 2</b>	x 0,4	8	45	2,8	1	1016802X04	14,128
<b>2,3</b>	x 0,4	9	45	2,8	1	10168023X04	14,128
<b>2,5</b>	x 0,45	9	50	2,8	1	10168025X045	14,128
<b>2,6</b>	x 0,45	9	50	2,8	1	10168026X045	14,128
<b>3</b>	x 0,5	11	56	3,5	1	1016803X05	9,077
<b>3,5</b>	x 0,6	13	56	4	1	10168035X06	14,324
<b>4</b>	x 0,7	13	63	4,5	1	1016804X07	9,077
<b>5</b>	x 0,8	16	70	6	1	1016805X08	9,284
<b>6</b>	x 1	19	80	6	1	1016806X1	9,864
<b>7</b>	x 1	19	80	7	1	1016807X1	12,151
<b>8</b>	x 1,25	22	90	8	1	1016808X125	11,085
<b>10</b>	x 1,5	24	100	10	1	1016810X15	13,320

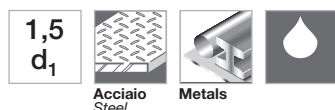

Per fori ciechi e passanti in acciai e ghisa con  $R_s \leq 700 \text{ N/mm}^2$ . For blind and trough holes in steel with  $R_s \leq 700 \text{ N/mm}^2$  / Pour trous débouchants et borgnes en acier avec  $R_s \leq 700 \text{ N/mm}^2$  / Para orificios pasantes y ciegos in acero de hasta  $R_s \leq 700 \text{ N/mm}^2$  / Für grund und durchgangslotch in Stahl, Stahlguss mit  $R_s \leq 700 \text{ N/mm}^2$ .

# 10251

## Maschi a macchina, scanalature diritte, imb. "C", fil. ISO passo grosso

Machine taps, "C" chamfer form, metric thread / Tarauds machine, entrée "C", filetage métrique

Machos de maquina, entrada "C", rosca métrica / Maschinengewindebohrer für metrisches ISO-Regelgewinde

HSS  
CO 5

DIN  
371/C



ISO2  
6H

M

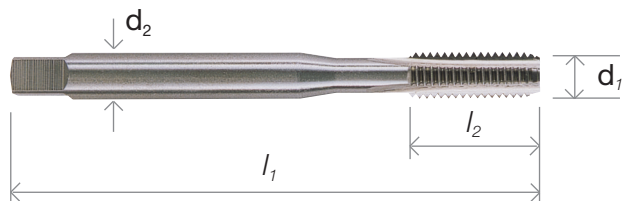
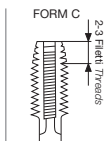

	$d_1$	$l_2$	$l_1$	$d_2$	pcs	cod.	€ cad/each
<b>M 2</b>	x 0,4	8	45	2,8	1	1025102X04	16,705
<b>2,3</b>	x 0,4	9	45	2,8	1	10251023X04	16,705
<b>2,5</b>	x 0,45	9	50	2,8	1	10251025X045	16,705
<b>2,6</b>	x 0,45	9	50	2,8	1	10251026X045	16,705
<b>3</b>	x 0,5	11	56	3,5	1	1025103X05	12,141
<b>3,5</b>	x 0,6	13	56	4	1	10251035X06	12,989
<b>4</b>	x 0,7	13	63	4,5	1	1025104X07	12,141
<b>5</b>	x 0,8	16	70	6	1	1025105X08	12,141
<b>6</b>	x 1	19	80	6	1	1025106X1	12,938
<b>7</b>	x 1	19	80	7	1	1025107X1	16,136
<b>8</b>	x 1,25	22	90	8	1	1025108X125	14,687
<b>10</b>	x 1,5	24	100	10	1	1025110X15	17,264

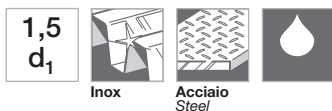

Per fori ciechi e passanti in acciai e ghisa con  $R_s \leq 850 \text{ N/mm}^2$ . For blind and through holes in steel with  $R_s \leq 850 \text{ N/mm}^2$  / Pour trous débouchants et borgnes en acier avec  $R_s \leq 850 \text{ N/mm}^2$  / Para orificios pasantes y ciegos in acero de hasta  $R_s \leq 850 \text{ N/mm}^2$  / Für grund und durchgangslöcher in Stahl, Stahlguss mit  $R_s \leq 850 \text{ N/mm}^2$ .

## 10171

### Maschi a macchina, scanalature diritte, imb. "C", fil. ISO passo grosso

Machine taps, "C" chamfer form, metric thread / Tarauds machine, entrée "C", filetage métrique

Machos de maquina, entrada "C", rosca métrica / Maschinengewindebohrer für metrisches ISO-Regelgewinde

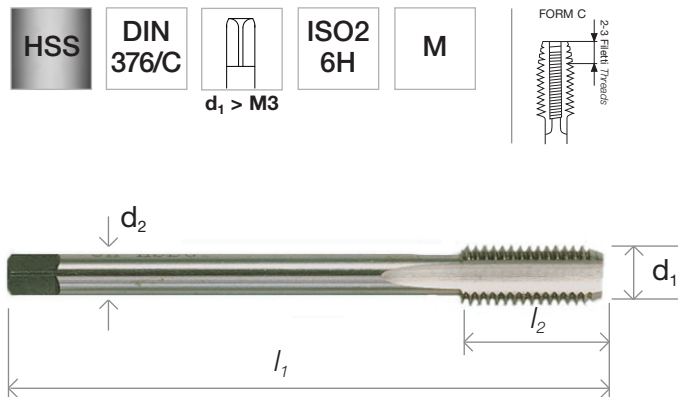

	d <sub>1</sub>	l <sub>2</sub>	l <sub>1</sub>	d <sub>2</sub>	pcs	cod.	€ cad/each		d <sub>1</sub>	l <sub>2</sub>	l <sub>1</sub>	d <sub>2</sub>	pcs	cod.	€ cad/each	
<b>M</b>	3 x 0,5	11	56	2,2	1	1017103X05	10,226		<b>M</b>	22 x 2,5	34	140	18	1	1017122X25	42,880
	4 x 0,7	13	63	2,8	1	1017104X07	10,412			24 x 3	38	160	18	1	1017124X3	46,896
	5 x 0,8	16	70	3,5	1	1017105X08	10,785			27 x 3	38	160	20	1	1017127X3	80,606
	6 x 1	19	80	4,5	1	1017106X1	10,940			30 x 3,5	45	180	22	1	1017130X35	98,511
	8 x 1,25	22	90	6	1	1017108X125	11,758			33 x 3,5	50	180	25	1	1017133X35	126,498
	10 x 1,5	24	100	7	1	1017110X15	13,797			36 x 4	56	200	28	1	1017136X4	141,050
	12 x 1,75	29	110	9	1	1017112X175	16,539			39 x 4	60	200	32	1	1017139X4	183,588
	14 x 2	30	110	11	1	1017114X2	20,421			42 x 4,5	60	200	32	1	1017142X45	204,858
	16 x 2	32	110	12	1	1017116X2	24,033			45 x 4,5	65	220	36	1	1017145X45	235,090
	18 x 2,5	34	125	14	1	1017118X25	33,420			48 x 5	70	250	36	1	1017148X5	282,100
	20 x 2,5	34	140	16	1	1017120X25	35,542			52 x 5	70	250	40	1	1017152X5	333,601

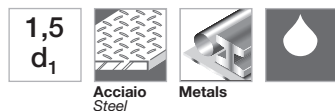
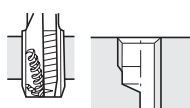

Per fori ciechi e passanti in acciai e ghisa con  $R_s \leq 700 \text{ N/mm}^2$ . For blind and trough holes in steel with  $R_s \leq 700 \text{ N/mm}^2$ . Pour trous débouchants et borgnes en acier avec  $R_s \leq 700 \text{ N/mm}^2$ . / Para orificios pasantes y ciegos en acero de hasta  $R_s \leq 700 \text{ N/mm}^2$ . / Für grund und durchgangsloch in Stahl, Stahlguss mit  $R_s \leq 700 \text{ N/mm}^2$ .

# 10254

## Maschi a macchina, scanalature diritte, imb. "C", fil. ISO passo grosso

Machine taps, "C" chamfer form, metric thread / Tarauds machine, entrée "C", filetage métrique

Machos de maquina, entrada "C", rosca métrica / Maschinengewindebohrer für metrisches ISO-Regelgewinde

HSS  
CO 5

DIN  
376/C



ISO 2  
6H

M

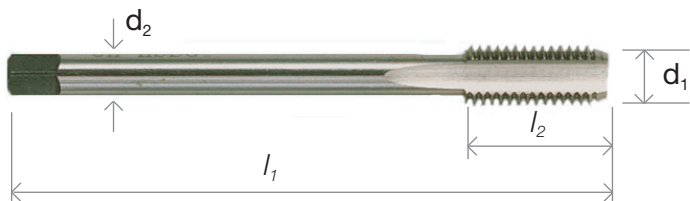
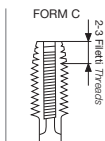

	d <sub>1</sub>	l <sub>2</sub>	l <sub>1</sub>	d <sub>2</sub>	pcs	cod.	€ cad/each
<b>M</b>	3 x 0,5	11	56	2,2	1	1025403X05	14,832
	4 x 0,7	13	63	2,8	1	1025404X07	15,080
	5 x 0,8	16	70	3,5	1	1025405X08	15,618
	6 x 1	19	80	4,5	1	1025406X1	15,773
	8 x 1,25	22	90	6	1	1025408X125	17,906
	10 x 1,5	24	100	7	1	1025410X15	20,886
	12 x 1,75	29	110	9	1	1025412X175	25,109
	14 x 2	30	110	11	1	1025414X2	31,298
	16 x 2	32	110	12	1	1025416X2	36,815
	18 x 2,5	34	125	14	1	1025418X25	45,851
	20 x 2,5	34	140	16	1	1025420X25	58,095

	d <sub>1</sub>	l <sub>2</sub>	l <sub>1</sub>	d <sub>2</sub>	pcs	cod.	€ cad/each
<b>M</b>	22 x 2,5	34	140	18	1	1025422X25	70,163
	24 x 3	38	160	18	1	1025424X3	79,271
	27 x 3	38	160	20	1	1025427X3	104,804
	30 x 3,5	45	180	22	1	1025430X35	127,616
	33 x 3,5	50	180	25	1	1025433X35	164,565
	36 x 4	56	200	28	1	1025436X4	183,588
	39 x 4	60	200	32	1	1025439X4	238,443
	42 x 4,5	60	200	32	1	1025442X45	266,430
	45 x 4,5	65	220	36	1	1025445X45	305,615
	48 x 5	70	250	36	1	1025448X5	367,187
	52 x 5	70	250	40	1	1025452X5	434,348

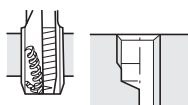

Per fori ciechi e passanti in acciai e ghisa con R<sub>s</sub> 850 N/mm<sup>2</sup>. For blind and trough holes in steel with R<sub>s</sub> 850 N/mm<sup>2</sup> Pour trous débouchants et borgnes en acier avec R<sub>s</sub> 850 N/mm<sup>2</sup> / Para orificios pasantes y ciegos in acero de hasta R<sub>s</sub> 850 N/mm<sup>2</sup> / Für grund und durchgangsloch in Stahl, Stahlguss mit R<sub>s</sub> 850 N/mm<sup>2</sup>.



## 10174

Maschi a macchina, scanalature destre 15°, imb. "C", fil. metrica ISO passo grosso.

Machine taps, 15° spiral flute, metric thread / Tarauds machine, goujures 15°, filetage métrique

Machos de maquina, canal helicoidal a 15°, rosca metrica / Maschinen-gewindebohrer, 15° rechtsspirale, für metrisches ISO-Regelgewinde

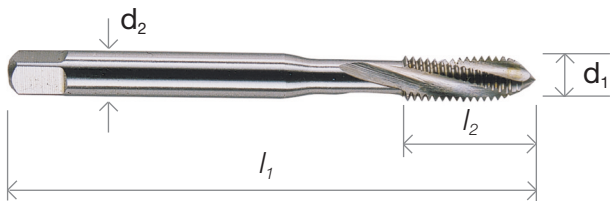
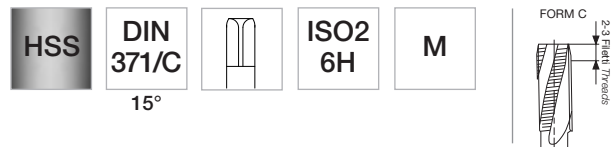

	d <sub>1</sub>	l <sub>2</sub>	l <sub>1</sub>	d <sub>2</sub>	pcs	cod.	€ cad/each
<b>M</b>	3 x 0,5	11	56	3,5	1	1017403X05	11,685
	4 x 0,7	13	63	4,5	1	1017404X07	11,923
	5 x 0,8	16	70	6	1	1017405X08	12,037
	6 x 1	19	80	6	1	1017406X1	12,441
	8 x 1,25	22	90	8	1	1017408X125	13,724
	10 x 1,5	24	100	10	1	1017410X15	16,363

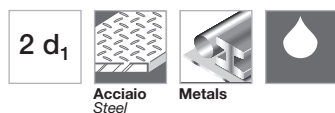
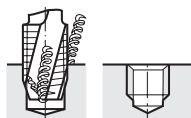

Per fori ciechi in acciai con R<sub>s</sub> 700 N/mm<sup>2</sup>, ghisa malleabile, metalli non ferrosi a truciolo lungo.  
 For blind holes in steel with R<sub>s</sub> 700 N/mm<sup>2</sup>, malleable cast iron, non ferrous metals with long chip. /  
 Pour trous borgnes en acier avec R<sub>s</sub> 700 N/mm<sup>2</sup>, fonte, alliages légers. / Para orificios ciegos en acero  
 de hasta R<sub>s</sub> 700 N/mm<sup>2</sup>, aleaciones ligeras, fundiciones. / Für Sackloch in Stahl mit R<sub>s</sub> 700 N/mm<sup>2</sup>,  
 Stahlguss, alu langspanend.



14 pcs - M 3÷12

2,5-3,3-4,2-5-6,8-8,5-10,2

10240312 € 105,228



Abs

7 pcs - M 3÷12

10240311 € 85,077

# 10256

Maschi a macchina, scanalature destre 15°, imb. "C", fil. metrica ISO passo grosso.

Machine taps, 15° spiral flute, metric thread / Tarauds machine, goujures 15°, filetage métrique

Machos de maquina, canal helicoidal a 15°, rosca metrica / Maschinen-gewindebohrer, 15° rechtsspirale, für metrisches ISO-Regelgewinde

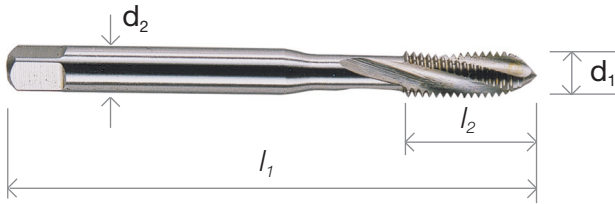
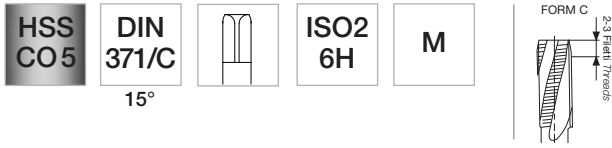

	d <sub>1</sub>	l <sub>2</sub>	l <sub>1</sub>	d <sub>2</sub>	pcs	cod.	€ cad/each
<b>M</b>	3 x 0,5	11	56	3,5	1	1025603X05	15,980
	4 x 0,7	13	63	4,5	1	1025604X07	15,980
	5 x 0,8	16	70	6	1	1025605X08	15,980
	6 x 1	19	80	6	1	1025606X1	16,819
	8 x 1,25	22	90	8	1	1025608X125	18,382
	10 x 1,5	24	100	10	1	1025610X15	21,642

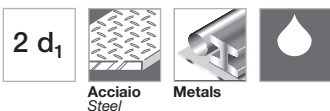
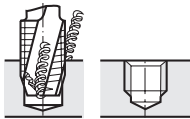

Per fori ciechi in acciai con R<sub>s</sub> 850 N/mm<sup>2</sup>, ghisa malleabile, metalli non ferrosi a truciolo lungo.  
 For blind holes in steel with R<sub>s</sub> 850 N/mm<sup>2</sup>, malleable cast iron, non ferrous metals with long chip. /  
 Pour trous borgnes en acier avec R<sub>s</sub> 850 N/mm<sup>2</sup>, fonte, alliages légers. / Para orificios ciegos en acero  
 de hasta R<sub>s</sub> 850 N/mm<sup>2</sup>, aleaciones ligeras, fundiciones. / Für Sackloch in Stahl mit R<sub>s</sub> 850 N/mm<sup>2</sup>,  
 Stahlguss, alu langspanend.



14 pcs - M 3÷12

2,5-3,3-4,2-5-6,8-8,5-10,2

10345312 € 151,131



Abs

7 pcs - M 3÷12

10345311 € 119,781

## 10177

Maschi a macchina, scanalature destre 15°, imb. "C", fil. metrica ISO passo grosso.

Machine taps, 15° spiral flute, metric thread / Tarauds machine, goujures 15°, filetage métrique

Machos de maquina, canal helicoidal a 15°, rosca metrica / Maschinen-gewindebohrer, 15° rechtsspirale, für metrisches ISO-Regelgewinde

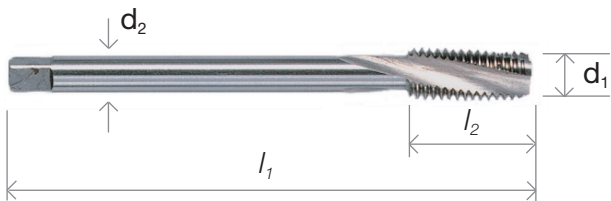
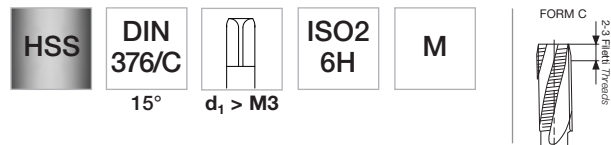

$d_1$	$l_2$	$l_1$	$d_2$	pcs 	cod.	€ cad/each
<b>M 3</b> x 0,5	11	56	2,2	1	1017703X05	12,648
<b>4</b> x 0,7	13	63	2,8	1	1017704X07	13,300
<b>5</b> x 0,8	16	70	3,5	1	1017705X08	13,434
<b>6</b> x 1	19	80	4,5	1	1017706X1	13,652
<b>8</b> x 1,25	22	90	6	1	1017708X125	14,614
<b>10</b> x 1,5	24	100	7	1	1017710X15	18,723
<b>12</b> x 1,75	29	110	9	1	1017712X175	21,249
<b>14</b> x 2	30	110	11	1	1017714X2	26,020
<b>16</b> x 2	30	110	12	1	1017716X2	30,367
<b>18</b> x 2,5	34	125	14	1	1017718X25	40,851
<b>20</b> x 2,5	34	140	16	1	1017720X25	43,491
<b>22</b> x 2,5	34	140	18	1	1017722X25	52,640
<b>24</b> x 3	38	160	18	1	1017724X3	56,946

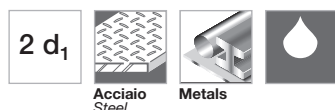
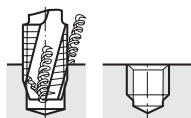

Per fori ciechi in acciai con  $R_s \leq 700 \text{ N/mm}^2$ , ghisa malleabile, metalli non ferrosi a truciolo lungo. For blind holes in steel with  $R_s \leq 700 \text{ N/mm}^2$ , malleable cast iron, non ferrous metals with long chip. / Pour trous borgnes en acier avec  $R_s \leq 700 \text{ N/mm}^2$ , fonte, alliages légers. / Para orificios ciegos en acero de hasta  $R_s \leq 700 \text{ N/mm}^2$ , aleaciones ligeras, fundiciones. / Für Sackloch in Stahl mit  $R_s \leq 700 \text{ N/mm}^2$ , Stahlguss, alu langspanend.

# 10258

Maschi a macchina, scanalature destre 15°, imb. "C", fil. metrica ISO passo grosso.

Machine taps, 15° spiral flute, metric thread / Tarauds machine, goujures 15°, filetage métrique

Machos de maquina, canal helicoidal a 15°, rosca metrica / Maschinen-gewindebohrer, 15° rechtsspirale, für metrisches ISO-Regelgewinde

HSS  
CO 5

DIN  
376/C



15°

$d_1 > M3$

ISO 2  
6H

M

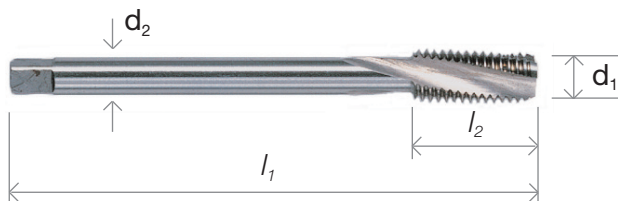
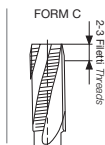

$d_1$	$l_2$	$l_1$	$d_2$	pcs 	cod.	€ cad/each
M 3 x 0,5	11	56	2,2	1	1025803X05	16,767
4 x 0,7	13	63	2,8	1	1025804X07	17,574
5 x 0,8	16	70	3,5	1	1025805X08	17,574
6 x 1	19	80	4,5	1	1025806X1	18,382
8 x 1,25	22	90	6	1	1025808X125	19,665
10 x 1,5	24	100	7	1	1025810X15	24,633
12 x 1,75	29	110	9	1	1025812X175	28,017
14 x 2	30	110	11	1	1025814X2	35,438
16 x 2	30	110	12	1	1025816X2	41,328
18 x 2,5	34	125	14	1	1025818X25	54,814
20 x 2,5	34	140	16	1	1025820X25	58,302
22 x 2,5	34	140	18	1	1025822X25	70,887
24 x 3	38	160	18	1	1025824X3	75,917

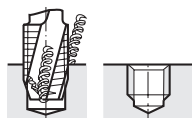

Per fori ciechi in acciai con  $R_s \leq 850 \text{ N/mm}^2$ , ghisa malleabile, metalli non ferrosi a truciolo lungo. For blind holes in steel with  $R_s \leq 850 \text{ N/mm}^2$ , malleable cast iron, non ferrous metals with long chip. / Pour trous borgnes en acier avec  $R_s \leq 850 \text{ N/mm}^2$ , fonte, alliages légers. / Para orificios ciegos en acero de hasta  $R_s \leq 850 \text{ N/mm}^2$ , aleaciones ligeras, fundiciones. / Für Sackloch in Stahl mit  $R_s \leq 850 \text{ N/mm}^2$ , Stahlguss, alu langspanend.

## 10183

### Maschi a macchina, scanalature destre 35°, imb. "C", fil. metrica ISO

Machine taps, 35° spiral flute, metric coarse thread / Tarauds machine, goujures 35°, filetage métrique gros. / Machos de maquina, canal helicoidal 35°, rosca metrica vasta / Maschinen-Gewindebohrer, 35° rechtsspirale, für metrisches ISO-Regelgewinde

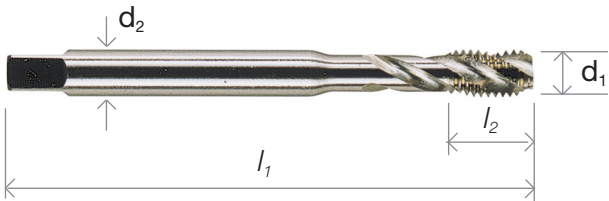
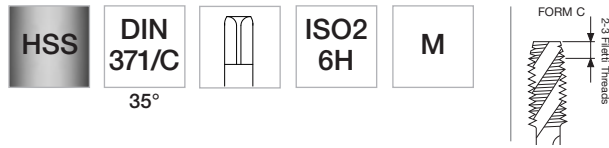

	d <sub>1</sub>	l <sub>2</sub>	l <sub>1</sub>	d <sub>2</sub>	pcs	cod.	€ cad/each
<b>M 2</b>	x 0,4	6	45	2,8	1	1018302X04	22,884
<b>2,5</b>	x 0,45	6	50	2,8	1	10183025X045	22,884
<b>3</b>	x 0,5	6	56	3,5	1	1018303X05	13,186
<b>3,5</b>	x 0,6	13	56	4	1	10183035X06	18,837
<b>4</b>	x 0,7	7	63	4,5	1	1018304X07	13,186
<b>5</b>	x 0,8	8	70	6	1	1018305X08	13,320
<b>6</b>	x 1	10	80	6	1	1018306X1	13,941
<b>7</b>	x 1	19	80	7	1	1018307X1	19,665
<b>8</b>	x 1,25	14	90	8	1	1018308X125	15,287
<b>10</b>	x 1,5	16	100	10	1	1018310X15	18,288

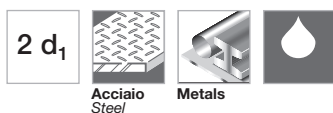
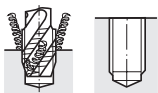

Per fori ciechi in acciai con R<sub>s</sub> 700 N/mm<sup>2</sup> ghisa malleabile, metalli non ferrosi a truciolo lungo, acciai resistenti al calore, acciai inox. For blind holes in steel with R<sub>s</sub> 700 N/mm<sup>2</sup> malleable cast iron, non ferrous metal with long chips, stainless steel, heat resistant steel. / Pour trous borgnes en acier avec R<sub>s</sub> 700 N/mm<sup>2</sup> fonte, alliages légers, acier inoxydable. / Para orificios ciegos in acero de hasta R<sub>s</sub> 700 N/mm<sup>2</sup> aleaciones ligeras, fundicion, acero aleado y acero inox. / Für grundloch in Stahl mit R<sub>s</sub> 700 N/mm<sup>2</sup>, Stahlguss, alu langspanend, korrosions-beständige Stähle (V2A-V4A) etc.



14 pcs - M 3÷12  
DIN 371/B+371/C 35°  
10240310 € 176,871



7 pcs - M 3÷12  
10240305 € 100,747

14 pcs - M 3÷12  
2,5-3,3-4,2-5-6,8-8,5-10,2  
10240307 € 114,181

# 10255

## Maschi a macchina, scanalature destre 35°, imb. "C", fil. metrica ISO

Machine taps, 35° spiral flute, metric coarse thread / Tarauds machine, goujures 35°, filetage métrique gros.

Machos de maquina, canal helicoidal 35°, rosca metrica vasta / Maschinen-Gewindebohrer, 35° rechtsspirale, für metrisches ISO-Regelgewinde

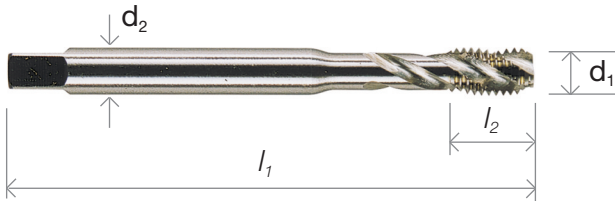
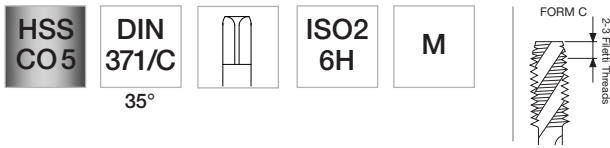

	$d_1$	$l_2$	$l_1$	$d_2$	pcs	cod.	€ cad/each
<b>M 1</b>	x 0,25	4	40	2,5	1	1025501x025	64,170
<b>1,1</b>	x 0,25	4	40	2,5	1	10255011x025	64,170
<b>1,2</b>	x 0,25	4	40	2,5	1	10255012x025	64,170
<b>1,4</b>	x 0,30	5	40	2,5	1	10255014x030	57,960
<b>1,6</b>	x 0,35	6	40	2,5	1	10255016x035	57,960
<b>1,7</b>	x 0,35	6	40	2,5	1	10255017x035	57,960
<b>1,8</b>	x 0,35	6	40	2,5	1	10255018x035	57,960
<b>2</b>	x 0,4	6	45	2,8	1	1025502X04	26,910
<b>2,5</b>	x 0,45	6	50	2,8	1	10255025X045	26,910
<b>3</b>	x 0,5	6	56	3,5	1	1025503X05	18,858
<b>3,5</b>	x 0,6	13	56	4	1	10255035X06	24,902
<b>4</b>	x 0,7	7	63	4,5	1	1025504X07	18,858
<b>5</b>	x 0,8	8	70	6	1	1025505X08	19,003
<b>6</b>	x 1	10	80	6	1	1025506X1	19,872
<b>7</b>	x 1	19	80	7	1	1025507X1	28,980
<b>8</b>	x 1,25	14	90	8	1	1025508X125	21,766
<b>9</b>	x 1,25	14	90	9	1	1025509X125	26,061
<b>10</b>	x 1,5	16	100	10	1	1025510X15	26,061

### MICRO MACHINE TAPS

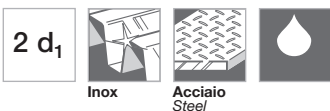
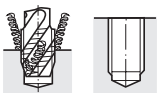

Per fori ciechi in acciai con  $R_s \leq 850 \text{ N/mm}^2$  ghisa malleabile, metalli non ferrosi a truciolo lungo, acciai resistenti al calore, acciai inox. For blind holes in steel with  $R_s \leq 850 \text{ N/mm}^2$  malleable cast iron, non ferrous metal with long chips, stainless steel, heat resistant steel. / Pour trous borgnes en acier avec  $R_s \leq 850 \text{ N/mm}^2$  fonte, alliages légers, acier inoxydable. / Para orificios ciegos in acero de hasta  $R_s \leq 850 \text{ N/mm}^2$  aleaciones ligeras, fundicion, acero aleado y acero inox. / Für grundloch in Stahl mit  $R_s \leq 850 \text{ N/mm}^2$ , Stahlguss, alu langspanend, korrosions-beständige Stähle (V2A-V4A) etc.



14 pcs - M 3÷12  
DIN 371/B+371/C 35°  
10345310 € 226,127



7 pcs - M 3÷12  
10345305 € 129,861

14 pcs - M 3÷12  
2,5-3,3-4,2-5-6,8-8,5-10,2  
10345307 € 156,720

## 10180

Maschi a macchina, scanalature destre 35°, imb. "C", fil. metrica ISO

Machine taps, 35° spiral flute, metric coarse thread / Tarauds machine, goujures 35°, filetage métrique gros.

Machos de maquina, canal helicoidal 35°, rosca metrica vasta / Maschinen-Gewindebohrer, 35° rechtsspirale, für metrisches ISO-Regelgewinde

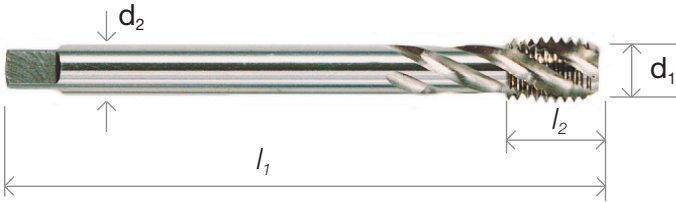
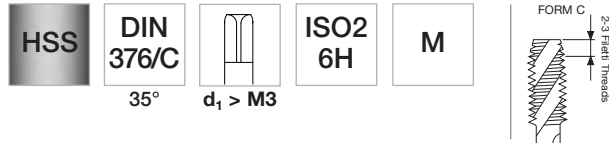

d <sub>1</sub>	l <sub>2</sub>	l <sub>1</sub>	d <sub>2</sub>	pcs	cod.	€ cad/each
M 3 x 0,5	5	56	2,2	1	1018003X05	14,656
4 x 0,7	7	63	2,8	1	1018004X07	14,656
5 x 0,8	8	70	3,5	1	1018005X08	14,852
6 x 1	10	80	4,5	1	1018006X1	15,111
8 x 1,25	13	90	6	1	1018008X125	16,011
10 x 1,5	15	100	7	1	1018010X15	20,007
12 x 1,75	18	110	9	1	1018012X175	23,298
14 x 2	20	110	11	1	1018014X2	29,508
16 x 2	22	110	12	1	1018016X2	35,904
18 x 2,5	25	125	14	1	1018018X25	47,237
20 x 2,5	25	140	16	1	1018020X25	52,164

d <sub>1</sub>	l <sub>2</sub>	l <sub>1</sub>	d <sub>2</sub>	pcs	cod.	€ cad/each
M 22 x 2,5	25	140	18	1	1018022X25	64,025
24 x 3	30	160	18	1	1018024X3	69,666
27 x 3	30	160	20	1	1018027X3	104,111
30 x 3,5	35	180	22	1	1018030X35	126,498
33 x 3,5	35	180	25	1	1018033X35	153,366
36 x 4	40	200	28	1	1018036X4	181,353
39 x 4	40	200	32	1	1018039X4	236,208
42 x 4,5	45	200	32	1	1018042X45	268,665
45 x 4,5	45	220	36	1	1018045X45	301,133
48 x 5	50	250	36	1	1018048X5	341,436
52 x 5	50	250	40	1	1018052X5	405,244

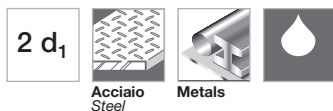
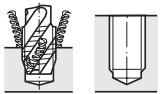

Per fori ciechi in acciai con R<sub>s</sub> 700 N/mm<sup>2</sup> ghisa malleabile, metalli non ferrosi a truciolo lungo, acciai resistenti al calore, acciai inox. For blind holes in steel with R<sub>s</sub> 700 N/mm<sup>2</sup> malleable cast iron, non ferrous metal with long chips, stainless steel, heat resistant steel. / Pour trous borgnes en acier avec R<sub>s</sub> 700 N/mm<sup>2</sup> fonte, alliages légers, acier inoxydable. / Para orificios ciegos in acero de hasta R<sub>s</sub> 700 N/mm<sup>2</sup> aleaciones ligeras, fundicion, acero aleado y acero inox. / Für grundloch in Stahl mit R<sub>s</sub> 700 N/mm<sup>2</sup>, Stahlguss, alu langspanend, korrosions-beständige Stähle (V2A-V4A) etc.

# 10257

## Maschi a macchina, scanalature destre 35°, imb. "C", fil. metrica ISO

Machine taps, 35° spiral flute, metric coarse thread / Tarauds machine, goujures 35°, filetage métrique gros.

Machos de maquina, canal helicoidal 35°, rosca metrica vasta / Maschinen-Gewindebohrer, 35° rechtsspirale, für metrisches ISO-Regelgewinde

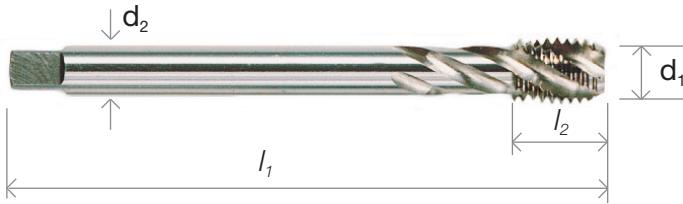
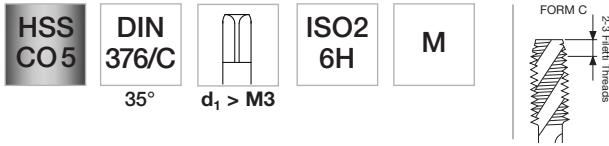

d <sub>1</sub>	l <sub>2</sub>	l <sub>1</sub>	d <sub>2</sub>	pcs	cod.	€ cad/each
M 3 x 0,5	5	56	2,2	1	1025703X05	19,758
4 x 0,7	7	63	2,8	1	1025704X07	20,741
5 x 0,8	8	70	3,5	1	1025705X08	20,741
6 x 1	10	80	4,5	1	1025706X1	20,741
8 x 1,25	13	90	6	1	1025708X125	22,573
10 x 1,5	15	100	7	1	1025710X15	28,204
12 x 1,75	18	110	9	1	1025712X175	33,306
14 x 2	20	110	11	1	1025714X2	42,104
16 x 2	22	110	12	1	1025716X2	51,243
18 x 2,5	25	125	14	1	1025718X25	67,389
20 x 2,5	25	140	16	1	1025720X25	71,063
22 x 2,5	25	140	18	1	1025722X25	87,282
24 x 3	30	160	18	1	1025724X3	94,972

d <sub>1</sub>	l <sub>2</sub>	l <sub>1</sub>	d <sub>2</sub>	pcs	cod.	€ cad/each
M 27 x 3	30	160	20	1	1025727X3	139,932
30 x 3,5	35	180	22	1	1025730X35	171,282
33 x 3,5	35	180	25	1	1025733X35	207,104
36 x 4	40	200	28	1	1025736X4	244,043
39 x 4	40	200	32	1	1025739X4	319,049
42 x 4,5	45	200	32	1	1025742X45	363,823
45 x 4,5	45	220	36	1	1025745X45	406,362
48 x 5	50	250	36	1	1025748X5	461,217
52 x 5	50	250	40	1	1025752X5	547,412
56 x 5,5	70	250	40	1	1025756X55	1195,580
60 x 5,5	70	280	45	1	1025760X55	1371,334
64 x 6	75	315	50	1	1025764X6	1687,019
68 x 6	75	315	50	1	1025768X6	1826,951

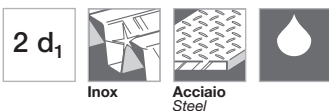
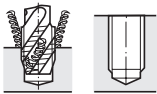

Per fori ciechi in acciai con R<sub>s</sub> 850 N/mm<sup>2</sup> ghisa malleabile, metalli non ferrosi a truciolo lungo, acciai resistenti al calore, acciai inox. For blind holes in steel with R<sub>s</sub> 850 N/mm<sup>2</sup> malleable cast iron, non ferrous metal with long chips, stainless steel, heat resistant steel. / Pour trous borgnes en acier avec R<sub>s</sub> 850 N/mm<sup>2</sup> fonte, alliages légers, acier inoxydable. / Para orificios ciegos in acero de hasta R<sub>s</sub> 850 N/mm<sup>2</sup> aleaciones ligeras, fundicion, acero aleado y acero inox. / Für grundloch in Stahl mit R<sub>s</sub> 850 N/mm<sup>2</sup>, Stahlguss, alu langspanend, korrosions-beständige Stähle (V2A-V4A) etc.



## 10273

### Maschi a macchina per dadi, filettatura metrica ISO a passo grosso.

Machine nut taps, metric coarse thread / Tarauds machine à l'enfilade, filetage métrique

Machos de maquina, tipo tuercas, rosca metrica / Maschinen-muttergewindebohrer, metrisches Regel-Gewinde

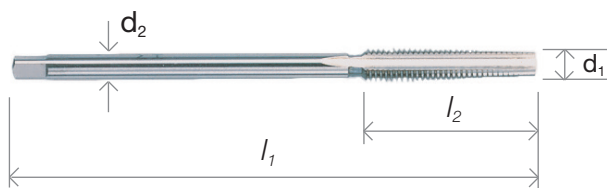
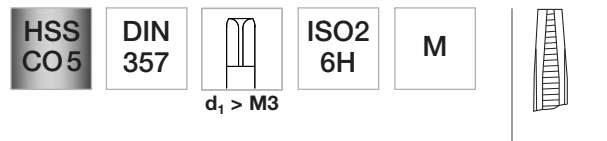

	$d_1$	$l_2$	$l_1$	$d_2$	pcs 	cod.	€ cad/each
<b>M</b>	3 x 0,5	22	70	2,2	1	1027303X05	17,512
	4 x 0,7	25	90	2,8	1	1027304X07	17,512
	5 x 0,8	28	100	3,5	1	1027305X08	18,702
	6 x 1	32	110	4,5	1	1027306X1	19,562
	8 x 1,25	40	125	6	1	1027308X125	25,492
	10 x 1,5	45	140	7	1	1027310X15	29,280
	12 x 1,75	50	180	9	1	1027312X175	37,664
	14 x 2	56	200	11	1	1027314X2	49,463
	16 x 2	63	200	12	1	1027316X2	60,113
	18 x 2,5	63	220	14	1	1027318X25	69,997
	20 x 2,5	70	250	16	1	1027320X25	79,478
	22 x 2,5	80	280	18	1	1027322X25	94,030
	24 x 3	80	280	18	1	1027324X3	110,828

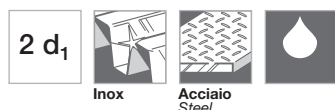
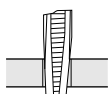

Per fori passanti in acciai con  $R_s \leq 850 \text{ N/mm}^2$ , ghisa, metalli non ferrosi. For through holes in steel with  $R_s \leq 850 \text{ N/mm}^2$ , cast iron, non ferrous metals / Pour trous débouchants en acier avec  $R_s \leq 850 \text{ N/mm}^2$ , fonte, alliages légers. / Para orificios pasantes en materiales de hasta  $R_s \leq 850 \text{ N/mm}^2$  / Für durchgangsloch in Stahl mit  $R_s \leq 850 \text{ N/mm}^2$ , Stahlguss.

# 10290

## Punta-Maschio a macchina per forature e filettature in una sola operazione.

Combined machine drill-tap for drilling and threading in one operation / Foret tarauteur à machine, filetage métrique

Brocas-macho, rosca métrica normal / Maschinen-kombi-Gewindebohrer für metrisches ISO Regel-Gewinde

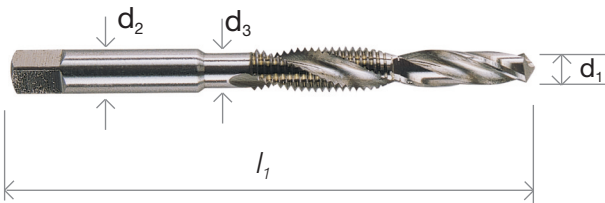
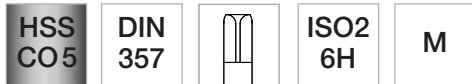

	$d_1$	$l_1$	$d_3$	$d_2$	pcs 	cod.	€ cad/each
<b>M 3</b> x 0,5	56	2,5	3	1	1029003X05	48,366	
<b>4</b> x 0,7	63	3,3	4	1	1029004X07	48,366	
<b>5</b> x 0,8	71	4,2	5	1	1029005X08	48,366	
<b>6</b> x 1	80	5	6	1	1029006X1	53,634	
<b>8</b> x 1,25	95	6,8	8	1	1029008X125	58,840	
<b>10</b> x 1,5	106	8,5	10	1	1029010X15	66,043	
<b>12</b> x 1,75	115	10,2	12	1	1029012X175	78,919	

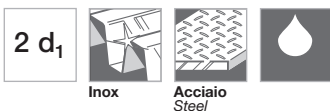
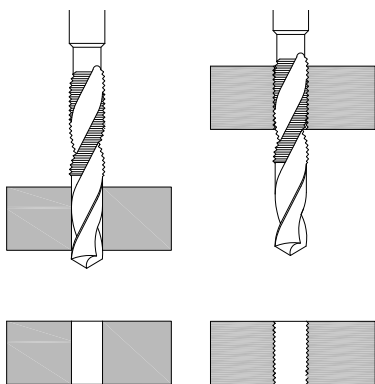

Per forare e filettare in acciai con  $R_s \leq 850$  N/mm<sup>2</sup>, metalli non ferrosi, acciai resistenti al calore, acciai inox. Drilling and threading into steel with  $R_s \leq 850$  N/mm<sup>2</sup>, non ferrous metals, stainless steel, heat resistant steel. / Parcage et taraudage en unique operation en acier avec  $R_s \leq 850$  N/mm<sup>2</sup>, alliages legers, acier inoxydable. Para taladra y rosacar acero  $R_s \leq 850$  N/mm<sup>2</sup>, acero aleado, acero inox. / Kernlochbohren, Gewindeschneiden in Stahl mit  $R_s \leq 850$  N/mm<sup>2</sup>, Stahlguss.

## 10212

Utensile combinato con attacco esagonale per avvitatori e trapani reversibili Combined bits for drilling-threading-deburring in one operation with 1/4" hexagon drive / Outil combiné pour perçage-taraudage-ebavurage en unique operation / Utensilio combinado para taladrar – roscar y avellanar en una sola operacion / Kombi-bits zum kerlochbohren, gewindeschneiden und entgraten in einen Arbeitsgang

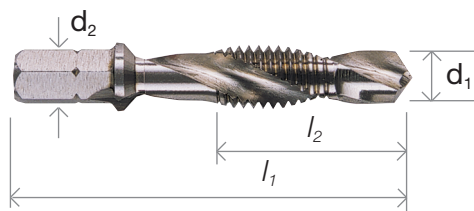

$d_1$	$l_2$	$l_1$	$d_2$	pcs	cod.	€ cad/each
<b>M 3 x 0,5</b>	2,5	36	1/4	1	1021203x05	8,756
<b>4 x 0,7</b>	3,3	39	1/4	1	1021204x07	8,756
<b>5 x 0,8</b>	4,2	41	1/4	1	1021205x08	8,756
<b>6 x 1</b>	5	44	1/4	1	1021206x1	8,756
<b>8 x 1,25</b>	6,8	50	1/4	1	1021208x125	9,988
<b>10 x 1,5</b>	8,5	59	1/4	1	1021210x15	9,988

## 10230

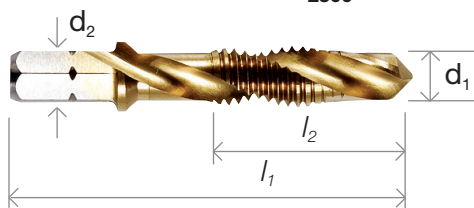

$d_1$	$l_2$	$l_1$	$d_2$	pcs	cod.	€ cad/each
<b>M 3 x 0,5</b>	2,5	36	1/4	1	1023003x05	14,169
<b>4 x 0,7</b>	3,3	39	1/4	1	1023004x07	14,169
<b>5 x 0,8</b>	4,2	41	1/4	1	1023005x08	14,169
<b>6 x 1</b>	5	44	1/4	1	1023006x1	14,169
<b>8 x 1,25</b>	6,8	50	1/4	1	1023008x125	18,568
<b>10 x 1,5</b>	8,5	59	1/4	1	1023010x15	18,568

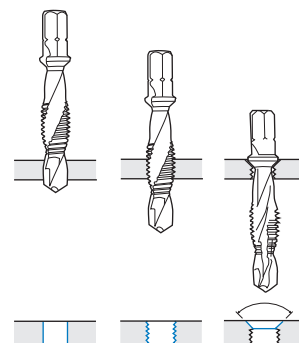

Per forare, filettare e svasare in acciaio, alluminio, metalli non ferrosi in genere, plastica sino a  $R_s \leq 600 \text{ N/mm}^2$  e profondità 1xD. Drilling, threading and deburring in steel, aluminium, plastics with  $R_s \leq 600 \text{ N/mm}^2$  and depth 1xD. - Perçage – taraudage, ebavurage en unique operation en acier, aluminium, plastic avec  $R_s \leq 600 \text{ N/mm}^2$  et spessore de travaille 1xD. / Para taladrar, roscar y avellanar acero, aluminio, plastico con  $R_s \leq 600 \text{ N/mm}^2$  y profundidad de corte 1xD. / Kernlochbohren, gewindeschneiden und entgraten in einem arbeitsgang in Stahl-ne-Metalle-Kunststoffe-bis 600 N/mm<sup>2</sup> zugfestigkeit bis 1xD Materialstärke.

# 10210

## Maschi con attacco esagonale 1/4 per filettare con avvitatori e trapani reversibili

Threading bits with 1/4" hex drive / Tarauds avec 6 pans de 1/4"

Machos a roscar con mango esagonal 1/4" / Einschnittgewindebohrer-bits

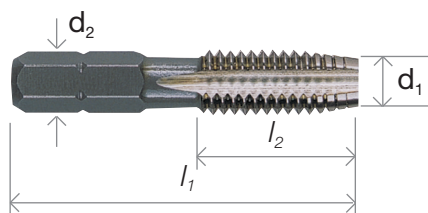

$d_1$	$l_2$	$l_1$	$d_2$ Hex	pcs 	cod.	€ cad/each
M 3 x 0,5	11	33	1/4	1	1021003x05	8,518
4 x 0,7	12	35	1/4	1	1021004x07	8,518
5 x 0,8	15	36	1/4	1	1021005x08	9,305
6 x 1	18	39	1/4	1	1021006x1	9,305
8 x 1,25	19	40	1/4	1	1021008x125	10,091
10 x 1,5	21	41	1/4	1	1021010x15	10,091



Per filettare in acciaio, alluminio, metalli non ferrosi in genere, plastica sino a  $R \leq 600$  N/mm<sup>2</sup> e profondità 1xD. Threading into steel, aluminium, plastics with  $R \leq 600$  N/mm<sup>2</sup> and depth 1xD. / Taraudage en acier, aluminium, plastic avec  $R \leq 600$  N/mm<sup>2</sup>, et spesseur de travaille 1xD. / Para roscar acero, aluminio, plastico  $R \leq 600$  N/mm<sup>2</sup> y profundida de corte 1xD. / Gewindeschneiden in einem arbeitsgang in Stahl-ne-Metalle-Kunststoffe-bis  $R \leq 600$  N/mm<sup>2</sup> zugfestigkeit bis 1xD Materialstärke.

## 10261

### Maschi a macchina, cave diritte e filetti alternati, imb. corretto, fil. metrica ISO

Machine taps, straight flutes, interrupted threads, spiral point / Tarauds machine, goujures droites, entrée B-gun, filets alternés / Machos de maquina, entrada tipo "B" y dientes alternados / Maschinen-gewindebohrer, schälanschnitt form "B", ausgesetzten Zahnen

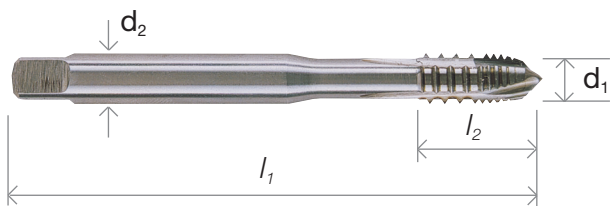
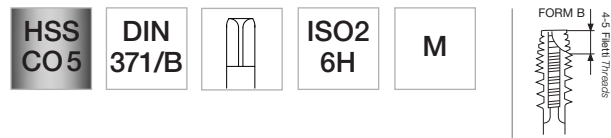

	$d_1$	$l_2$	$l_1$	$d_2$	pcs	cod.	€ cad/each
<b>M</b>	3 x 0,5	11	56	3,5	1	1026103X05	19,148
	4 x 0,7	13	63	4,5	1	1026104X07	19,148
	5 x 0,8	16	70	6	1	1026105X08	20,493
	6 x 1	19	80	6	1	1026106X1	20,493
	8 x 1,25	22	90	8	1	1026108X125	25,151
	10 x 1,5	24	100	10	1	1026110X15	30,015

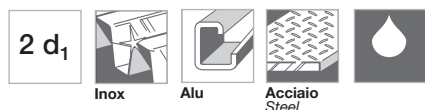
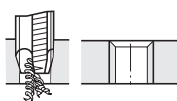

Per filettature in fori passanti in acciai con  $R \geq 900 \text{ N/mm}^2$ , acciai da bonifica e cementazione, acciai inox, materiali di difficile truciolabilità, acciai da utensile, bronzi e leghe di rame, alluminio e leghe, materiali sintetici duri. For through holes in steel with  $R \geq 900 \text{ N/mm}^2$ , high alloy steel, tool steel, stainless steel, bronze, hard sinterized materials. / Pour trous débouchants en acier avec  $R \geq 900 \text{ N/mm}^2$ , acier allié et acier construction, fonte, bronze, matériel synthétique. / Para orificios pasantes en aceros con  $R \geq 900 \text{ N/mm}^2$ , acero aleado, acero inox, bronce, aluminio y aleaciones ligeras. / Für durchgangsloch in Stahl mit  $R \geq 900 \text{ N/mm}^2$ , werkzeuge Stähle, Bronze, rostfreie Stähle, alu langspanend und kurzspanend.

# 10262

## Maschi a macchina, cave diritte e filetti alternati, imb. corretto, fil. metrica ISO

Machine taps, straight flutes, interrupted threads, spiral point / Tarauds machine, goujures droites, entrée B-gun, filets alternés / Machos de maquina, entrada tipo "B" y dientes alternados / Maschinen-gewindebohrer, schälanschnitt form "B", ausgesetzten Zahnen

HSS  
CO5

DIN  
376/B



$d_1 > M3$

ISO2  
6H

M

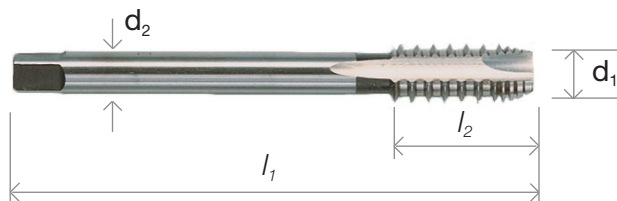
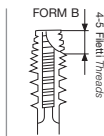

	$d_1$	$l_2$	$l_1$	$d_2$	pcs 	cod.	€ cad/each
<b>M</b>	3 x 0,5	11	56	2,2	1	1026203X05	20,607
	4 x 0,7	13	63	2,8	1	1026204X07	20,607
	5 x 0,8	16	70	3,5	1	1026205X08	21,652
	6 x 1	19	80	4,5	1	1026206X1	21,652
	8 x 1,25	22	90	6	1	1026208X125	26,082
	10 x 1,5	24	100	7	1	1026210X15	31,298
	12 x 1,75	29	110	9	1	1026212X175	36,256
	14 x 2	30	110	11	1	1026214X2	46,948
	16 x 2	30	110	12	1	1026216X2	52,164
	18 x 2,5	34	125	14	1	1026218X25	74,592
	20 x 2,5	34	140	16	1	1026220X25	100,933
	22 x 2,5	34	140	18	1	1026222X25	116,065
	24 x 3	38	160	18	1	1026224X3	123,890

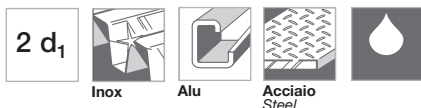
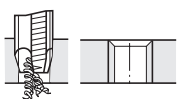

Per filettature in fori passanti in acciai con  $R \geq 900 \text{ N/mm}^2$ , acciai da bonifica e cementazione, acciai inox, materiali di difficile truciolabilità, acciai da utensile, bronzi e leghe di rame, alluminio e leghe, materiali sintetici duri. For through holes in steel with  $R \geq 900 \text{ N/mm}^2$ , high alloy steel, tool steel, stainless steel, bronze, hard sinterized materials. / Pour trous debouchants en acier avec  $R \geq 900 \text{ N/mm}^2$ , acier allié et acier construction, fonte, bronze, matériel synthétique. / Para orificios pasantes en aceros con  $R \geq 900 \text{ N/mm}^2$ , acero aleado, acero inox, bronce, aluminio y aleaciones ligeras. / Für durchgangsloch in Stahl mit  $R \geq 900 \text{ N/mm}^2$ , werkzeuge Stähle, Bronze, rostfreie Stähle, alu langspanend und kurzpanend.

## 10172

### Maschi a macchina "corti" ISO 529

Short machine taps ISO 529 / Tarauds machine courte ISO 529

Machos de maquina cortos ISO 529 / Kurzmaschinen-Gewindebohrer

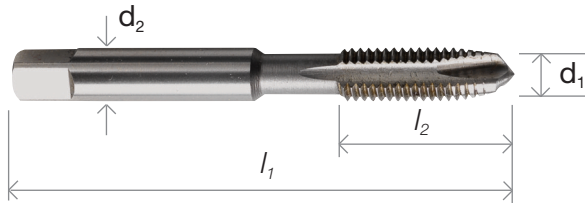
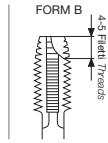

	$d_1$	$l_2$	$l_1$	$d_2$	pcs	cod.	€ cad/each
<b>M 2</b>	x 0,4	8	41	2,5	1	1017202X04	16,984
<b>2,5</b>	x 0,45	9,5	44,5	2,8	1	10172025X045	16,984
<b>2,6</b>	x 0,45	9,5	44,5	2,9	1	10172026X045	16,984
<b>3</b>	x 0,5	11	48	3,15	1	1017203X05	10,040
<b>3,5</b>	x 0,6	13	50	3,55	1	10172035X06	10,712
<b>4</b>	x 0,7	13	53	4	1	1017204X07	10,040
<b>5</b>	x 0,8	16	58	5	1	1017205X08	11,882
<b>6</b>	x 1	19	66	6,3	1	1017206X1	11,882
<b>8</b>	x 1,25	22	72	8	1	1017208X125	13,714
<b>10</b>	x 1,5	24	80	10	1	1017210X15	17,378
<b>12</b>	x 1,75	29	89	9	1	1017212X175	23,753

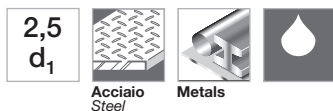
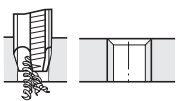

Per fori passanti in acciai con  $R_s \leq 700 \text{ N/mm}^2$ , ghisa, metalli non ferrosi. For through holes in steel with  $R_s \leq 700 \text{ N/mm}^2$ , cast iron, non ferrous metals / Pour trous débouchants en acier avec  $R_s \leq 700 \text{ N/mm}^2$ , fonte, alliages légers. / Para orificios pasantes en materiales de hasta  $R_s \leq 700 \text{ N/mm}^2$  / Für durchgangsloch in Stahl mit  $R_s \leq 700 \text{ N/mm}^2$ , Stahlguss.



7 pcs - M 3÷12

10240313

€ 91,598

# 10173

## Maschi a macchina "corti" ISO 529

Short machine taps ISO 529 / Tarauds machine courte ISO 529

Machos de maquina cortos ISO 529 / Kurzmaschinen-Gewindebohrer

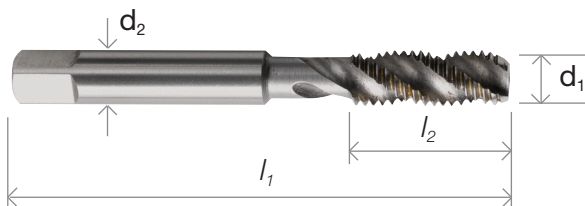
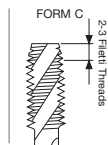

	$d_1$	$l_2$	$l_1$	$d_2$	pcs	cod.	€ cad/each
<b>M 2,5</b> x 0,45	9,5	44,5	2,8	1	10173025X045	22,325	
<b>2,6</b> x 0,45	9,5	44,5	2,9	1	10173026X045	22,325	
<b>3</b> x 0,5	11	48	3,15	1	1017303X05	14,128	
<b>4</b> x 0,7	13	53	4	1	1017304X07	14,128	
<b>5</b> x 0,8	16	58	5	1	1017305X08	14,666	
<b>6</b> x 1	19	66	6,3	1	1017306X1	14,666	
<b>8</b> x 1,25	22	72	8	1	1017308X125	16,498	
<b>10</b> x 1,5	24	80	10	1	1017310X15	21,528	
<b>12</b> x 1,75	29	89	9	1	1017312X175	29,249	

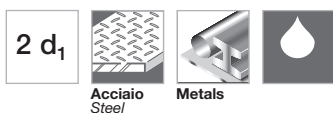
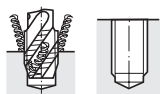

Per fori ciechi in acciai con  $R_s \leq 700$  N/mm<sup>2</sup> ghisa malleabile, metalli non ferrosi a truciolo lungo. For blind holes in steel with  $R_s \leq 700$  N/mm<sup>2</sup> malleable cast iron, non ferrous metal with long chips. / Pour trous borgnes en acier avec  $R_s \leq 700$  N/mm<sup>2</sup> fonte, alliages légers. / Para orificios ciegos in acero de hasta  $R_s \leq 700$  N/mm<sup>2</sup> aleaciones ligeras, fundicion. / Für grundloch in Stahl mit  $R_s \leq 700$  N/mm<sup>2</sup>, Stahlguss, alu langspanend.



7 pcs - M 3÷12

10240314

€ 105,415



## 10310

### Maschi a macchina "sovradimensionati", fil. DIN 13 a passo grosso

Machine taps oversize / Tarauds machine surdimensionné

Machos de maquina sobredimensionados / Gewindebohrer übergroß

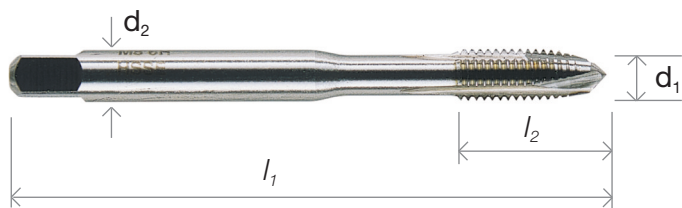
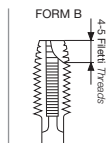
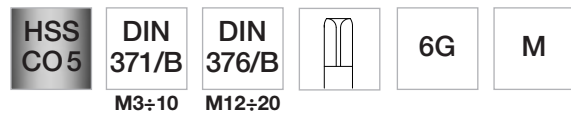

$d_1$      $l_2$      $l_1$      $d_2$     pcs    cod.    €  
    cad/each

#### DIN 371/B

<b>M 3</b>	x 0,5	11	56	3,5	1	1031003X05	18,775
<b>4</b>	x 0,7	13	63	4,5	1	1031004X07	18,775
<b>5</b>	x 0,8	16	70	6	1	1031005X08	19,562
<b>6</b>	x 1	19	80	6	1	1031006X1	19,562
<b>8</b>	x 1,25	22	90	8	1	1031008X125	23,991
<b>10</b>	x 1,5	24	100	10	1	1031010X15	27,386

#### DIN 376/B

<b>M12</b>	x 1,75	29	110	9	1	1031012X175	32,861
<b>14</b>	x 2	30	110	11	1	1031014X2	46,948
<b>16</b>	x 2	32	110	12	1	1031016X2	54,772
<b>18</b>	x 2,5	34	125	14	1	1031018X25	74,334
<b>20</b>	x 2,5	34	140	16	1	1031020X25	104,328

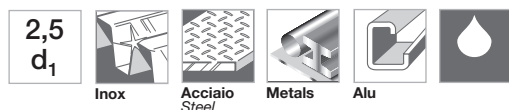

Per filettature in acciai con  $R_s \leq 850 \text{ N/mm}^2$ , ghisa, metalli non ferrosi. For threading in steel with  $R_s \leq 850 \text{ N/mm}^2$ , cast iron, non ferrous metals / Pour taraudage en acier avec  $R_s \leq 850 \text{ N/mm}^2$ , fonte, alliages légers. / Para roscados en materiales de hasta  $R_s \leq 850 \text{ N/mm}^2$ . / Für Gewinde Stahl mit  $R_s \leq 850 \text{ N/mm}^2$ , Stahlguss.

# 10311

## Maschi a macchina "sovradimensionati", fil. DIN 13 a passo grosso

Machine taps oversize / Tarauds machine surdimensionné

Machos de maquina sobredimensionados / Gewindebohrer übergroß

HSS  
CO5

DIN  
371/B  
M3÷10

DIN  
376/B  
M12



7G

M

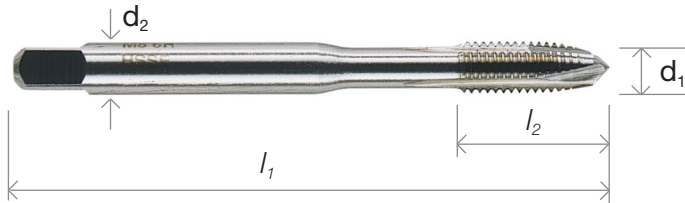
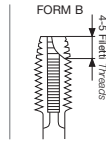

$d_1$      $l_2$      $l_1$      $d_2$     pcs    cod.    €  
    cad/each

### DIN 371/B

<b>M 3</b>	x 0,5	11	56	3,5	1	1031103X05	19,044
<b>4</b>	x 0,7	13	63	4,5	1	1031104X07	19,044
<b>5</b>	x 0,8	16	70	6	1	1031105X08	20,079
<b>6</b>	x 1	19	80	6	1	1031106X1	20,079
<b>8</b>	x 1,25	22	90	8	1	1031108X125	25,295
<b>10</b>	x 1,5	24	100	10	1	1031110X15	30,253

### DIN 376/B

<b>M12</b>	x 1,75	29	110	9	1	1031112X175	34,952
------------	--------	----	-----	---	---	-------------	--------

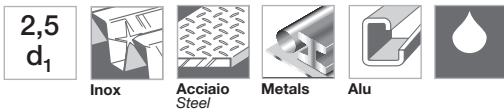
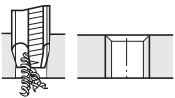

Per filettature in acciai con  $R_s \leq 850 \text{ N/mm}^2$ , ghisa, metalli non ferrosi. For threading in steel with  $R_s \leq 850 \text{ N/mm}^2$ , cast iron, non ferrous metals / Pour taraudage en acier avec  $R_s \leq 850 \text{ N/mm}^2$ , fonte, alliages légers. / Para roscados en materiales de hasta  $R_s \leq 850 \text{ N/mm}^2$ . / Für Gewinde Stahl mit  $R_s \leq 850 \text{ N/mm}^2$ , Stahlguss.

## 10312

### Maschi a macchina "sovradimensionati", fil. DIN 13 a passo grosso

Machine taps oversize / Tarauds machine surdimensionné

Machos de maquina sobredimensionados / Gewindebohrer übergroß

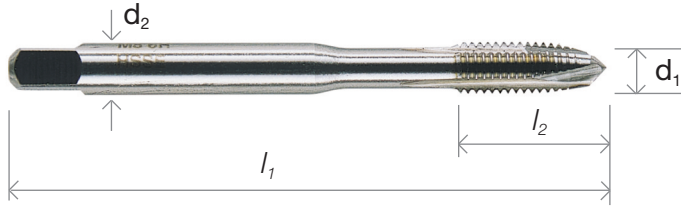
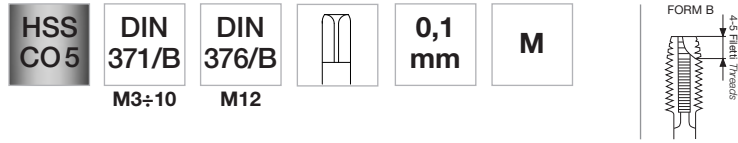

$d_1$      $l_2$      $l_1$      $d_2$     pcs    cod.    €  
    cad/each

#### DIN 371/B

<b>M 3</b>	x 0,5	11	56	3,5	1	1031203X05	19,044
<b>4</b>	x 0,7	13	63	4,5	1	1031204X07	19,044
<b>5</b>	x 0,8	16	70	6	1	1031205X08	20,079
<b>6</b>	x 1	19	80	6	1	1031206X1	20,079
<b>8</b>	x 1,25	22	90	8	1	1031208X125	25,295
<b>10</b>	x 1,5	24	100	10	1	1031210X15	30,253

#### DIN 376/B

<b>M12</b>	x 1,75	29	110	9	1	1031212X175	34,952
------------	--------	----	-----	---	---	-------------	--------

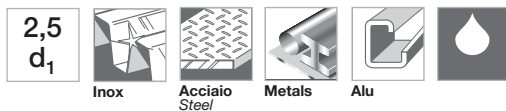
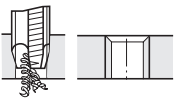

Per filettature in acciai con  $R_s \leq 850$  N/mm<sup>2</sup>, ghisa, metalli non ferrosi. For threading in steel with  $R_s \leq 850$  N/mm<sup>2</sup>, cast iron, non ferrous metals / Pour taraudage en acier avec  $R_s \leq 850$  N/mm<sup>2</sup>, fonte, alliages légers. / Para roscados en materiales de hasta  $R_s \leq 850$  N/mm<sup>2</sup>. / Für Gewinde Stahl mit  $R_s \leq 850$  N/mm<sup>2</sup>, Stahlguss.

# 10313

## Maschi a macchina "sovradimensionati", fil. DIN 13 a passo grosso

Machine taps oversize / Tarauds machine surdimensionné

Machos de maquina sobredimensionados / Gewindebohrer übergroß

HSS  
CO5

DIN  
371/C

35°  
M3÷10

DIN  
376/C

35°  
M12÷20



6G

M

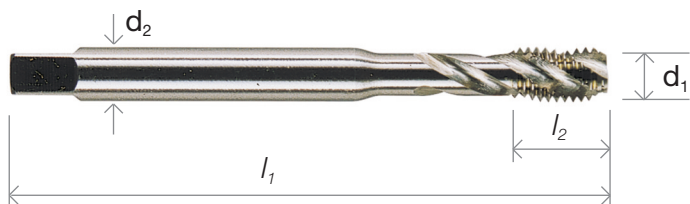
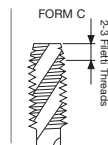

$d_1$      $l_2$      $l_1$      $d_2$     pcs    cod.    €  
    cad/each

### DIN 371/C-35°

<b>M 3</b>	x 0,5	6	56	3,5	1	1031303X05	22,428
<b>4</b>	x 0,7	7	63	4,5	1	1031304X07	22,428
<b>5</b>	x 0,8	8	70	6	1	1031305X08	23,474
<b>6</b>	x 1	10	80	6	1	1031306X1	23,474
<b>8</b>	x 1,25	14	90	8	1	1031308X125	28,690
<b>10</b>	x 1,5	16	100	10	1	1031310X15	33,120

### DIN 376/C-35°

<b>M12</b>	x 1,75	29	110	9	1	1031312X175	35,728
<b>14</b>	x 2	30	110	11	1	1031314X2	51,377
<b>16</b>	x 2	32	110	12	1	1031316X2	54,255
<b>18</b>	x 2,5	34	125	14	1	1031318X25	80,854
<b>20</b>	x 2,5	34	140	16	1	1031320X25	113,457

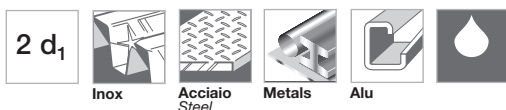
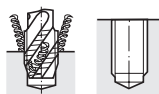

Per filettature in acciai con  $R_s \leq 850 \text{ N/mm}^2$ , ghisa, metalli non ferrosi a truciolo lungo. For threading in steel with  $R_s \leq 850 \text{ N/mm}^2$ , cast iron, non ferrous metals with long chip / Pour taraudage en acier avec  $R_s \leq 850 \text{ N/mm}^2$ , fonte, alliages légers. / Para roscados en materiales de hasta  $R_s \leq 850 \text{ N/mm}^2$ . / Für Gewinde Stahl mit  $R_s \leq 850 \text{ N/mm}^2$ , Stahlguss, alu Langspanend.

## 10314

### Maschi a macchina "sovradimensionati", fil. DIN 13 a passo grosso

Machine taps oversize / Tarauds machine surdimensionné

Machos de maquina sobredimensionados / Gewindebohrer übergroß

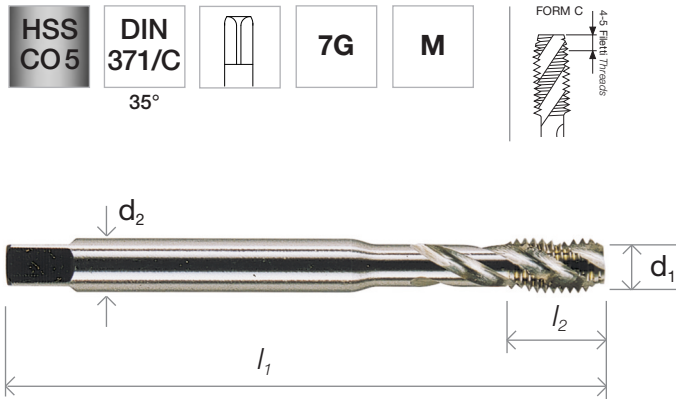

$d_1$      $l_2$      $l_1$      $d_2$     pcs    cod.    €  
    cad/each

#### DIN 371/C-35°

<b>M 3</b>	x 0,5	6	56	3,5	1	1031403X05	<a href="#">22,956</a>
<b>4</b>	x 0,7	7	63	4,5	1	1031404X07	<a href="#">22,956</a>
<b>5</b>	x 0,8	8	70	6	1	1031405X08	<a href="#">24,778</a>
<b>6</b>	x 1	10	80	6	1	1031406X1	<a href="#">24,778</a>
<b>8</b>	x 1,25	14	90	8	1	1031408X125	<a href="#">31,557</a>
<b>10</b>	x 1,5	16	100	10	1	1031410X15	<a href="#">37,301</a>

#### DIN 376/C-35°

<b>M12</b>	x 1,75	18	110	9	1	1031412X175	<a href="#">40,168</a>
------------	--------	----	-----	---	---	-------------	------------------------

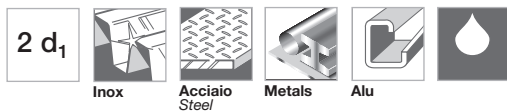
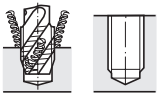

Per filettature in acciai con  $R_s \leq 850$  N/mm<sup>2</sup>, ghisa, metalli non ferrosi a truciolo lungo. For threading in steel with  $R_s \leq 850$  N/mm<sup>2</sup>, cast iron, non ferrous metals with long chip / Pour taraudage en acier avec  $R_s \leq 850$  N/mm<sup>2</sup>, fonte, alliages légers. / Para roscados en materiales de hasta  $R_s \leq 850$  N/mm<sup>2</sup>. / Für Gewinde Stahl mit  $R_s \leq 850$  N/mm<sup>2</sup>, Stahlguss, alu Langspanend.

# 10315

## Maschi a macchina "sovradimensionati", fil. DIN 13 a passo grosso

Machine taps oversize / Tarauds machine surdimensionné

Machos de maquina sobredimensionados / Gewindebohrer übergroß

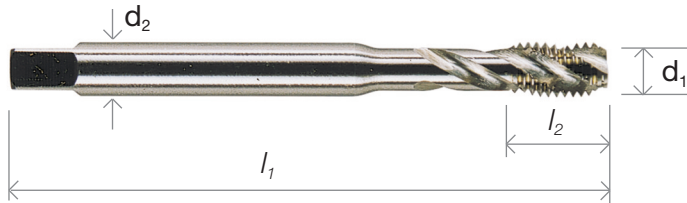

$d_1$      $l_2$      $l_1$      $d_2$     pcs    cod.    €  
    cad/each

### DIN 371/C-35°

<b>M 3</b>	x 0,5	6	56	3,5	1	1031503X05	22,956
<b>4</b>	x 0,7	7	63	4,5	1	1031504X07	22,956
<b>5</b>	x 0,8	8	70	6	1	1031505X08	24,778
<b>6</b>	x 1	10	80	6	1	1031506X1	24,778
<b>8</b>	x 1,25	14	90	8	1	1031508X125	31,557
<b>10</b>	x 1,5	16	100	10	1	1031510X15	37,301

### DIN 376/C-35°

<b>M12</b>	x 1,75	18	110	9	1	1031512X175	40,427
------------	--------	----	-----	---	---	-------------	--------

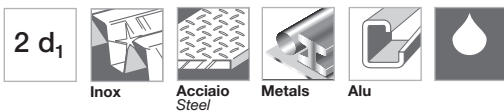
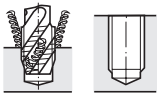

Per filettature in acciai con  $R_s \leq 850$  N/mm<sup>2</sup>, ghisa, metalli non ferrosi a truciolo lungo. For threading in steel with  $R_s \leq 850$  N/mm<sup>2</sup>, cast iron, non ferrous metals with long chip / Pour taraudage en acier avec  $R_s \leq 850$  N/mm<sup>2</sup>, fonte, alliages légers. / Para roscados en materiales de hasta  $R_s \leq 850$  N/mm<sup>2</sup>. / Für Gewinde Stahl mit  $R_s \leq 850$  N/mm<sup>2</sup>, Stahlguss, alu Langspanend.

## 10291

### Maschi a macchina "lunghi", filettatura metrica ISO a passo grosso

Long machine taps, ISO metric coarse threads / Tarauds machine long filetage metric ISO

Machos de máquina largos, rosca metrica larga / Lange maschinen-gewindebohrer, metrisches-Regelgewinde

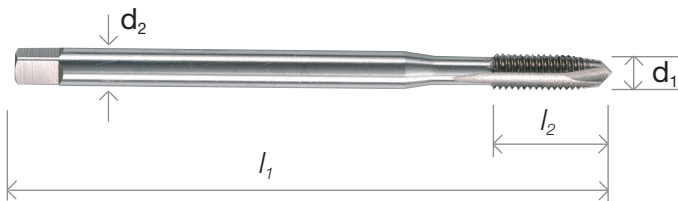
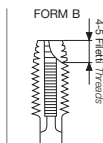
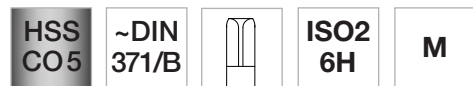

$d_1$	$l_1$	$l_2$	$d_2$	pcs	cod.	€ cad/each
<b>M 3</b> x 0,5	x 100	11	3,5	1	1029103100	21,580
<b>4</b> x 0,7	x 100	13	4,5	1	1029104100	21,580
<b>4</b> x 0,7	x 120	13	4,5	1	1029104120	22,925
<b>5</b> x 0,8	x 100	16	6	1	1029105100	22,925
<b>5</b> x 0,8	x 120	16	6	1	1029105120	24,685
<b>5</b> x 0,8	x 150	16	6	1	1029105150	26,361
<b>6</b> x 1	x 100	19	6	1	1029106100	22,925
<b>6</b> x 1	x 120	19	6	1	1029106120	24,685
<b>6</b> x 1	x 150	19	6	1	1029106150	26,361
<b>8</b> x 1,25	x 120	22	8	1	1029108120	28,131
<b>8</b> x 1,25	x 150	22	8	1	1029108150	32,582
<b>10</b> x 1,5	x 120	24	10	1	1029110120	32,582
<b>10</b> x 1,5	x 150	24	10	1	1029110150	39,630
<b>12</b> x 1,75	x 120	29	12	1	1029112120	37,778
<b>12</b> x 1,75	x 150	29	12	1	1029112150	45,437

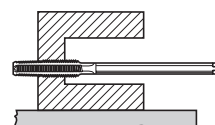
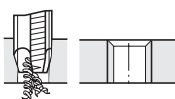

Per maschiature in acciai con  $R_s \leq 850 \text{ N/mm}^2$ , ghisa malleabile, metalli non ferrosi a truciolo lungo, acciai resistenti al calore, acciai refrattari, acciai inox.  
 For threading steel with  $R_s \leq 850 \text{ N/mm}^2$ , malleable cast iron, nonferrous metal with long chips, heat-resistant and refractory steel, stainless steel. / Pour tarauder acier avec  $R_s \leq 850 \text{ N/mm}^2$  fonte malléable, alliages légers, acier réfractaire et acier inoxydable. / Para atarrajar acero con  $R_s \leq 850 \text{ N/mm}^2$ , fundición, aleaciones ligeras, acero aleado y refractario, acero inoxidable. / Um in Stahl mit  $R_s \leq 850 \text{ N/mm}^2$ , Temperguss, Nichteisenmetalle, hitzbeständigem Stahl und rostfreierem Stahl Gewinde zu bohren

# 10292

## Maschi a macchina "lunghi", filettatura metrica ISO a passo grosso

Long machine taps, ISO metric coarse threads / Tarauds machine long filetage metric ISO

Machos de máquina largos, rosca metrica larga / Lange maschinen-gewindebohrer, metrisches-Regelgewinde

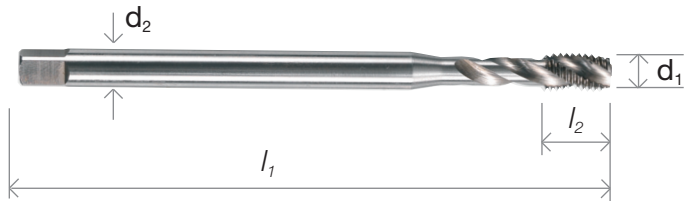

$d_1$	$l_1$	$l_2$	$d_2$	pcs	cod.	€ cad/each
<b>M 3</b> x 0,5	x 100	6	3,5	1	1029203100	25,523
<b>4</b> x 0,7	x 100	7	4,5	1	1029204100	25,523
<b>4</b> x 0,7	x 120	7	4,5	1	1029204120	26,361
<b>5</b> x 0,8	x 100	8	6	1	1029205100	27,293
<b>5</b> x 0,8	x 120	8	6	1	1029205120	29,052
<b>5</b> x 0,8	x 150	8	6	1	1029205150	31,661
<b>6</b> x 1	x 100	10	6	1	1029206100	27,293
<b>6</b> x 1	x 120	10	6	1	1029206120	29,052
<b>6</b> x 1	x 150	10	6	1	1029206150	31,661
<b>8</b> x 1,25	x 120	14	8	1	1029208120	33,420
<b>8</b> x 1,25	x 150	14	8	1	1029208150	36,939
<b>10</b> x 1,5	x 120	16	10	1	1029210120	38,709
<b>10</b> x 1,5	x 150	16	10	1	1029210150	44,919
<b>12</b> x 1,75	x 120	18	12	1	1029212120	40,365
<b>12</b> x 1,75	x 150	18	12	1	1029212150	48,128

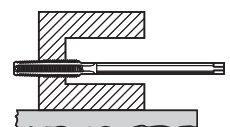
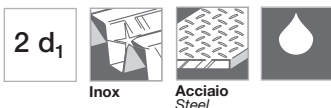
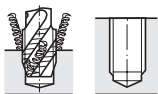

Per maschiature in acciai con  $R_s \leq 850 \text{ N/mm}^2$ , ghisa malleabile, metalli non ferrosi a truciolo lungo, acciai resistenti al calore, acciai refrattari, acciai inox.  
 For threading steel with  $R_s \leq 850 \text{ N/mm}^2$ , malleable cast iron, nonferrous metal with long chips, heat-resistant and refractory steel, stainless steel. / Pour tarauder  
 acier avec  $R_s \leq 850 \text{ N/mm}^2$  fonte malléable, alliages légers, acier réfractaire et acier inoxydable. / Para atarrajar acero con  $R_s \leq 850 \text{ N/mm}^2$ , fundición, aleaciones  
 ligeras, acero aleado y refractario, acero inoxidable. / Um in Stahl mit  $R_s \leq 850 \text{ N/mm}^2$ , Temperguss, Nichteisenmetalle, hitzbeständigem Stahl und rostfreierem Stahl  
 Gewinde zu bohren



## 10330

### Maschi a macchina con canalina di refrigerazione interna, filettatura metrica ISO a passo grosso

Machine taps with internal cooling system, ISO metric thread / Tarauds machine avec trous réfrigérants, filetage metric ISO

Machos de màquina con sistema de refrigeraci3n interno, rosca metrica larga / Maschinen-gewindebohrer mit Schmierloch, metrisches-Regelgewinde

**HSS CO5** **DIN 371/C** **ISO2 6H** **M**

40°

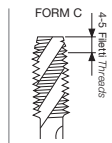

**Canalina di refrigerazione**  
Internal cooling system



	$d_1$	$l_2$	$l_1$	$d_2$	pcs	cod.	€ cad/each
<b>M 5</b>	x 0,8	8,5	70	6	1	1033005X08	93,150
<b>6</b>	x 1	11	80	6	1	1033006X1	93,150
<b>8</b>	x 1,25	14	90	8	1	1033008X125	93,150
<b>10</b>	x 1,5	16	100	10	1	1033010X15	132,480

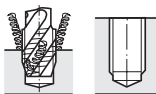

**3 d<sub>1</sub>**

**Inox** **Acciaio Steel**

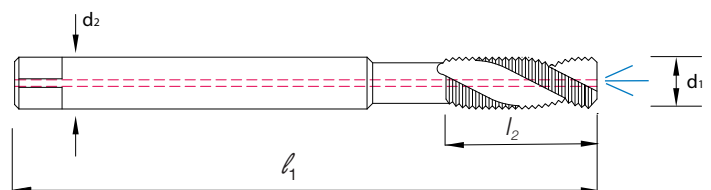

Per maschiature in acciai con  $R_s \leq 850 \text{ N/mm}^2$ , ghisa malleabile, metalli non ferrosi a truciolo lungo, acciai resistenti al calore, acciai refrattari, acciai inox.  
For threading steel with  $R_s \leq 850 \text{ N/mm}^2$ , malleable cast iron, nonferrous metal with long chips, heat-resistant and refractory steel, stainless steel. / Pour tarauder acier avec  $R_s \leq 850 \text{ N/mm}^2$  fonte malléable, alliages légers, acier réfractaire et acier inoxydable. / Para atarrajar acero con  $R_s \leq 850 \text{ N/mm}^2$ , fundici3n, aleaciones ligeras, acero aleado y refractario, acero inoxidable. / Um in Stahl mit  $R_s \leq 850 \text{ N/mm}^2$ , Temperguss, Nichteisenmetalle, hitzbeständigem Stahl und rostfreierem Stahl Gewinde zu bohren

# 10340

## Maschi a macchina con canalina di refrigerazione interna, filettatura metrica ISO a passo grosso

Machine taps with internal cooling system, ISO metric thread / Tarauds machine avec trous réfrigérants, filetage metric ISO

Machos de màquina con sistema de refrigeración interno, rosca metrica larga / Maschinen-gewindebohrer mit Schmierloch, metrisches-Regelgewinde

HM
DIN 371/C
6HX
M

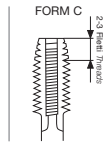

Canalina di refrigerazione  
Internal cooling system

**METALLO DURO/CARBIDE**

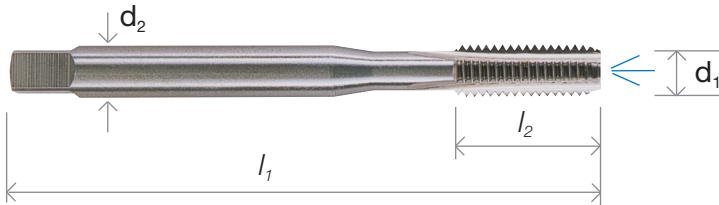

	$d_1$	$l_2$	$l_1$	$d_2$	pcs	cod.	€ cad/each
<b>M 3</b>	x 0,5	8	56	3,5	1	1034003X05	149,040
<b>4</b>	x 0,7	10	63	4,5	1	1034004X07	149,040
<b>5</b>	x 0,8	10	70	6	1	1034005X08	175,950
<b>6</b>	x 1	12	80	6	1	1034006X1	175,950
<b>8</b>	x 1,25	16	90	8	1	1034008X125	267,030
<b>10</b>	x 1,5	18	100	10	1	1034010X15	267,030

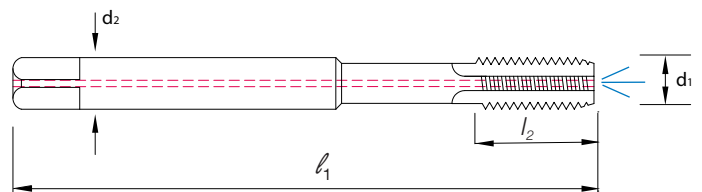
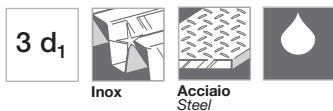
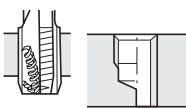

Altissimo rendimento nella maschiatura di acciai ad alta resistenza sino a  $R_s \leq 1300 \text{ N/mm}^2$ , quali acciai inox, acciai resistenti alla corrosione, acciai refrattari, acciai da bonifica alto legati trattati. Temperatura operativa sino a  $800^\circ$ . High performances in high strength steel with  $R_s \leq 1300 \text{ N/mm}^2$ , stainless steel, heat resistant steel, high alloy steel. / Haute rendement en taraudage des aciers alliés traités, acier inox, acier refractaire avec  $R_s \leq 1300 \text{ N/mm}^2$ . / Alto rendimento en taladro de acero de alta resistencia de hasta  $R_s \leq 1300 \text{ N/mm}^2$ , acero inox, acero aleado tratado, etc... / Breites anwendungsspektrum u.a. für gut Spanbare Stähle, rostfrei Stähle, Säurebeständigstähle und Vergütungsstähle bis  $1300 \text{ N/mm}^2$ .

## 10297

### Maschi a macchina con trattamento di rivestimento superficiale

Machine taps with coating treatment / Tarauds machine avec traitement de revetement superficiel

Machos de maquina con tratamiento de recubrimiento superficial / Maschinengewindebohrer mit Beschichtung

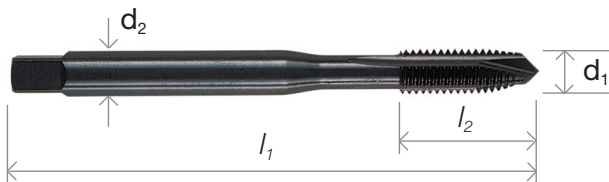
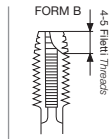
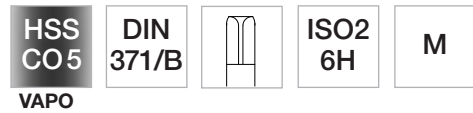

	d <sub>1</sub>	l <sub>2</sub>	l <sub>1</sub>	d <sub>2</sub>	pcs	cod.	€
							cad/each
<b>M</b>	3 x 0,5	11	56	3,5	1	1029703X05	16,125
	4 x 0,7	13	63	4,5	1	1029704X07	16,125
	5 x 0,8	16	70	6	1	1029705X08	17,026
	6 x 1	19	80	6	1	1029706X1	17,026
	8 x 1,25	22	90	8	1	1029708X125	20,131
	10 x 1,5	24	100	10	1	1029710X15	24,084



## 10298

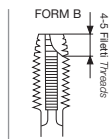
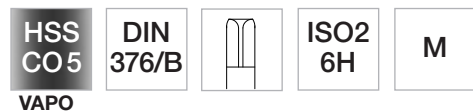

	d	l <sub>2</sub>	l <sub>1</sub>	d <sub>1</sub>	pcs	cod.	€
							cad/each
<b>M</b>	12 x 1,75	29	110	9	1	1029812X175	30,150
	14 x 2	30	110	11	1	1029814X2	40,903
	16 x 2	30	110	12	1	1029816X2	47,413
	18 x 2,5	34	125	14	1	1029818X25	65,484
	20 x 2,5	34	140	16	1	1029820X25	90,676

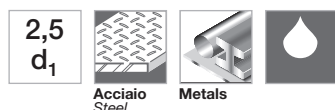

**Finitura:** Ossidazione in vapore di Fe<sub>3</sub>O<sub>4</sub> che aumenta la durezza superficiale e la resistenza a usura riducendo la tendenza all'incollamento dei trucioli.  
Finish: Steam Tempered of Fe<sub>3</sub>O<sub>4</sub>, increasing surface hardness and wear resistance.



7 pcs - M 3÷12

10345315

€ 147,767

Per acciai con R ≤ 900 N/mm<sup>2</sup>, materiali mediamente abrasivi, ghisa e metalli in genere. Suitable for steel with R ≤ 900 N/mm<sup>2</sup>, quite abrasive materials, cast iron, metals. Para los aceros con R ≤ 900 N/mm<sup>2</sup>, materiales mediamente abrasivos, fundición y todos los metales. / Pour les aciers avec R ≤ 900 N/mm<sup>2</sup>, matériaux modérément abrasifs, de la fonte et tous les métaux.

# 10299

## Maschi a macchina con trattamento di rivestimento superficiale

Machine taps with coating treatment / Tarauds machine avec traitement de revetement superficiel

Machos de maquina con tratamiento de recubrimiento superficial / Maschinengewindebohrer mit Beschichtung

HSS  
CO5

VAPO

DIN  
371/C

35°



ISO2  
6H

M

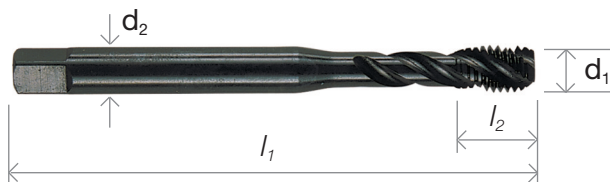
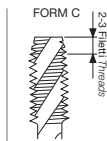

	d <sub>1</sub>	l <sub>2</sub>	l <sub>1</sub>	d <sub>2</sub>	pcs	cod.	€ cad/each
<b>M</b>	3 x 0,5	6	56	3,5	1	1029903X05	22,998
	4 x 0,7	7	63	4,5	1	1029904X07	22,998
	5 x 0,8	8	70	6	1	1029905X08	23,898
	6 x 1	10	80	6	1	1029906X1	23,898
	8 x 1,25	14	90	8	1	1029908X125	28,701
	10 x 1,5	16	100	10	1	1029910X15	33,493

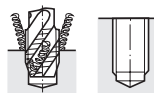

# 10300

HSS  
CO5

VAPO

DIN  
376/C

35°



ISO2  
6H

M

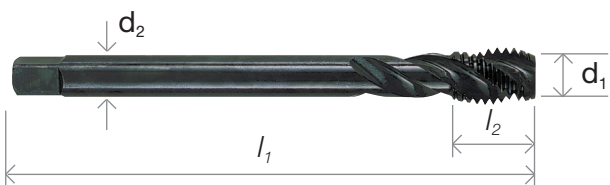
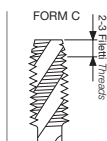

	d <sub>1</sub>	l <sub>2</sub>	l <sub>1</sub>	d <sub>2</sub>	pcs	cod.	€ cad/each
<b>M</b>	12 x 1,75	18	110	9	1	1030012X175	41,183
	14 x 2	20	110	11	1	1030014X2	52,682
	16 x 2	22	110	12	1	1030016X2	56,490
	18 x 2,5	25	125	14	1	1030018X25	80,388
	20 x 2,5	25	140	16	1	1030020X25	105,228

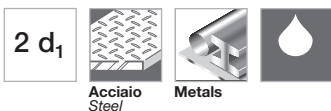
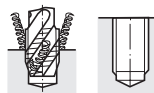

7 pcs - M 3÷12

10345316

€ 181,353

Per acciai con  $R \leq 900$  N/mm<sup>2</sup>, materiali mediamente abrasivi, ghisa e metalli in genere. Suitable for steel with  $R \leq 900$  N/mm<sup>2</sup>, quite abrasive materials, cast iron, metals. Para los aceros con  $R \leq 900$  N/mm<sup>2</sup>, materiales mediamente abrasivos, fundición y todos los metales. / Pour les aciers avec  $R \leq 900$  N/mm<sup>2</sup>, matériaux modérément abrasifs, de la fonte et tous les métaux.

## 10350

Maschi a macchina in HSS-CO rivestiti al TiN, fil. metrica ISO a passo grosso

HSS-CO TiN coated machine taps, metric thread / Tarauds machine HSS-CO avec revêtement TiN, fil. métrique

Machos de maquina HSS-CO con recubrimiento de titanio, rosca metrica / Maschinengewindebohrer mit TiN beschichtung für metrisches ISO Regelgewinde

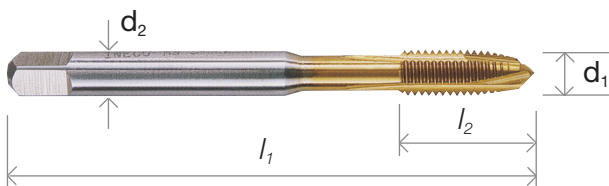
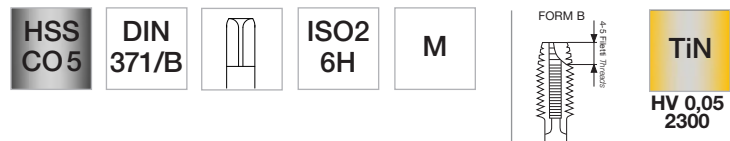

	d <sub>1</sub>	l <sub>2</sub>	l <sub>1</sub>	d <sub>2</sub>	pcs	cod.	€ cad/each
<b>M</b>	3 x 0,5	11	56	3,5	1	1035003X05	23,505
	4 x 0,7	13	63	4,5	1	1035004X07	21,042
	5 x 0,8	16	70	6	1	1035005X08	23,339
	6 x 1	19	80	6	1	1035006X1	24,260
	8 x 1,25	22	90	8	1	1035008X125	31,050
	10 x 1,5	24	100	10	1	1035010X15	33,638



## 10351

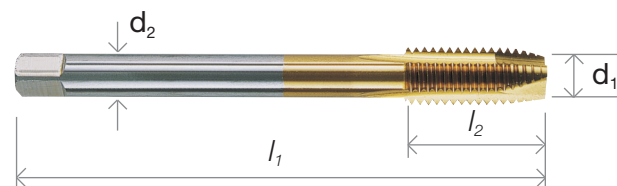

	d <sub>1</sub>	l <sub>2</sub>	l <sub>1</sub>	d <sub>2</sub>	pcs	cod.	€ cad/each
<b>M</b>	12 x 1,75	29	110	9	1	1035112X175	40,241
	14 x 2	30	110	11	1	1035114X2	51,170
	16 x 2	30	110	12	1	1035116X2	58,074
	18 x 2,5	34	125	14	1	1035118X25	70,949
	20 x 2,5	34	140	16	1	1035120X25	84,870
	22 x 2,5	34	140	18	1	1035122X25	92,912
	24 x 3	38	160	18	1	1035124X3	111,946

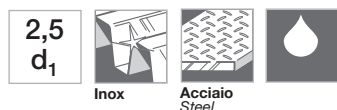

7 pcs - M 3÷12

10390300

€ 173,518

Alto rendimento nella filettatura in acciai ad elevata resistenza sino a R<sub>s</sub>1200 N/mm<sup>2</sup>, quali acciai da bonifica alto legati, acciai inox, acciai resistenti agli acidi, acciai refrattari. Temperatura max. di lavoro 550°. High performances in high strength steel R<sub>s</sub> 1200 N/mm<sup>2</sup>, stainless steel, acid resistant steel, high alloy construction steel. / Haute rendement en taraudage des aciers alliés traités, acier inox, acier refractaire avec R<sub>s</sub>1200 N/mm<sup>2</sup> / Alto rendimento en taladro de acero de alta resistencia de hasta R<sub>s</sub>1200 N/mm<sup>2</sup>, acero inox, acero tratado, etc... / Breites anwendungsspektrum u.a. für gut Spanbare Stähle, rostfrei Stähle, Säurebeständigestähle und Vergütungsstähle bis 1200 N/mm<sup>2</sup>.

# 10354

## Maschi a macchina in HSS-CO rivestiti al TiN, fil. metrica ISO a passo grosso

HSS-CO TiN coated machine taps, metric thread / Tarauds machine HSS-CO avec revêtement TiN, fil. métrique

Machos de maquina HSS-CO con recubrimiento de titanio, rosca metrica / Maschinengewindebohrer mit TiN beschichtung für metrisches ISO Regelgewinde

HSS  
CO 5

DIN  
371/C

35°



ISO2  
6H

M

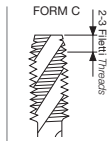

TiN

HV 0,05  
2300

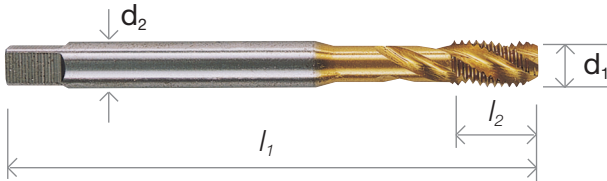

	d <sub>1</sub>	l <sub>2</sub>	l <sub>1</sub>	d <sub>2</sub>	pcs	cod.	€ cad/each
<b>M</b>	3 x 0,5	6	56	3,5	1	1035403X05	27,821
	4 x 0,7	7	63	4,5	1	1035404X07	27,821
	5 x 0,8	8	70	6	1	1035405X08	26,496
	6 x 1	10	80	6	1	1035406X1	27,396
	8 x 1,25	14	90	8	1	1035408X125	35,666
	10 x 1,5	16	100	10	1	1035410X15	39,692

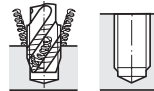

# 10355

HSS  
CO 5

DIN  
376/C

35°



ISO2  
6H

M

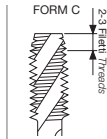

TiN

HV 0,05  
2300

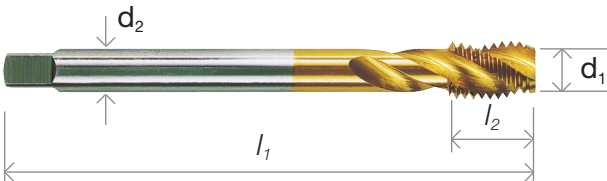

	d <sub>1</sub>	l <sub>2</sub>	l <sub>1</sub>	d <sub>2</sub>	pcs	cod.	€ cad/each
<b>M</b>	12 x 1,75	18	110	9	1	1035512X175	48,604
	14 x 2	20	110	11	1	1035514X2	60,413
	16 x 2	22	110	12	1	1035516X2	68,486
	18 x 2,5	25	125	14	1	1035518X25	83,162
	20 x 2,5	25	140	16	1	1035520X25	98,739
	22 x 2,5	25	140	18	1	1035522X25	114,181
	24 x 3	30	160	18	1	1035524X3	127,616

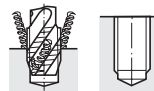

7 pcs - M 3÷12

10390305

€ 201,504

2 d<sub>1</sub>



Inox

Acciaio  
Steel

Alto rendimento nella filettatura in acciai ad elevata resistenza sino a R<sub>s</sub>≤1200 N/mm<sup>2</sup>, quali acciai da bonifica alto legati, acciai inox, acciai resistenti agli acidi, acciai refrattari. Temperatura max. di lavoro 550°. High performances in high strength steel R<sub>s</sub>≤ 1200 N/mm<sup>2</sup>, stainless steel, acid resistant steel, high alloy construction steel. / Haute rendement en taraudage des aciers alliés traités, acier inox, acier refractaire avec R<sub>s</sub>≤1200 N/mm<sup>2</sup> / Alto rendimento en taladro de acero de alta resistencia de hasta R<sub>s</sub>≤1200 N/mm<sup>2</sup>, acero inox, acero tratado, etc... / Breites anwendungsspektrum u.a. für gut Spanbare Stähle, rostfrei Stähle, Säurebeständigestähle und Vergütungsstähle bis 1200 N/mm<sup>2</sup>.

## 10400

### Maschi a macchina in HSS-CO rivestiti al TiAIN, fil. metrica passo grosso

HSS-CO TiAIN coated machine taps / Tarauds machine HSS-CO avec revêtement TiAIN, fil. métrique

Machos de maquina HSS-CO con recubrimiento TiAIN, rosca metrica / Maschinengewindebohrer mit TiAIN beschichtung für metrisches ISO Regelgewinde

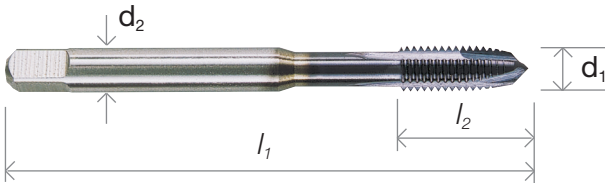
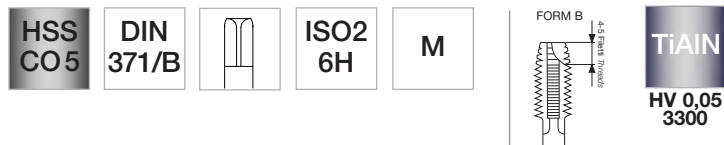

	d <sub>1</sub>	l <sub>2</sub>	l <sub>1</sub>	d <sub>2</sub>	pcs	cod.	€ cad/each
<b>M</b>	3 x 0,5	11	56	3,5	1	1040003X05	25,751
	4 x 0,7	13	63	4,5	1	1040004X07	25,751
	5 x 0,8	16	70	6	1	1040005X08	25,751
	6 x 1	19	80	6	1	1040006X1	27,428
	8 x 1,25	22	90	8	1	1040008X125	32,468
	10 x 1,5	24	100	10	1	1040010X15	35,180



## 10401

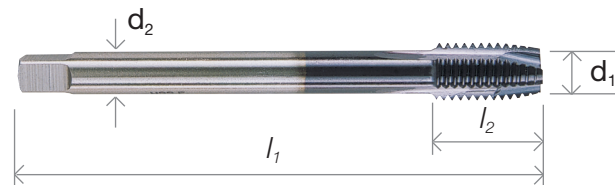

	d <sub>1</sub>	l <sub>2</sub>	l <sub>1</sub>	d <sub>2</sub>	pcs	cod.	€ cad/each
<b>M</b>	12 x 1,75	29	110	9	1	1040112X175	46,316
	14 x 2	30	110	11	1	1040114X2	59,161
	16 x 2	30	110	12	1	1040116X2	66,623
	18 x 2,5	34	125	14	1	1040118X25	79,488
	20 x 2,5	34	140	16	1	1040120X25	97,394
	22 x 2,5	34	140	18	1	1040122X25	109,710
	24 x 3	38	160	18	1	1040124X3	127,616

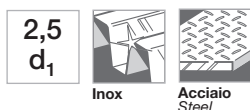

7 pcs - M 3÷12

10450300

€ 199,269

Altissimo rendimento nella maschiatura di acciai ad alta resistenza sino R<sub>s</sub> 1300 N/mm<sup>2</sup>, quali acciai inox, acciai resistenti alla corrosione, acciai refrattari, acciai da bonifica alto legati trattati. Temperatura operativa sino a 800°. High performances in high strength steel with R<sub>s</sub> 1300 N/mm<sup>2</sup>, stainless steel, heat resistant steel, high alloy steel. / Haute rendement en taraudage des aciers alliés traités, acier inox, acier refractaire avec R<sub>s</sub> 1300 N/mm<sup>2</sup>. / Alto rendimento en taladro de acero de alta resistencia de hasta R<sub>s</sub> 1300 N/mm<sup>2</sup>, acero inox, acero aleado tratado, etc... / Breites Anwendungsspektrum u.a. für gut Spanbare Stähle, rostfrei Stähle, Säurebeständigstähle und Vergütungsstähle bis 1300 N/mm<sup>2</sup>.

# 10404

## Maschi a macchina in HSS-CO rivestiti al TiAlN, fil. metrica passo grosso

HSS-CO TiAlN coated machine taps / Tarauds machine HSS-CO avec revêtement TiAlN, fil. métrique

Machos de maquina HSS-CO con recubrimiento TiAlN, rosca metrica / Maschinengewindebohrer mit TiAlN beschichtung für metrisches ISO Regelgewinde

HSS  
CO 5

DIN  
371/C

35°



ISO2  
6H

M

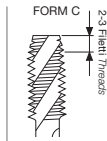

TiAlN

HV 0,05  
3300

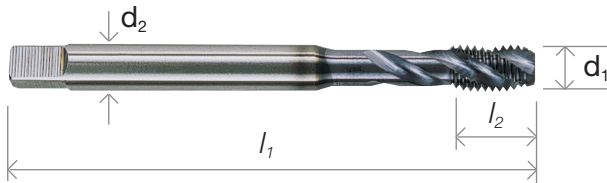

	d <sub>1</sub>	l <sub>2</sub>	l <sub>1</sub>	d <sub>2</sub>	pcs	cod.	€ cad/each
<b>M</b>	3 x 0,5	6	56	3,5	1	1040403X05	30,781
	4 x 0,7	7	63	4,5	1	1040404X07	30,781
	5 x 0,8	8	70	6	1	1040405X08	32,013
	6 x 1	10	80	6	1	1040406X1	32,582
	8 x 1,25	14	90	8	1	1040408X125	40,303
	10 x 1,5	16	100	10	1	1040410X15	44,163

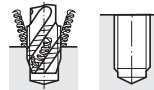

# 10405

HSS  
CO 5

DIN  
376/C

35°



ISO2  
6H

M

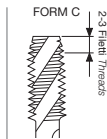

TiAlN

HV 0,05  
3300

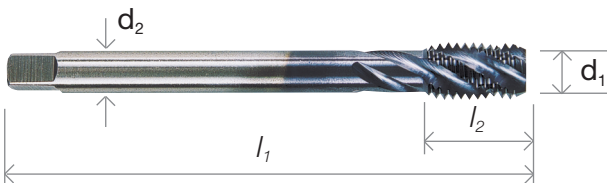

	d <sub>1</sub>	l <sub>2</sub>	l <sub>1</sub>	d <sub>2</sub>	pcs	cod.	€ cad/each
<b>M</b>	12 x 1,75	18	110	9	1	1040512X175	55,497
	14 x 2	20	110	11	1	1040514X2	69,511
	16 x 2	22	110	12	1	1040516X2	78,318
	18 x 2,5	25	125	14	1	1040518X25	93,088
	20 x 2,5	25	140	16	1	1040520X25	113,063
	22 x 2,5	25	140	18	1	1040522X25	127,616
	24 x 3	30	160	18	1	1040524X3	146,649

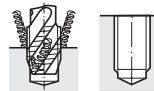

7 pcs - M 3÷12

10450305

€ 222,773

Altissimo rendimento nella maschiatura di acciai ad alta resistenza sino  $R_s \leq 1300 \text{ N/mm}^2$ , quali acciai inox, acciai resistenti alla corrosione, acciai refrattari, acciai da bonifica alto legati trattati. Temperatura operativa sino a  $800^\circ$ . High performances in high strength steel with  $R_s \leq 1300 \text{ N/mm}^2$ , stainless steel, heat resistant steel, high alloy steel. / Haute rendement en taraudage des aciers alliés traités, acier inox, acier refractaire avec  $R_s \leq 1300 \text{ N/mm}^2$ . / Alto rendimento en taladro de acero de alta resistencia de hasta  $R_s \leq 1300 \text{ N/mm}^2$ , acero inox, acero aleado tratado, etc... / Breites anwendungsspektrum u.a. für gut Spanbare Stähle, rostfrei Stähle, Säurebeständiggestähle und Vergütungsstähle bis  $1300 \text{ N/mm}^2$ .



## 10259

### Maschi a macchina, scan. diritte, imb. corretto, filettatura metrica ISO a passo fine

Machine taps, metric ISO fine thread / Tarauds machine, filetage métrique pas fin

Machos de maquina, rosca metrica fina / Maschinengewindebohrer für metrisches ISO fein-Gewinde

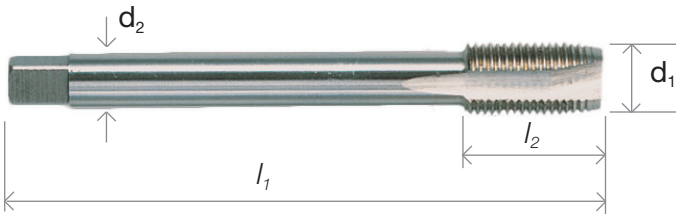
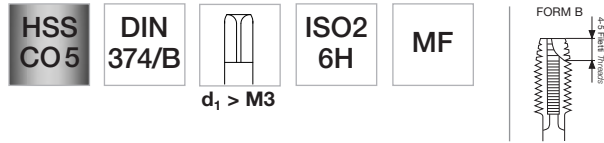

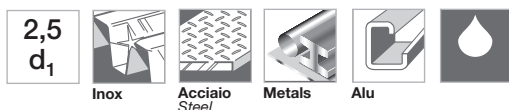
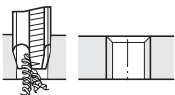

d <sub>1</sub>	l <sub>2</sub>	l <sub>1</sub>	d <sub>2</sub>		cod.	€ cad/each
M 3 x 0,35	9	56	2,2	1	1025903X035	29,084
4 x 0,35	10	63	2,8	1	1025904X035	29,084
4 x 0,5	10	63	2,8	1	1025904X05	25,368
5 x 0,5	12	70	3,5	1	1025905X05	25,368
5 x 0,75	12	70	3,5	1	1025905X075	29,084
6 x 0,5	14	80	4,5	1	1025906X05	26,082
6 x 0,75	14	80	4,5	1	1025906X075	26,082
7 x 0,75	14	80	5,5	1	1025907X075	35,883
8 x 0,5	19	80	6	1	1025908X05	41,400
8 x 0,75	19	80	6	1	1025908X075	33,638
8 x 1	22	90	6	1	1025908X1	29,446
9 x 0,75	19	80	7	1	1025909X075	39,278
9 x 1	22	90	7	1	1025909X1	35,883
10 x 0,75	20	90	7	1	1025910X075	34,300
10 x 1	20	90	7	1	1025910X1	34,300
10 x 1,25	24	100	7	1	1025910X125	34,300
11 x 1	20	90	8	1	1025911X1	48,593
11 x 1,25	22	90	8	1	1025911X125	48,593
12 x 0,75	22	100	9	1	1025912X075	48,593
12 x 1	22	100	9	1	1025912X1	40,023
12 x 1,25	22	100	9	1	1025912X125	40,023
12 x 1,5	22	100	9	1	1025912X15	40,023
13 x 1	22	100	11	1	1025913X1	56,904
13 x 1,5	22	100	11	1	1025913X15	56,904
14 x 0,75	22	100	11	1	1025914X075	56,904
14 x 1	22	100	11	1	1025914X1	56,904

d <sub>1</sub>	l <sub>2</sub>	l <sub>1</sub>	d <sub>2</sub>		cod.	€ cad/each
14 x 1,25	22	100	11	1	1025914X125	56,904
14 x 1,5	22	100	11	1	1025914X15	56,904
15 x 1	22	100	12	1	1025915X1	56,904
15 x 1,5	22	100	12	1	1025915X15	56,904
16 x 1	22	100	12	1	1025916X1	56,904
16 x 1,25	22	100	12	1	1025916X125	56,904
16 x 1,5	22	100	12	1	1025916X15	56,904
18 x 1	25	110	14	1	1025918X1	68,476
18 x 1,25	25	110	14	1	1025918X125	68,476
18 x 1,5	25	110	14	1	1025918X15	68,476
18 x 2	34	125	14	1	1025918X2	68,476
20 x 1	25	125	16	1	1025920X1	73,040
20 x 1,25	25	125	16	1	1025920X125	73,040
20 x 1,5	25	125	16	1	1025920X15	73,040
20 x 2	34	140	16	1	1025920X2	73,040
21 x 1,5	25	125	16	1	1025921X15	98,915
22 x 1	25	125	18	1	1025922X1	98,915
22 x 1,25	25	125	18	1	1025922X125	98,915
22 x 1,5	25	125	18	1	1025922X15	98,915
22 x 2	34	140	18	1	1025922X2	98,915
23 x 1,5	25	125	18	1	1025923X15	132,097
24 x 1	28	140	18	1	1025924X1	114,181
24 x 1,25	28	140	18	1	1025924X125	114,181
24 x 1,5	28	140	18	1	1025924X15	114,181
24 x 2	28	140	18	1	1025924X2	114,181
25 x 1	28	140	18	1	1025925X1	132,097



Per fori passanti in acciai con R<sub>s</sub> 850 N/mm<sup>2</sup>, ghisa, metalli non ferrosi a truciolo lungo. For through holes in steel with R<sub>s</sub> 850 N/mm<sup>2</sup>, cast iron, non ferrous metals with long chip. / Pour trous débouchants en acier avec R<sub>s</sub> 850 N/mm<sup>2</sup>, fonte, alliages légers. / Para orificios pasantes en materiales de hasta R<sub>s</sub> 850 N/mm<sup>2</sup>. / Für durchgangsloch in Stahl mit R<sub>s</sub> 850 N/mm<sup>2</sup>, Stahlguss, alu langspanend.

d <sub>1</sub>	l <sub>2</sub>	l <sub>1</sub>	d <sub>2</sub>		cod.	€ cad/each
25 x 1,5	28	140	18	1	1025925X15	132,097
25 x 2	28	140	18	1	1025925X2	132,097
26 x 1	28	140	18	1	1025926X1	130,979
26 x 1,5	28	140	18	1	1025926X15	130,979
26 x 2	28	140	18	1	1025926X2	130,979
27 x 1	28	140	20	1	1025927X1	141,050
27 x 1,5	28	140	20	1	1025927X15	141,050
27 x 2	28	140	20	1	1025927X2	141,050
28 x 1	28	140	20	1	1025928X1	141,050
28 x 1,5	28	140	20	1	1025928X15	141,050
28 x 2	28	140	20	1	1025928X2	141,050
29 x 1,5	28	150	22	1	1025929X15	190,305
30 x 1	28	150	22	1	1025930X1	163,437
30 x 1,5	28	150	22	1	1025930X15	163,437
30 x 2	28	150	22	1	1025930X2	163,437
30 x 2,5	45	180	22	1	1025930X25	182,472
30 x 3	45	180	22	1	1025930X3	182,472
32 x 1,5	28	150	22	1	1025932X15	204,858
32 x 2	28	150	22	1	1025932X2	204,858
32 x 3	50	180	22	1	1025932X3	204,858
33 x 1,5	30	160	25	1	1025933X15	228,373
33 x 2	30	160	25	1	1025933X2	228,373
33 x 3	50	180	25	1	1025933X3	228,373
34 x 1,5	30	170	28	1	1025934X15	232,844
34 x 2	30	170	28	1	1025934X2	232,844
35 x 1,5	30	170	28	1	1025935X15	242,925

d <sub>1</sub>	l <sub>2</sub>	l <sub>1</sub>	d <sub>2</sub>		cod.	€ cad/each
36 x 1,5	30	170	28	1	1025936X15	242,925
36 x 2	30	170	28	1	1025936X2	242,925
36 x 3	56	200	28	1	1025936X3	242,925
38 x 1,5	30	170	28	1	1025938X15	259,713
39 x 1,5	30	170	32	1	1025939X15	259,713
39 x 2	30	170	32	1	1025939X2	259,713
39 x 3	60	200	32	1	1025939X3	259,713
40 x 1,5	30	170	32	1	1025940X15	280,982
40 x 2	30	170	32	1	1025940X2	280,982
40 x 3	60	200	32	1	1025940X3	280,982
42 x 1,5	30	170	32	1	1025942X15	334,719
42 x 2	30	170	32	1	1025942X2	334,719
42 x 3	60	200	32	1	1025942X3	334,719
45 x 1,5	32	180	36	1	1025945X15	372,776
45 x 2	32	180	36	1	1025945X2	372,776
45 x 3	50	200	36	1	1025945X3	372,776
48 x 1,5	32	190	36	1	1025948X15	444,429
48 x 2	32	190	36	1	1025948X2	444,429
48 x 3	50	225	36	1	1025948X3	444,429
50 x 1,5	32	190	36	1	1025950X15	523,907
50 x 2	32	190	36	1	1025950X2	523,907
50 x 3	50	225	36	1	1025950X3	523,907
52 x 1,5	32	190	40	1	1025952X15	570,927
52 x 2	32	190	40	1	1025952X2	570,927
52 x 3	50	225	40	1	1025952X3	570,927
63 x 1,5	50	275	50	1	1025963X15	1006,393

## 10260

### Maschi a macchina, scan. elicoidali 35°, fil. metrica ISO a passo fine

Machine taps, 35° spiral flute, metric fine thread / Tarauds machine, goujournes 35°, filetage métrique fin

Machos de maquina, canal helicoidal 35°, rosca metrica fina / Maschinen-gewindebohrer, 35° rechtsspirale, für metrisches ISO Feingewinde

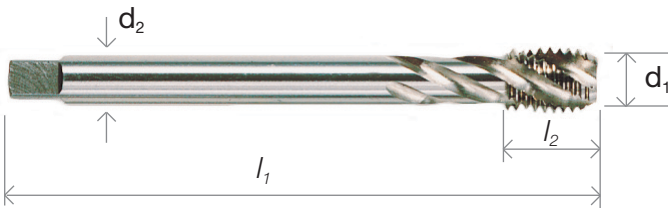
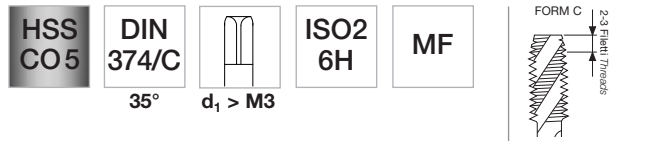

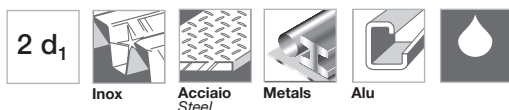
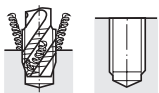

$d_1$	$l_2$	$l_1$	$d_2$		cod.	€ cad/each
M3 x 0,35	9	56	2,2	1	1026003X035	31,050
4 x 0,35	10	63	2,8	1	1026004X035	33,120
4 x 0,5	10	63	2,8	1	1026004X05	30,150
5 x 0,5	12	70	3,5	1	1026005X05	33,120
5 x 0,75	12	70	3,5	1	1026005X075	33,120
6 x 0,5	14	80	4,5	1	1026006X05	33,120
6 x 0,75	14	80	4,5	1	1026006X075	33,120
7 x 0,75	14	80	5,5	1	1026007X075	33,120
8 x 0,5	19	80	6	1	1026008X05	40,365
8 x 0,75	19	80	6	1	1026008X075	30,015
8 x 1	22	90	6	1	1026008X1	35,190
9 x 0,75	19	80	7	1	1026009X075	51,305
9 x 1	22	90	7	1	1026009X1	39,330
10 x 0,75	20	90	7	1	1026010X075	46,575
10 x 1	20	90	7	1	1026010X1	39,330
10 x 1,25	24	100	7	1	1026010X125	40,883
11 x 1	20	90	8	1	1026011X1	45,437
11 x 1,25	22	90	8	1	1026011X125	45,437
12 x 0,75	22	100	9	1	1026012X075	45,437
12 x 1	22	100	9	1	1026012X1	45,437
12 x 1,25	22	100	9	1	1026012X125	45,437
12 x 1,5	22	100	9	1	1026012X15	45,437
13 x 1	22	100	11	1	1026013X1	55,528
13 x 1,5	22	100	11	1	1026013X15	55,528
14 x 0,75	22	100	11	1	1026014X075	55,528
14 x 1	22	100	11	1	1026014X1	55,528

$d_1$	$l_2$	$l_1$	$d_2$		cod.	€ cad/each
14 x 1,25	22	100	11	1	1026014X125	55,528
14 x 1,5	22	100	11	1	1026014X15	55,528
15 x 1	22	100	12	1	1026015X1	64,522
15 x 1,5	22	100	12	1	1026015X15	64,522
16 x 1	22	100	12	1	1026016X1	64,522
16 x 1,25	22	100	12	1	1026016X125	64,522
16 x 1,5	22	100	12	1	1026016X15	64,522
18 x 1	25	110	14	1	1026018X1	79,198
18 x 1,25	25	110	14	1	1026018X125	79,198
18 x 1,5	25	110	14	1	1026018X15	79,198
18 x 2	34	125	14	1	1026018X2	79,198
20 x 1	25	125	16	1	1026020X1	88,079
20 x 1,25	25	125	16	1	1026020X125	88,079
20 x 1,5	25	125	16	1	1026020X15	88,079
20 x 2	34	140	16	1	1026020X2	88,079
21 x 1,5	25	125	16	1	1026021X15	88,079
22 x 1	25	125	18	1	1026022X1	111,780
22 x 1,25	25	125	18	1	1026022X125	111,780
22 x 1,5	25	125	18	1	1026022X15	106,543
22 x 2	34	140	18	1	1026022X2	106,543
23 x 1,5	25	125	18	1	1026023X15	129,075
24 x 1	28	140	18	1	1026024X1	129,075
24 x 1,25	28	140	18	1	1026024X125	129,075
24 x 1,5	28	140	18	1	1026024X15	129,075
24 x 2	28	140	18	1	1026024X2	129,075
25 x 1	28	140	18	1	1026025X1	129,075



Per fori ciechi in acciai con  $R_s \leq 850 \text{ N/mm}^2$ , ghisa malleabile, metalli non ferrosi a truciolo lungo, acciai resistenti al calore, acciai. For blind holes in steel with  $R_s \leq 850 \text{ N/mm}^2$ , malleable cast iron, non ferrous metals with long chips, stainless steel, heat resistant steel. / Pour trous borgnes en acier avec  $R_s \leq 850 \text{ N/mm}^2$ , fonte, alliages légers, acier inoxydable. / Para orificios ciegos en acero de hasta  $R_s \leq 850 \text{ N/mm}^2$ , aleaciones ligeras, fundicion, acero aleado y acero inox. / Für grundloch in Stahl mit  $R_s \leq 850 \text{ N/mm}^2$ , Stahlguss, alu langspanend, korrosions beständige Stähle (V 2A - V4A) etc.

d <sub>1</sub>	l <sub>2</sub>	l <sub>1</sub>	d <sub>2</sub>		cod.	€ cad/each
25 x 1,5	28	140	18	1	1026025X15	129,075
25 x 2	28	140	18	1	1026025X2	129,075
26 x 1	28	140	18	1	1026026X1	136,620
26 x 1,5	28	140	18	1	1026026X15	136,620
26 x 2	28	140	18	1	1026026X2	142,830
27 x 1	28	140	20	1	1026027X1	155,602
27 x 1,5	28	140	20	1	1026027X15	155,602
27 x 2	28	140	20	1	1026027X2	155,602
28 x 1	28	140	20	1	1026028X1	155,602
28 x 1,5	28	140	20	1	1026028X15	155,602
28 x 2	28	140	20	1	1026028X2	155,602
29 x 1,5	28	150	22	1	1026029X15	176,871
30 x 1	28	150	22	1	1026030X1	176,871
30 x 1,5	28	150	22	1	1026030X15	176,871
30 x 2	28	150	22	1	1026030X2	176,871
30 x 2,5	45	180	22	1	1026030X25	176,871
30 x 3	45	180	22	1	1026030X3	176,871
32 x 1,5	28	150	22	1	1026032X15	220,538
32 x 2	28	150	22	1	1026032X2	220,538
32 x 3	50	180	22	1	1026032X3	220,538
33 x 1,5	30	160	25	1	1026033X15	220,538
33 x 2	30	160	25	1	1026033X2	220,538
33 x 3	50	180	25	1	1026033X3	220,538
34 x 1,5	30	170	28	1	1026034X15	220,538
34 x 2	30	170	28	1	1026034X2	220,538
35 x 1,5	30	170	28	1	1026035X15	220,538

d <sub>1</sub>	l <sub>2</sub>	l <sub>1</sub>	d <sub>2</sub>		cod.	€ cad/each
36 x 1,5	30	170	28	1	1026036X15	276,511
36 x 2	30	170	28	1	1026036X2	276,511
36 x 3	56	200	28	1	1026036X3	276,511
38 x 1,5	30	170	28	1	1026038X15	291,063
39 x 1,5	30	170	32	1	1026039X15	291,063
39 x 2	30	170	32	1	1026039X2	291,063
39 x 3	60	200	32	1	1026039X3	291,063
40 x 1,5	30	170	32	1	1026040X15	316,803
40 x 2	30	170	32	1	1026040X2	316,803
40 x 3	60	200	32	1	1026040X3	316,803
42 x 1,5	30	170	32	1	1026042X15	358,224
42 x 2	30	170	32	1	1026042X2	358,224
42 x 3	60	200	32	1	1026042X3	358,224
45 x 1,5	32	180	36	1	1026045X15	419,796
45 x 2	32	180	36	1	1026045X2	419,796
45 x 3	50	200	36	1	1026045X3	419,796
48 x 1,5	32	190	36	1	1026048X15	498,156
48 x 2	32	190	36	1	1026048X2	498,156
48 x 3	50	225	36	1	1026048X3	498,156
50 x 1,5	32	190	36	1	1026050X15	582,115
50 x 2	32	190	36	1	1026050X2	582,115
50 x 3	50	225	36	1	1026050X3	582,115
52 x 1,5	32	190	40	1	1026052X15	639,206
52 x 2	32	190	40	1	1026052X2	639,206
52 x 3	50	225	40	1	1026052X3	639,206
63 x 1,5	40	275	50	1	1026063X15	1104,904

## 10252

Maschi a macchina, scanalature diritte, imbocco "C", fil. metrica ISO a passo fine.

Machine taps, "C" chamfer form, metric fine thread / Tarauds machine, entrée "C", filetage métrique fin

Machos de maquina, entrada "C", rosca metrica fina / Maschinengewindebohrer für metrisches ISO-fein-Gewinde

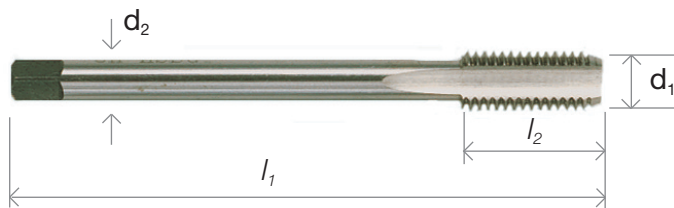
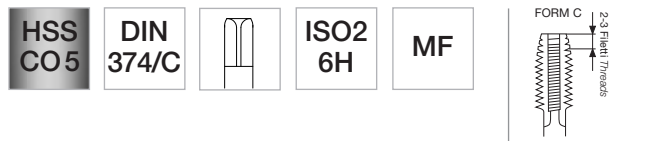

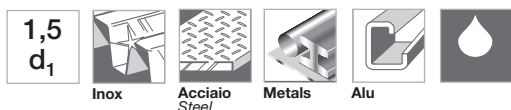
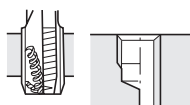

d <sub>1</sub>	l <sub>2</sub>	l <sub>1</sub>	d <sub>2</sub>		cod.	€ cad/each
M4 x 0,35	10	63	2,8	1	x1025204X035	21,114
5 x 0,5	12	70	3,5	1	1025205X05	21,114
6 x 0,75	14	80	4,5	1	1025206X075	21,114
8 x 0,75	19	80	6,0	1	1025208X075	24,436
8 x 1	22	90	6,0	1	1025208X1	24,436
10 x 1	20	90	7,0	1	1025210X1	28,090
10 x 1,25	24	100	7,0	1	1025210X125	28,090
12 x 1	22	100	9,0	1	1025212X1	29,301
12 x 1,25	22	100	9,0	1	1025212X125	29,301
12 x 1,5	22	100	9,0	1	1025212X15	29,301
14 x 1	22	100	11,0	1	1025214X1	33,586
14 x 1,25	22	100	11,0	1	1025214X125	33,586
14 x 1,5	22	100	11,0	1	1025214X15	33,586

d <sub>1</sub>	l <sub>2</sub>	l <sub>1</sub>	d <sub>2</sub>		cod.	€ cad/each
16 x 1	22	100	12,0	1	1025216X1	38,947
16 x 1,5	22	100	12,0	1	1025216X15	38,947
18 x 1	25	110	14,0	1	1025218X1	48,024
18 x 1,5	25	110	14,0	1	1025218X15	48,024
18 x 2	34	125	14,0	1	1025218X2	48,024
20 x 1	25	125	16,0	1	1025220X1	53,458
20 x 1,25	25	125	16,0	1	1025220X125	53,458
20 x 1,5	25	125	16,0	1	1025220X15	53,458
20 x 2	34	140	16,0	1	1025220X2	53,458
22 x 1	25	125	18,0	1	1025222X1	62,162
22 x 1,5	25	125	18,0	1	1025222X15	62,162
22 x 2	34	140	18,0	1	1025222X2	62,162
24 x 1	28	140	18,0	1	1025224X1	70,753



Per fori ciechi e passanti in acciai e ghisa con R<sub>s</sub> 850 N/mm<sup>2</sup>. For blind and through holes in steel with R<sub>s</sub> 850 N/mm<sup>2</sup> / Pour trous débouchants et borgnes en acier avec R<sub>s</sub>850 N/mm<sup>2</sup> / Para orificios pasantes y ciegos in acero de hasta R<sub>s</sub> 850 N/mm<sup>2</sup> / Für grund- und durchgangsloch in Stahl, Stahlguss mit R<sub>s</sub> 850 N/mm<sup>2</sup>.

d <sub>1</sub>	l <sub>2</sub>	l <sub>1</sub>	d <sub>2</sub>		cod.	€ cad/each
24 x 1,5	28	140	18,0	1	1025224X15	70,753
24 x 2	28	140	18,0	1	1025224X2	70,753
25 x 1	28	140	18,0	1	1025225X1	95,158
26 x 1,5	28	140	18,0	1	1025226X15	85,739
27 x 1,5	28	140	20,0	1	1025227X15	95,758
27 x 2	28	140	20,0	1	1025227X2	95,758
28 x 1,5	28	140	20,0	1	1025228X15	95,758
30 x 1,5	28	150	22,0	1	1025230X15	106,833
30 x 2	28	150	22,0	1	1025230X2	106,833
32 x 1,5	28	150	22,0	1	1025232X15	120,898
32 x 2	28	150	22,0	1	1025232X2	120,898
33 x 2	30	160	25,0	1	1025233X2	135,450
35 x 1,5	30	170	28,0	1	1025235X15	145,531

d <sub>1</sub>	l <sub>2</sub>	l <sub>1</sub>	d <sub>2</sub>		cod.	€ cad/each
36 x 1,5	30	170	28,0	1	1025236X15	156,720
36 x 2	30	170	28,0	1	1025236X2	156,720
38 x 1,5	30	170	28,0	1	1025238X15	167,918
40 x 1,5	30	170	32,0	1	1025240X15	195,905
42 x 1,5	30	170	32,0	1	1025242X15	195,905
45 x 1,5	32	180	36,0	1	1025245X15	231,726
48 x 1,5	32	190	36,0	1	1025248X15	264,194
50 x 1,5	32	190	36,0	1	1025250X15	349,271
52 x 1,5	32	190	40,0	1	1025252X15	349,271

## 10280

### Maschi a macchina a rullare, fil. metrica ISO a passo grosso

Cold forming machine taps, ISO thread/ Tarauds à refouler

Machos de maquina laminacion / Maschinengewindefurcher

<b>HSS CO5</b>	<b>DIN 371</b>	<b>DIN 376</b>		<b>ISO2X 6HX</b>	<b>M</b>	<b>Speciale per lamiere Special for metal sheets</b>
	<b>M3±10</b>	<b>M12±16</b>				

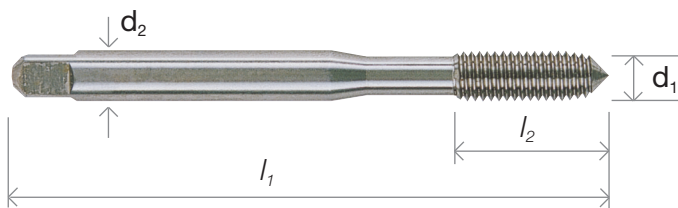
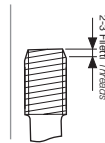

d <sub>1</sub>	l <sub>2</sub>	l <sub>1</sub>	d <sub>2</sub>	preforo drill	pcs	cod.	€ cad/each
<b>DIN 371</b>							
<b>M 3 x 0,5</b>	11	56	3,5	2,80	1	1028003X05	25,295
<b>4 x 0,7</b>	13	63	4,5	3,70	1	1028004X07	28,504
<b>5 x 0,8</b>	16	70	6,0	4,65	1	1028005X08	30,822
<b>6 x 1</b>	19	80	6,0	5,55	1	1028006X1	30,822
<b>8 x 1,25</b>	22	90	8,0	7,45	1	1028008X125	37,239
<b>10 x 1,5</b>	24	100	10	9,30	1	1028010X15	44,609
<b>DIN 376</b>							
<b>M 12 x 1,75</b>	29	110	9,0	11,20	1	1028012X175	55,300
<b>14 x 2</b>	30	110	11	13,0	1	1028014X2	77,780
<b>16 x 2</b>	32	110	12	15,1	1	1028016X2	97,952



<b>2,5 d<sub>1</sub></b>						<b>Lubrorefrigerazione con olio o grafite raccomandata</b> Recommended oil or graphite cooling
	<b>Inox</b>	<b>Acciaio Steel</b>	<b>Metals</b>	<b>Alu</b>		

Per acciai con R ≤ 900 N/mm<sup>2</sup>, materiali mediamente abrasivi, ghisa e metalli in genere. Suitable for steel with R ≤ 900 N/mm<sup>2</sup>, quite abrasive materials, cast iron, metals. Para los aceros con R ≤ 900 N/mm<sup>2</sup>, materiales mediamente abrasivos, fundición y todos los metales. / Pour les aciers avec R ≤ 900 N/mm<sup>2</sup>, matériaux modérément abrasifs, de la fonte et tous les métaux.

# 10360

## Maschi a macchina a rullare, fil. metrica ISO a passo grosso

Cold forming machine taps, ISO thread/ Tarauds à refouler

Machos de maquina laminacion / Maschinengewindefurher

<b>HSS CO5</b>	<b>DIN 371</b> M3±10	<b>DIN 376</b> M12±16		<b>ISO2X 6HX</b>	<b>M</b>	<b>Speciale per lamiere</b> Special for metal sheets
----------------	-------------------------	--------------------------	---	------------------	----------	---

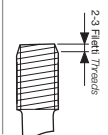

**TiN**  
HV 0,05  
2300

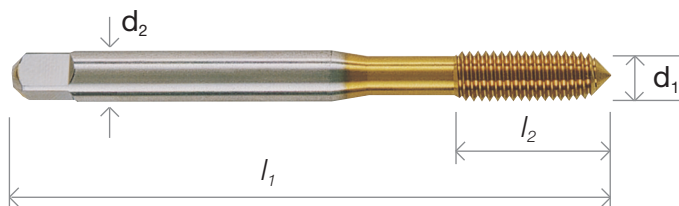

$d_1$	$l_2$	$l_1$	$d_2$	preforo drill	pcs	cod.	€ cad/each
<b>DIN 371</b>							
<b>M 3</b> x 0,5	11	56	3,5	2,80	1	1036003X05	38,171
<b>4</b> x 0,7	13	63	4,5	3,70	1	1036004X07	41,918
<b>5</b> x 0,8	16	70	6,0	4,65	1	1036005X08	49,183
<b>6</b> x 1	19	80	6,0	5,55	1	1036006X1	49,183
<b>8</b> x 1,25	22	90	8,0	7,45	1	1036008X125	58,705
<b>10</b> x 1,5	24	100	10	9,30	1	1036010X15	68,962

<b>DIN 376</b>							
<b>M 12</b> x 1,75	29	110	9,0	11,20	1	1036012X175	100,975
<b>14</b> x 2	30	110	11	13,0	1	1036014X2	136,682
<b>16</b> x 2	32	110	12	15,1	1	1036016X2	151,462



<b>2,5</b> $d_1$						<b>Lubrorefrigerazione con olio</b> o <b>grafite raccomandata</b> Recommended oil or graphite cooling
	Inox	Acciaio Steel	Metals	Alu		

Alto rendimento nella filettatura in acciai ad elevata resistenza sino a  $R_s \leq 1200 \text{ N/mm}^2$ , quali acciai da bonifica alto legati, acciai inox, acciai resistenti agli acidi, acciai refrattari. Temperatura max. di lavoro  $550^\circ$ . High performances in high strength steel  $R_s \leq 1200 \text{ N/mm}^2$ , stainless steel, acid resistant steel, high alloy construction steel. / Haute rendement en taraudage des aciers alliés traités, acier inox, acier refractaire avec  $R_s \leq 1200 \text{ N/mm}^2$  / Alto rendimento en taladro de acero de alta resistencia de hasta  $R_s \leq 1200 \text{ N/mm}^2$ , acero inox, acero tratado, etc... / Breites anwendungsspektrum u.a. für gut Spanbare Stähle, rostfrei Stähle, Säurebeständigstähle und Vergütungsstähle bis  $1200 \text{ N/mm}^2$ .



## 10281

### Maschi a macchina a rullare, fil. metrica ISO a passo grosso

Cold forming machine taps, ISO thread/ Tarauds à refouler

Machos de maquina laminacion / Maschinengewindfurcher

<b>HSS CO5</b>	<b>DIN 371</b>	<b>DIN 376</b>		<b>ISO2X 6HX</b>	<b>M</b>	<b>Speciale per lamiere Special for metal sheets</b>
	<b>M3±10</b>	<b>M12±16</b>				

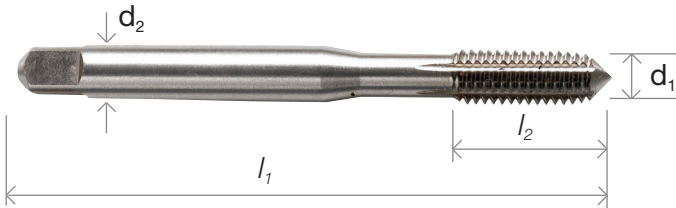
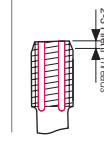

d <sub>1</sub>	l <sub>2</sub>	l <sub>1</sub>	d <sub>2</sub>	preforo drill	pcs	cod.	€ cad/each
<b>DIN 371</b>							
<b>M 3 x 0,5</b>	11	56	3,5	2,80	1	1028103X05	30,605
<b>4 x 0,7</b>	13	63	4,5	3,70	1	1028104X07	34,445
<b>5 x 0,8</b>	16	70	6,0	4,65	1	1028105X08	38,274
<b>6 x 1</b>	19	80	6,0	5,55	1	1028106X1	38,274
<b>8 x 1,25</b>	22	90	8,0	7,45	1	1028108X125	45,488
<b>10 x 1,5</b>	24	100	10	9,30	1	1028110X15	52,619
<b>DIN 376</b>							
<b>M 12 x 1,75</b>	29	110	9,0	11,20	1	1028112X175	66,043
<b>14 x 2</b>	30	110	11	13,0	1	1028114X2	98,066
<b>16 x 2</b>	32	110	12	15,1	1	1028116X2	118,218

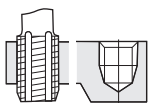

**Con canali di lubrificazione**  
With oil grooves

<b>2,5 d<sub>1</sub></b>						<b>Lubrorefrigerazione con olio o grafite raccomandata</b> Recommended oil or graphite cooling
	Inox	Acciaio Steel	Metals	Alu		

Per acciai con R ≤ 900 N/mm<sup>2</sup>, materiali mediamente abrasivi, ghisa e metalli in genere. Suitable for steel with R ≤ 900 N/mm<sup>2</sup>, quite abrasive materials, cast iron, metals. Para los aceros con R ≤ 900 N/mm<sup>2</sup>, materiales mediamente abrasivos, fundición y todos los metales. / Pour les aciers avec R ≤ 900 N/mm<sup>2</sup>, matériaux modérément abrasifs, de la fonte et tous les métaux.

# 10361

## Maschi a macchina a rollare, fil. metrica ISO a passo grosso

Cold forming machine taps, ISO thread/ Tarauds à refouler

Machos de maquina laminacion / Maschinengewindefurher

**HSS  
CO5**

**DIN  
371**

**DIN  
376**



**ISO2X  
6HX**

**M**

**Speciale per lamiere  
Special for metal sheets**

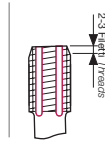

**TiN**

**HV 0,05  
2300**

**M3±10 M12±16**

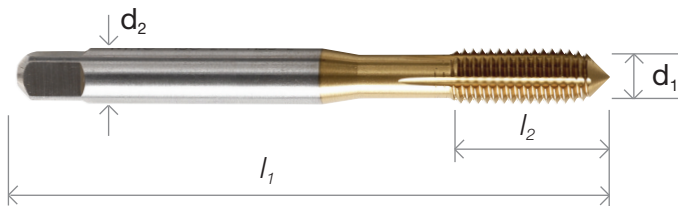

$d_1$   $l_2$   $l_1$   $d_2$  **preforo** **pcs** **cod.** **€**  
cad/each

### DIN 371

<b>M 3 x 0,5</b>	11	56	3,5	2,80	1	1036103X05	40,199
<b>4 x 0,7</b>	13	63	4,5	3,70	1	1036104X07	43,874
<b>5 x 0,8</b>	16	70	6,0	4,65	1	1036105X08	47,237
<b>6 x 1</b>	19	80	6,0	5,55	1	1036106X1	48,924
<b>8 x 1,25</b>	22	90	8,0	7,45	1	1036108X125	59,316
<b>10 x 1,5</b>	24	100	10	9,30	1	1036110X15	71,374

### DIN 376

<b>M 12 x 1,75</b>	29	110	9,0	11,20	1	1036112X175	95,510
<b>14 x 2</b>	30	110	11	13,0	1	1036114X2	130,472
<b>16 x 2</b>	32	110	12	15,1	1	1036116X2	153,977

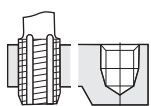

**Con canali di lubrificazione**  
With oil grooves

**2,5  
 $d_1$**



**Lubrorefrigerazione con olio  
o grafite raccomandata**  
Recommended oil or graphite cooling

Alto rendimento nella filettatura in acciai ad elevata resistenza sino a  $R_s \approx 1200 \text{ N/mm}^2$ , quali acciai da bonifica alto legati, acciai inox, acciai resistenti agli acidi, acciai refrattari. Temperatura max. di lavoro  $550^\circ$ . High performances in high strength steel  $R_s \approx 1200 \text{ N/mm}^2$ , stainless steel, acid resistant steel, high alloy construction steel. / Haute rendement en taraudage des aciers alliés traités, acier inox, acier refractaire avec  $R_s \approx 1200 \text{ N/mm}^2$  / Alto rendimento en taladro de acero de alta resistencia de hasta  $R_s \approx 1200 \text{ N/mm}^2$ , acero inox, acero tratado, etc... / Breites anwendungsspektrum u.a. für gut Spanbare Stähle, rostfrei Stähle, Säurebeständigstähle und Vergütungsstähle bis  $1200 \text{ N/mm}^2$ .

## 10268

### Maschi a macchina, filettatura gas cilindrica BSP

Machine taps, BSP pipe-thread / Tarauds machine, filetage gaz BSP

Machos de maquina, rosca gas BSP / Maschinengewindebohrer für Rohrgewinde

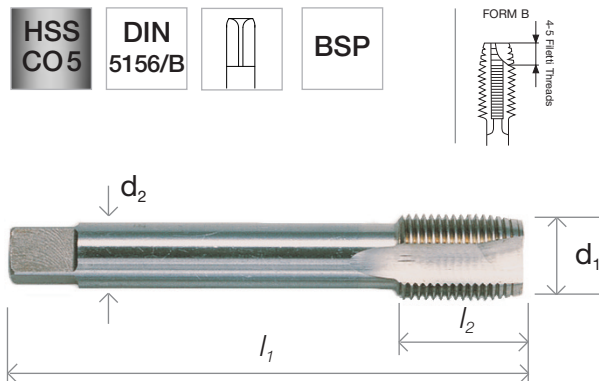

	d <sub>1</sub>	l <sub>2</sub>	l <sub>1</sub>	d <sub>2</sub>	pcs	cod.	€
							cad/each
<b>G</b>	1/8 x 28	20	90	7	1	102681/8	29,332
	1/4 x 19	22	100	11	1	102681/4	38,285
	3/8 x 19	22	100	12	1	102683/8	44,898
	1/2 x 14	25	125	16	1	102681/2	66,747
	5/8 x 14	25	125	18	1	102685/8	72,947
	3/4 x 14	28	140	20	1	102683/4	101,430
	7/8 x 14	28	150	22	1	102687/8	109,710

	d <sub>1</sub>	l <sub>2</sub>	l <sub>1</sub>	d <sub>2</sub>	pcs	cod.	€
							cad/each
<b>G</b>	1" x 11	30	160	25	1	102681"	146,929
	1.1/8 x 11	30	170	28	1	102681.1/8	247,396
	1.1/4 x 11	30	170	32	1	102681.1/4	319,049
	1.3/8 x 11	32	180	36	1	102681.3/8	430,995
	1.1/2 x 11	32	190	36	1	102681.1/2	486,968
	1.3/4 x 11	32	190	40	1	102681.3/4	578,762
	2" x 11	40	220	45	1	102682"	620,182

## 10276

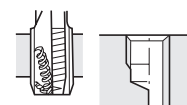
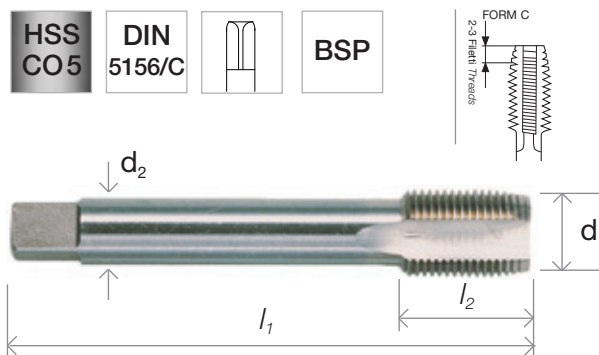

	d <sub>1</sub>	l <sub>2</sub>	l <sub>1</sub>	d <sub>2</sub>	pcs	cod.	€
							cad/each
<b>G</b>	1/8 x 28	20	90	7	1	102761/8	31,826
	1/4 x 19	22	100	11	1	102761/4	39,972
	3/8 x 19	22	100	12	1	102763/8	49,970
	1/2 x 14	25	125	16	1	102761/2	70,484
	5/8 x 14	25	125	18	1	102765/8	80,213
	3/4 x 14	28	140	20	1	102763/4	103,883
	7/8 x 14	28	150	22	1	102767/8	122,296

	d <sub>1</sub>	l <sub>2</sub>	l <sub>1</sub>	d <sub>2</sub>	pcs	cod.	€
							cad/each
<b>G</b>	1" x 11	30	160	25	1	102761"	151,224
	1.1/8 x 11	30	170	28	1	102761.1/8	210,571
	1.1/4 x 11	30	170	32	1	102761.1/4	280,764
	1.3/8 x 11	32	180	36	1	102761.3/8	386,655
	1.1/2 x 11	32	190	36	1	102761.1/2	411,288
	1.3/4 x 11	32	190	40	1	102761.3/4	501,178
	2" x 11	40	220	45	1	102762"	543,044



# 10267

## Maschi a macchina, filettatura gas cilindrica BSP

Machine taps, BSP pipe-thread / Tarauds machine, filetage gaz BSP

Machos de maquina, rosca gas BSP / Maschinengewindebohrer für Rohrgewinde

HSS  
CO 5

DIN  
5156/C

35°



BSP

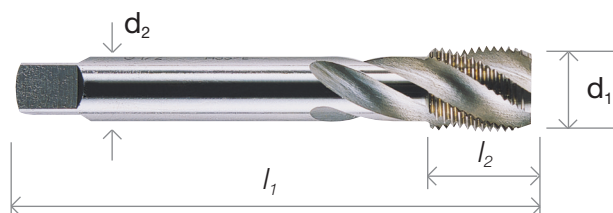
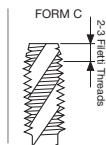

$d_1$	$l_2$	$l_1$	$d_2$	pcs 	cod.	€ cad/each
<b>G 1/8</b> x 28	20	90	7	1	102671/8	32,665
<b>1/4</b> x 19	22	100	11	1	102671/4	50,239
<b>3/8</b> x 19	22	100	12	1	102673/8	64,532
<b>1/2</b> x 14	25	125	16	1	102671/2	105,839
<b>5/8</b> x 14	25	125	18	1	102675/8	121,416
<b>3/4</b> x 14	28	140	20	1	102673/4	159,504
<b>7/8</b> x 14	28	150	22	1	102677/8	192,520
<b>1"</b> x 11	30	160	25	1	102671"	231,995
<b>1.1/8</b> x 11	30	170	28	1	102671.1/8	328,271
<b>1.1/4</b> x 11	30	170	32	1	102671.1/4	397,471
<b>1.3/8</b> x 11	32	180	36	1	102671.3/8	577,644
<b>1.1/2</b> x 11	32	190	36	1	102671.1/2	611,219
<b>1.3/4</b> x 11	32	190	40	1	102671.3/4	879,305
<b>2"</b> x 11	40	220	45	1	102672"	963,285

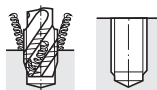

2  $d_1$



Per maschiature in acciai con  $R_s \leq 850$  N/mm<sup>2</sup>, ghisa malleabile, metalli non ferrosi a truciolo lungo, acciai resistenti al calore, acciai refrattari, acciai inox.  
 For threading steel with  $R_s \leq 850$  N/mm<sup>2</sup>, malleable cast iron, nonferrous metal with long chips, heat-resistant and refractory steel, stainless steel. / Pour tarauder acier avec  $R_s \leq 850$  N/mm<sup>2</sup> fonte malléable, alliages légers, acier réfractaire et acier inoxydable. / Para atarrajar acero con  $R_s \leq 850$  N/mm<sup>2</sup>, fundición, aleaciones ligeras, acero aleado y refractario, acero inoxidable. / Um in Stahl mit  $R_s \leq 850$  N/mm<sup>2</sup>, Temperguss, Nichteisenmetalle, hitzbeständigem Stahl und rostfreierem Stahl Gewinde zu bohren

## 10265

### Maschi a macchina, filettatura Inglese Whitworth a passo grosso

Machine taps, british standard thread / Tarauds machine, filetage BSW

Machos de maquina, rosca inglesa BSW / Maschinengewindebohrer, Whitworth-gewinde BS 84

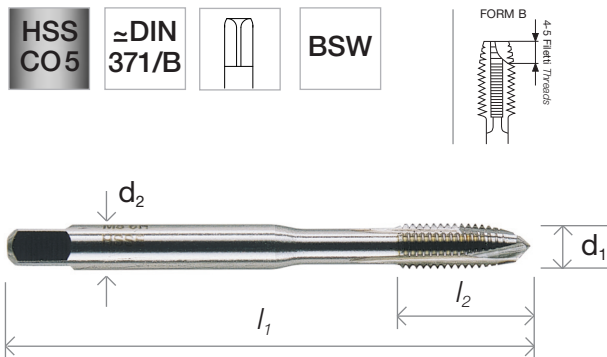

	$d_1$	$l_2$	$l_1$	$d_2$	pcs	cod.	€ cad/each
<b>BSW 1/8</b> x 40	5	56	3,5	1	102651/8	21,321	
<b>5/32</b> x 32	6	63	4,5	1	102655/32	21,321	
<b>3/16</b> x 24	9	70	5,5	1	102653/16	21,880	
<b>1/4</b> x 20	10	90	7	1	102651/4	21,880	
<b>5/16</b> x 18	12	90	8	1	102655/16	26,951	
<b>3/8</b> x 16	14	100	9	1	102653/8	30,263	



## 10266

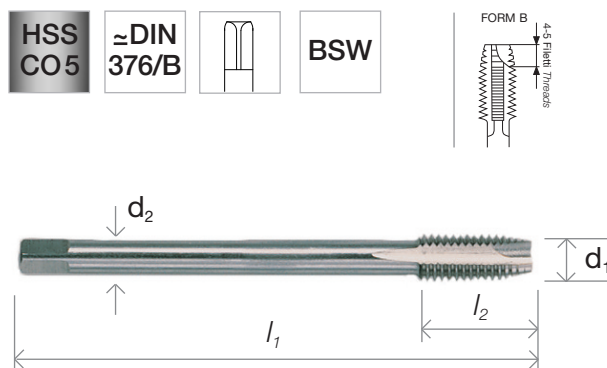

	$d_1$	$l_2$	$l_1$	$d_2$	pcs	cod.	€ cad/each
<b>BSW 7/16</b> x 14	20	100	8	1	102667/16	32,603	
<b>1/2</b> x 12	25	110	9	1	102661/2	32,913	
<b>9/16</b> x 12	25	110	11	1	102669/16	48,645	
<b>5/8</b> x 11	28	110	12	1	102665/8	48,645	
<b>3/4</b> x 10	32	125	14	1	102663/4	100,799	
<b>7/8</b> x 9	32	140	18	1	102667/8	113,850	
<b>1"</b> x 8	36	160	20	1	102661"	129,375	
<b>1.1/4</b> x 7	40	180	22	1	102661.1/4	192,096	
<b>1.1/2</b> x 6	50	200	32	1	102661.1/2	411,288	



Per maschiature in acciai con  $R_s \leq 850$  N/mm<sup>2</sup>, ghisa malleabile, metalli non ferrosi a truciolo lungo, acciai resistenti al calore, acciai refrattari, acciai inox.  
 For threading steel with  $R_s \leq 850$  N/mm<sup>2</sup>, malleable cast iron, nonferrous metal with long chips, heat-resistant and refractory steel, stainless steel. / Pour tarauder  
 acier avec  $R_s \leq 850$  N/mm<sup>2</sup> fonte malléable, alliages légers, acier réfractaire et acier inoxydable. / Para atarrajar acero con  $R_s \leq 850$  N/mm<sup>2</sup>, fundición, aleaciones  
 ligeras, acero aleado y refractario, acero inoxidable. / Um in Stahl mit  $R_s \leq 850$  N/mm<sup>2</sup>, Temperguss, Nichteisenmetalle, hitzbeständigem Stahl und rostfreierem Stahl  
 Gewinde zu bohren

# 10274

## Maschi a macchina, filettatura Inglese Whitworth a passo grosso

Machine taps, british standard thread / Tarauds machine, filetage BSW

Machos de maquina, rosca inglesa BSW / Maschinengewindebohrer, Whitworth-gewinde BS 84

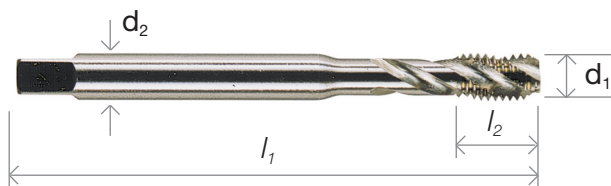
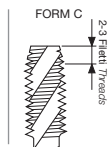
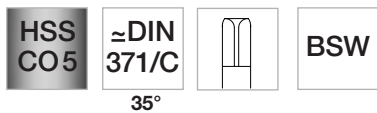

	$d_1$	$l_2$	$l_1$	$d_2$	pcs	cod.	€ cad/each
<b>BSW 1/8</b> x 40	5	56	3,5	1	102741/8	27,355	
<b>5/32</b> x 32	6	63	4,5	1	102745/32	27,355	
<b>3/16</b> x 24	9	70	5,5	1	102743/16	28,607	
<b>1/4</b> x 20	10	90	7	1	102741/4	28,607	
<b>5/16</b> x 18	12	90	8	1	102745/16	34,621	
<b>3/8</b> x 16	14	100	9	1	102743/8	40,096	

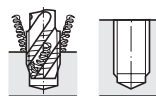

# 10275

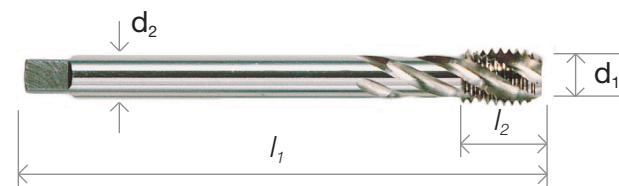
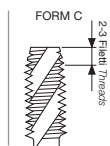
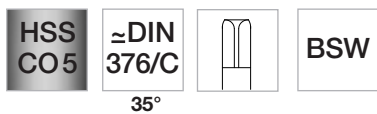

	$d_1$	$l_2$	$l_1$	$d_2$	pcs	cod.	€ cad/each
<b>BSW 7/16</b> x 14	20	100	8	1	102757/16	46,244	
<b>1/2</b> x 12	25	110	9	1	102751/2	46,244	
<b>9/16</b> x 12	25	110	11	1	102759/16	66,571	
<b>5/8</b> x 11	28	110	12	1	102755/8	66,571	
<b>3/4</b> x 10	32	125	14	1	102753/4	132,987	
<b>7/8</b> x 9	32	140	18	1	102757/8	176,095	
<b>1"</b> x 8	36	160	20	1	102751"	181,011	
<b>1.1/4</b> x 7	40	180	22	1	102751.1/4	265,985	
<b>1.1/2</b> x 6	50	200	32	1	102751.1/2	584,920	

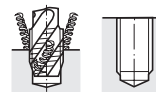

Per maschiature in acciai con  $R_s \leq 850 \text{ N/mm}^2$ , ghisa malleabile, metalli non ferrosi a truciolo lungo, acciai resistenti al calore, acciai refrattari, acciai inox.  
 For threading steel with  $R_s \leq 850 \text{ N/mm}^2$ , malleable cast iron, nonferrous metal with long chips, heat-resistant and refractory steel, stainless steel. / Pour tarauder acier avec  $R_s \leq 850 \text{ N/mm}^2$  fonte malléable, alliages légers, acier réfractaire et acier inoxydable. / Para atarrajar acero con  $R_s \leq 850 \text{ N/mm}^2$ , fundición, aleaciones ligeras, acero aleado y refractario, acero inoxidable. / Um in Stahl mit  $R_s \leq 850 \text{ N/mm}^2$ , Temperguss, Nichteisenmetalle, hitzbeständigem Stahl und rostfreierem Stahl Gewinde zu bohren

## 10269

### Maschi a macchina, filettatura Americana UNC a passo grosso

Machine taps, UNC american coarse thread / Tarauds machine, filetage americain UNC

Machos de maquina, rosca americana vasta UNC /Maschinengewindebohrer, amerikanisches großgewinde

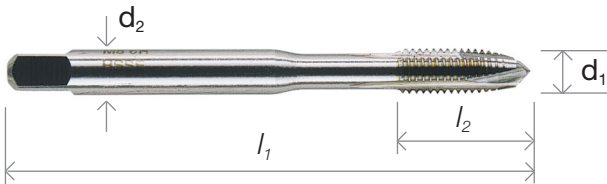
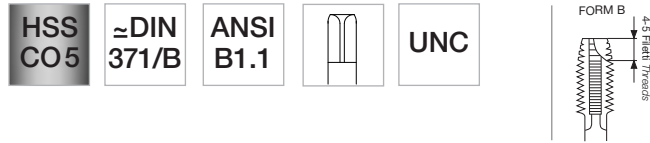

	$d_1$	$l_2$	$l_1$	$d_2$	pcs	cod.	€ cad/each
<b>UNC 6</b>	x 32	12	56	4	1	10269NR06	22,211
<b>8</b>	x 32	13	63	4,5	1	10269NR08	22,211
<b>10</b>	x 24	15	70	6	1	10269NR10	22,211
<b>12</b>	x 24	16	70	6	1	10269NR12	22,211
<b>1/4</b>	x 20	17	80	7	1	102691/4	22,211
<b>5/16</b>	x 18	20	90	8	1	102695/16	27,738
<b>3/8</b>	x 16	22	100	9	1	102693/8	31,474



## 10270

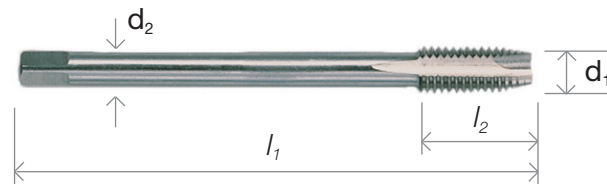
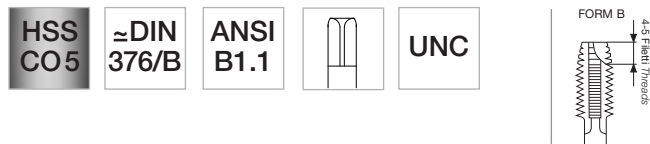

	$d_1$	$l_2$	$l_1$	$d_2$	pcs	cod.	€ cad/each
<b>UNC 7/16</b>	x 14	22	100	8	1	102707/16	36,991
<b>1/2</b>	x 13	25	110	9	1	102701/2	36,991
<b>9/16</b>	x 12	26	110	11	1	102709/16	55,476
<b>5/8</b>	x 11	27	110	12	1	102705/8	55,476
<b>3/4</b>	x 10	30	125	14	1	102703/4	107,257
<b>7/8</b>	x 9	32	140	18	1	102707/8	129,292
<b>1"</b>	x 8	36	160	20	1	102701"	147,767
<b>1.1/4</b>	x 7	40	180	22	1	102701.1/4	216,729
<b>1.1/2</b>	x 6	50	200	32	1	102701.1/2	502,410



La filettatura UNC trova applicazione nell'industria delle costruzioni perché consente un rapido assemblaggio ed è meno sensibile al danneggiamento rispetto alla filettatura UNF, avendo caratteristiche geometriche più resistenti. E' spesso usata con materiali a bassa resistenza. Unified National Coarse threads are often used in the construction industry. They allow rapid assembly and also provide greater resistance to internal thread stripping. They're mostly used with low strength material.

# 10271

## Maschi a macchina, filettatura Americana UNC a passo grosso

Machine taps, UNC american coarse thread / Tarauds machine, filetage americain UNC

Machos de maquina, rosca americana vasta UNC /Maschinengewindebohrer, amerikanisches großgewinde

HSS  
CO5

≈DIN  
371/C  
35°

ANSI  
B1.1



UNC

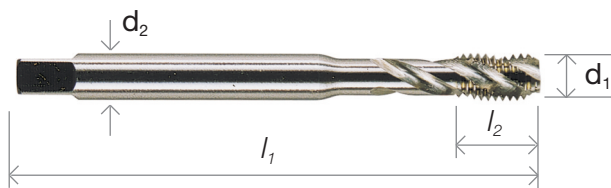
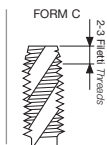

	$d_1$	$l_2$	$l_1$	$d_2$	pcs	cod.	€ cad/each
<b>UNC 6</b>	x 32	7	56	4	1	10271NR06	27,738
<b>8</b>	x 32	8	63	4,5	1	10271NR08	27,738
<b>10</b>	x 24	10	70	6	1	10271NR10	27,738
<b>12</b>	x 24	10	70	6	1	10271NR12	27,738
<b>1/4</b>	x 20	13	80	7	1	102711/4	27,738
<b>5/16</b>	x 18	14	90	8	1	102715/16	36,991
<b>3/8</b>	x 16	16	100	9	1	102713/8	38,129

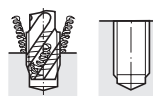

# 10272

HSS  
CO5

≈DIN  
376/C  
35°

ANSI  
B1.1



UNC

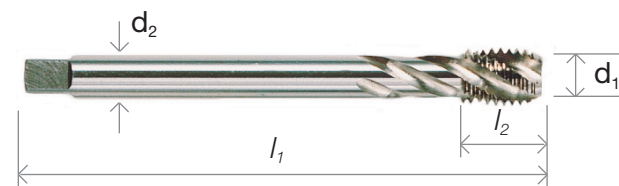
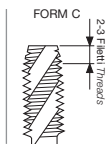

	$d_1$	$l_2$	$l_1$	$d_2$	pcs	cod.	€ cad/each
<b>UNC 7/16</b>	x 14	17	100	8	1	102727/16	46,244
<b>1/2</b>	x 13	20	110	9	1	102721/2	46,244
<b>9/16</b>	x 12	20	110	11	1	102729/16	66,571
<b>5/8</b>	x 11	22	110	12	1	102725/8	66,571
<b>3/4</b>	x 10	25	125	14	1	102723/4	132,987
<b>7/8</b>	x 9	27	140	18	1	102727/8	176,095
<b>1"</b>	x 8	30	160	20	1	102721"	181,011
<b>1.1/4</b>	x 7	35	180	22	1	102721.1/4	265,985
<b>1.1/2</b>	x 6	40	200	32	1	102721.1/2	584,920

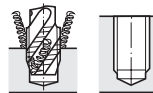

La filettatura UNC trova applicazione nell'industria delle costruzioni perché consente un rapido assemblaggio ed è meno sensibile al danneggiamento rispetto alla filettatura UNF, avendo caratteristiche geometriche più resistenti. E' spesso usata con materiali a bassa resistenza. Unified National Coarse threads are often used in the construction industry. They allow rapid assembly and also provide greater resistance to internal thread stripping. They're mostly used with low strength material.



## 10282

### Maschi a macchina, filettatura Americana UNF a passo fine

Machine taps, american UNF thread / Tarauds machine, filetage americain UNF

Machos de maquina, rosca americana fina UNF / Maschinengewindebohrer, amerikanisches feingewinde UNF

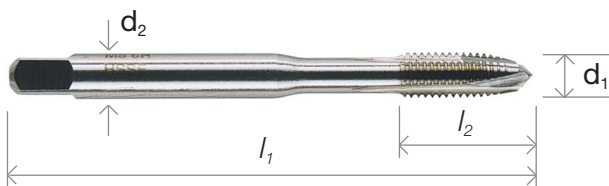
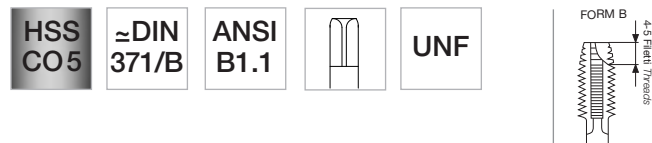

	d <sub>1</sub>	l <sub>2</sub>	l <sub>1</sub>	d <sub>2</sub>	pcs	cod.	€ cad/each
<b>UNF 6</b>	x 40	12	56	4	1	10282NR06	22,263
<b>8</b>	x 36	13	63	4,5	1	10282NR08	22,263
<b>10</b>	x 32	15	70	6	1	10282NR10	22,263
<b>12</b>	x 28	16	70	6	1	10282NR12	22,263
<b>1/4</b>	x 28	17	80	7	1	102821/4	22,263
<b>5/16</b>	x 24	17	90	8	1	102825/16	28,183
<b>3/8</b>	x 24	18	100	9	1	102823/8	31,060



## 10283

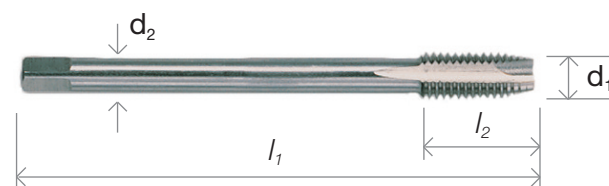

	d <sub>1</sub>	l <sub>2</sub>	l <sub>1</sub>	d <sub>2</sub>	pcs	cod.	€ cad/each
<b>UNF 7/16</b>	x 20	22	100	8	1	102837/16	35,801
<b>1/2</b>	x 20	22	100	9	1	102831/2	35,801
<b>9/16</b>	x 18	22	100	11	1	102839/16	54,814
<b>5/8</b>	x 18	22	100	12	1	102835/8	54,814
<b>3/4</b>	x 16	25	110	14	1	102833/4	107,330
<b>7/8</b>	x 14	26	140	18	1	102837/8	128,961
<b>1"</b>	x 14	28	150	20	1	102831"	143,741
<b>1.1/4</b>	x 12	30	150	22	1	102831.1/4	202,115
<b>1.1/2</b>	x 12	33	170	32	1	102831.1/2	467,313



La filettatura UNF è spesso usata con viti e bulloni ad alta resistenza grazie al maggior diametro di nocciolo e alla minore profondità di filetto rispetto alla filettatura UNC. Il filetto UNF è perciò più resistente all'allentamento da vibrazione rispetto al filetto UNC, ma soffre di più le sollecitazioni longitudinali. Unified National Fine threads are frequently used with high strength bolts because they have less thread depth and a greater minor diameter if compared to UNC threads. UNF threads are stronger and more resistant to vibration loosening than UNC threads, but are susceptible to damage and cross threading.

# 10284

## Maschi a macchina, filettatura Americana UNF a passo fine

Machine taps, american UNF thread / Tarauds machine, filetage americain UNF

Machos de maquina, rosca americana fina UNF / Maschinengewindebohrer, amerikanisches feingewinde UNF

HSS  
CO5

≈DIN  
371/C  
35°

ANSI  
B1.1



UNF

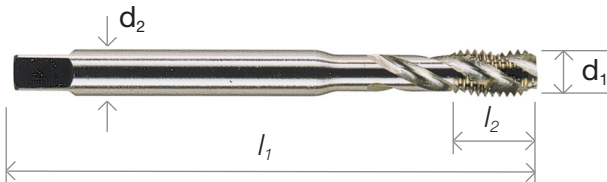
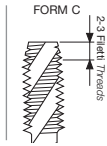

	d <sub>1</sub>	l <sub>2</sub>	l <sub>1</sub>	d <sub>2</sub>	pcs	cod.	€ cad/each
<b>UNF 6</b>	x 40	7	56	4	1	10284NR06	28,928
<b>8</b>	x 36	8	63	4,5	1	10284NR08	28,928
<b>10</b>	x 32	10	70	6	1	10284NR10	28,928
<b>12</b>	x 28	10	70	6	1	10284NR12	28,928
<b>1/4</b>	x 28	10	80	7	1	102841/4	28,928
<b>5/16</b>	x 24	10	90	8	1	102845/16	34,931
<b>3/8</b>	x 24	10	100	9	1	102843/8	39,868

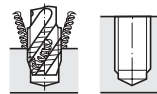

# 10285

HSS  
CO5

≈DIN  
376/C  
35°

ANSI  
B1.1



UNF

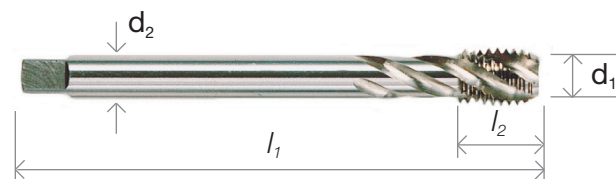
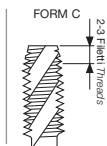

	d <sub>1</sub>	l <sub>2</sub>	l <sub>1</sub>	d <sub>2</sub>	pcs	cod.	€ cad/each
<b>UNF 7/16</b>	x 20	13	100	8	1	102857/16	45,219
<b>1/2</b>	x 20	13	100	9	1	102851/2	45,219
<b>9/16</b>	x 18	15	100	11	1	102859/16	67,824
<b>5/8</b>	x 18	15	100	12	1	102855/8	67,824
<b>3/4</b>	x 16	17	110	14	1	102853/4	151,131
<b>7/8</b>	x 14	17	140	18	1	102857/8	166,242
<b>1"</b>	x 14	20	150	20	1	102851"	182,864
<b>1.1/4</b>	x 12	22	150	22	1	102851.1/4	237,263
<b>1.1/2</b>	x 12	25	170	32	1	102851.1/2	590,902

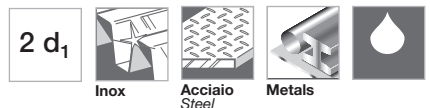
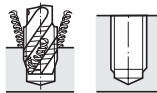

La filettatura UNF è spesso usata con viti e bulloni ad alta resistenza grazie al maggior diametro di nocciolo e alla minore profondità di filetto rispetto alla filettatura UNC. Il filetto UNF è perciò più resistente all'allentamento da vibrazione rispetto al filetto UNC, ma soffre di più le sollecitazioni longitudinali. Unified National Fine threads are frequently used with high strength bolts because they have less thread depth and a greater minor diameter if compared to UNC threads. UNF threads are stronger and more resistant to vibration loosening than UNC threads, but are susceptible to damage and cross threading.

## 10301

### Maschi a macchina corti ISO 529 filettatura Americana UN

Short machine taps, American UN thread / Tarauds machine courte

Machos de maquina cortos / Kurzmaschinen-Gewindebohrer.

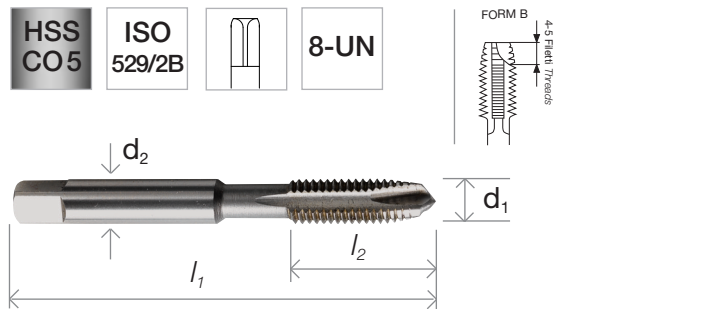

	d <sub>1</sub>	l <sub>2</sub>	l <sub>1</sub>	d <sub>2</sub>	pcs	cod.	€ cad/each
<b>UN</b>	<b>1.1/8 x 8</b>	48	138	20,0	1	103011.1/8	152,280
	<b>1.1/4 x 8</b>	51	151	22,4	1	103011.1/4	177,875
	<b>1.1/2 x 8</b>	60	170	28,0	1	103011.1/2	291,073
	<b>1.3/4 x 8</b>	67	187	31,5	1	103011.3/4	393,486
	<b>2" x 8</b>	70	200	35,5	1	103012"	609,098
	<b>2.1/4 x 8</b>	76	221	40,0	1	103012.1/4	1204,730
	<b>2.1/2 x 8</b>	79	224	40,0	1	103012.1/2	1751,841
	<b>3" x 8</b>	83	258	50,0	1	103013"	2142,636
	<b>3.1/2 x 8</b>	86	261	50,0	1	103013.1/2	2519,956
	<b>4" x 8</b>	89	279	56,0	1	103014"	3099,411

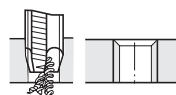

## 10302



	d <sub>1</sub>	l <sub>2</sub>	l <sub>1</sub>	d <sub>2</sub>	pcs	cod.	€ cad/each
<b>UN</b>	<b>1.3/4 x 12</b>	67	187	31,5	1	103021.3/4	393,486
	<b>2" x 12</b>	70	200	35,5	1	103022"	609,098
	<b>2.1/4 x 12</b>	76	221	40,0	1	103022.1/4	1204,730
	<b>2.1/2 x 12</b>	79	224	40,0	1	103022.1/2	1751,841
	<b>3" x 12</b>	83	258	50,0	1	103023"	2142,636
	<b>3.1/2 x 12</b>	86	261	50,0	1	103023.1/2	2519,956
	<b>4" x 12</b>	89	279	56,0	1	103024"	3099,411

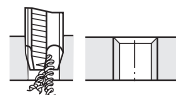

La filettatura 8-UN trova impiego per lo più in giunzioni sottoposte ad alte temperature e alte pressioni. E' anche usata come compromesso tra le filettature UNC e UNF perché risulta più resistente all'allentamento dovuto alle vibrazioni rispetto al filetto UNC. 8-thread series is characterized by 8 threads per inch regardless of diameter and it's generally used on diameters  $\geq 1"$ . They're used in high-pressure and/or high-temperature joint applications. They're more resistant to vibration loosening than UNC threads.

# 10303

## Maschi a macchina corti ISO 529 filettatura Americana UN

Short machine taps, American UN thread / Tarauds machine courte

Machos de maquina cortos / Kurzmaschinen-Gewindebohrer.

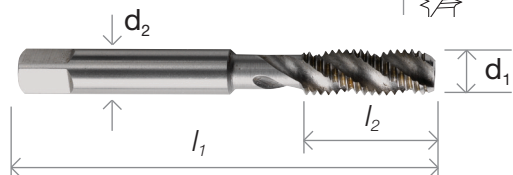
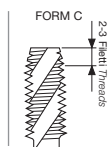

	$d_1$	$l_2$	$l_1$	$d_2$	pcs	cod.	€ cad/each
UN	1.1/8 x 8	48	138	20,0	1	103031.1/8	191,351
	1.1/4 x 8	51	151	22,4	1	103031.1/4	223,695
	1.1/2 x 8	60	170	28,0	1	103031.1/2	363,844
	1.3/4 x 8	67	187	31,5	1	103031.3/4	490,518
	2" x 8	70	200	35,5	1	103032"	760,032
	2.1/4 x 8	76	221	40,0	1	103032.1/4	1509,278
	2.1/2 x 8	79	224	40,0	1	103032.1/2	2191,147
	3" x 8	83	258	50,0	1	103033"	2681,664
	3.1/2 x 8	86	261	50,0	1	103033.1/2	3153,314
	4" x 8	89	279	56,0	1	103034"	3907,953

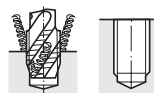

# 10304

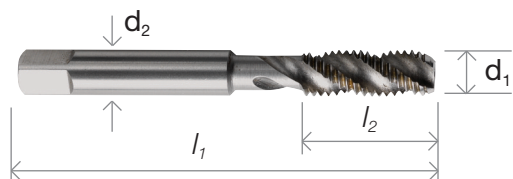
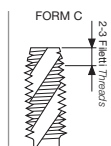

	$d_1$	$l_2$	$l_1$	$d_2$	pcs	cod.	€ cad/each
UN	1.3/4 x 12	67	187	31,5	1	103041.3/4	490,518
	2" x 12	70	200	35,5	1	103042"	760,032
	2.1/4 x 12	76	221	40,0	1	103042.1/4	1509,278
	2.1/2 x 12	79	224	40,0	1	103042.1/2	2191,147
	3" x 12	83	258	50,0	1	103043"	2681,664
	3.1/2 x 12	86	261	50,0	1	103043.1/2	3153,314
	4" x 12	89	279	56,0	1	103044"	3907,953

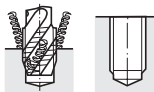

La filettatura 8-UN trova impiego per lo più in giunzioni sottoposte ad alte temperature e alte pressioni. E' anche usata come compromesso tra le filettature UNC e UNF perché risulta più resistente all'allentamento dovuto alle vibrazioni rispetto al filetto UNC. 8-thread series is characterized by 8 threads per inch regardless of diameter and it's generally used on diameters  $\geq 1"$ . They're used in high-pressure and/or high-temperature joint applications. They're more resistant to vibration loosening than UNC threads.

## 10305

### Maschi a macchina corti ISO 529 filettatura Americana UNEF

Short machine taps, American UNEF thread / Tarauds machine courte

Machos de maquina cortos / Kurzmaschinen-Gewindebohrer.

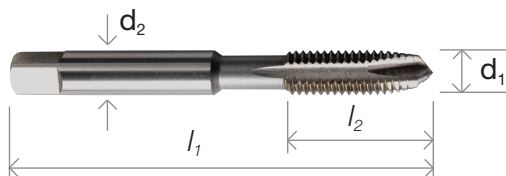
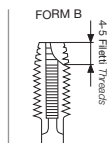

	$d_1$	$l_2$	$l_1$	$d_2$	pcs 	cod.	€ cad/each
<b>UNEF 1/4 x 32</b>	19	66	6,3	1	103051/4	19,406	
<b>5/16 x 32</b>	22	72	6,3	1	103055/16	27,490	
<b>3/8 x 32</b>	24	80	10,0	1	103053/8	27,490	
<b>1/2 x 28</b>	29	89	9,0	1	103051/2	32,344	
<b>9/16 x 24</b>	30	95	11,2	1	103059/16	48,780	
<b>5/8 x 24</b>	32	102	12,5	1	103055/8	49,856	
<b>3/4 x 20</b>	37	112	14,0	1	103053/4	92,177	
<b>7/8 x 20</b>	38	118	16,0	1	103057/8	113,198	
<b>1" x 20</b>	45	130	18,0	1	103051"	129,365	
<b>1.1/16 x 18</b>	48	138	20,0	1	103051.1/16	152,280	
<b>1.1/8 x 18</b>	48	138	20,0	1	103051.1/8	152,280	
<b>1.1/4 x 18</b>	51	151	22,4	1	103051.1/4	177,875	
<b>1.1/2 x 18</b>	60	170	28,0	1	103051.1/2	291,073	
<b>1.3/4 x 18</b>	67	187	31,5	1	103051.3/4	393,486	
<b>2" x 18</b>	70	200	35,5	1	103052"	609,098	

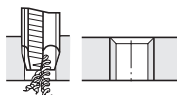

Per maschiature in acciai con  $R_s \leq 850 \text{ N/mm}^2$ , ghisa malleabile, metalli non ferrosi a truciolo lungo, acciai resistenti al calore, acciai refrattari, acciai inox.  
 For threading steel with  $R_s \leq 850 \text{ N/mm}^2$ , malleable cast iron, nonferrous metal with long chips, heat-resistant and refractory steel, stainless steel. / Pour tarauder acier avec  $R_s \leq 850 \text{ N/mm}^2$  fonte malléable, alliages légers, acier réfractaire et acier inoxydable. / Para atarrajar acero con  $R_s \leq 850 \text{ N/mm}^2$ , fundición, aleaciones ligeras, acero aleado y refractario, acero inoxidable. / Um in Stahl mit  $R_s \leq 850 \text{ N/mm}^2$ , Temperguss, Nichteisenmetalle, hitzbeständigem Stahl und rostfreierem Stahl Gewinde zu bohren

# 10277

## Maschi a macchina "sinistri", filettatura metrica ISO a passo grosso

Machine taps, "left hand", metric coarse thread / Tarauds machine, "gauche", filetage métrique

Machos de maquina, "izquierda", rosca metrica normal / Maschinengewindebohrer, "linksgewinde", für metrisches ISO Regelgewinde.

HSS  
CO5

DIN  
371/B



ISO2  
6H

M

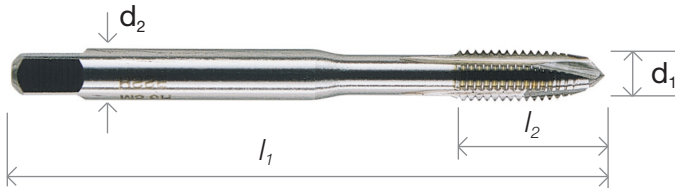
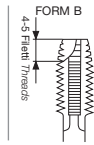

d <sub>1</sub>	l <sub>2</sub>	l <sub>1</sub>	d <sub>2</sub>	pcs	cod.	€ cad/each
M 3 x 0,5	11	56	3,5	1	1027703X05	28,763
4 x 0,7	13	63	4,5	1	1027704X07	28,763
5 x 0,8	16	70	6,0	1	1027705X08	29,539
6 x 1	19	80	6,0	1	1027706X1	29,539
8 x 1,25	22	90	8,0	1	1027708X125	36,122
10 x 1,5	24	100	10,0	1	1027710X15	41,058

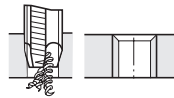

# 10278

HSS  
CO5

DIN  
376/B



ISO2  
6H

M

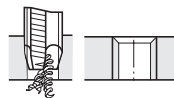
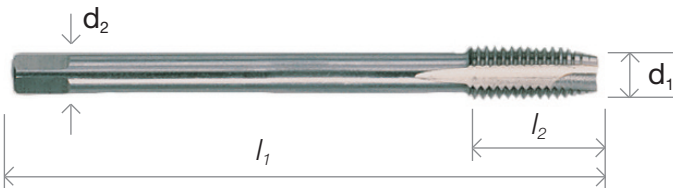
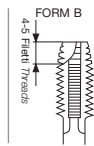

d <sub>1</sub>	l <sub>2</sub>	l <sub>1</sub>	d <sub>2</sub>	pcs	cod.	€ cad/each
M 12 x 1,75	29	110	9,0	1	1027812X175	49,287
14 x 2	30	110	11,0	1	1027814X2	61,593
16 x 2	32	110	12,0	1	1027816X2	68,962
18 x 2,5	34	125	14,0	1	1027818X25	94,423
20 x 2,5	34	140	16,0	1	1027820X25	136,620
22 x 2,5	34	140	18,0	1	1027822X25	170,402
24 x 3	38	160	18,0	1	1027824X3	182,574
27 x 3	38	160	20,0	1	1027827X3	302,769

d <sub>1</sub>	l <sub>2</sub>	l <sub>1</sub>	d <sub>2</sub>	pcs	cod.	€ cad/each
M 30 x 3,5	45	180	22,0	1	1027830X35	316,462
33 x 3,5	50	180	25,0	1	1027833X35	429,049
36 x 4	56	200	28,0	1	1027836X4	721,167
39 x 4	60	200	32,0	1	1027839X4	906,784
42 x 4,5	60	200	32,0	1	1027842X45	1077,187
45 x 4,5	65	220	36,0	1	1027845X45	1186,731
48 x 5	70	250	36,0	1	1027848X5	1308,447
52 x 5	70	250	40,0	1	1027852X5	1551,879

2,5  
d<sub>1</sub>



Per maschiature in acciai con R<sub>s</sub> 850 N/mm<sup>2</sup>, ghisa malleabile, metalli non ferrosi a truciolo lungo, acciai resistenti al calore, acciai refrattari, acciai inox.  
For threading steel with R<sub>s</sub> 850 N/mm<sup>2</sup>, malleable cast iron, nonferrous metal with long chips, heat-resistant and refractory steel, stainless steel. / Pour tarauder acier avec R<sub>s</sub> 850 N/mm<sup>2</sup> fonte malléable, alliages légers, acier réfractaire et acier inoxydable. / Para atarrajar acero con R<sub>s</sub> 850 N/mm<sup>2</sup>, fundición, aleaciones ligeras, acero aleado y refractario, acero inoxidable. / Um in Stahl mit R<sub>s</sub> 850 N/mm<sup>2</sup>, Temperguss, Nichteisenmetalle, hitzbeständigem Stahl und rostfreierem Stahl Gewinde zu bohren

## 10263

### Maschi a macchina "sinistri", filettatura metrica ISO a passo grosso

Machine taps, "left hand", metric coarse thread / Tarauds machine, "gauche", filetage métrique

Machos de maquina, "izquierda", rosca metrica normal / Maschinengewindebohrer, "linksgewinde", für metrisches ISO Regelgewinde.

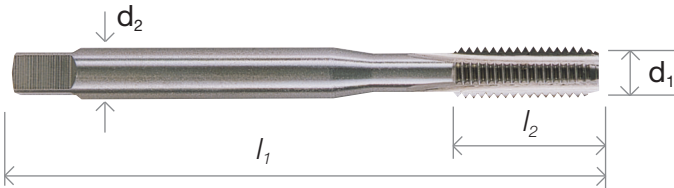

$d_1$	$l_2$	$l_1$	$d_2$	pcs	cod.	€
						cad/each
<b>M 3 x 0,5</b>	11	56	3,5	1	1026303X05	25,213
<b>4 x 0,7</b>	13	63	4,5	1	1026304X07	25,213
<b>5 x 0,8</b>	16	70	6,0	1	1026305X08	26,103
<b>6 x 1</b>	19	80	6,0	1	1026306X1	26,103
<b>8 x 1,25</b>	22	90	8,0	1	1026308X125	31,681
<b>10 x 1,5</b>	24	100	10,0	1	1026310X15	36,018

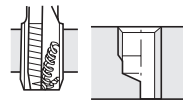

## 10264

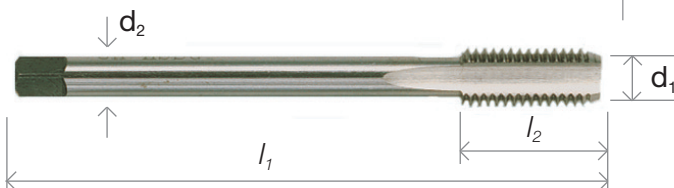

$d_1$	$l_2$	$l_1$	$d_2$	pcs	cod.	€
						cad/each
<b>M 12 x 1,75</b>	29	110	9,0	1	1026412X175	42,839
<b>14 x 2</b>	30	110	11,0	1	1026414X2	60,413
<b>16 x 2</b>	30	110	12,0	1	1026416X2	68,331
<b>18 x 2,5</b>	34	125	14,0	1	1026418X25	94,092
<b>20 x 2,5</b>	34	140	16,0	1	1026420X25	130,534
<b>22 x 2,5</b>	34	140	18,0	1	1026422X25	137,914
<b>24 x 3</b>	38	160	18,0	1	1026424X3	147,767

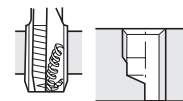

Per fori ciechi e passanti in acciai con  $R_s \leq 850 \text{ N/mm}^2$  ghisa malleabile, metalli non ferrosi a truciolo lungo, acciai resistenti al calore, acciai inox. For blind and through holes in steel with  $R_s \leq 850 \text{ N/mm}^2$  malleable cast iron, non ferrous metal with long chips, stainless steel, heat resistant steel. / Pour trous débouchants et borgnes en acier avec  $R_s \leq 850 \text{ N/mm}^2$  fonte, alliages légers, acier inoxydable. / Para orificios pasantes y ciegos en acero de hasta  $R_s \leq 850 \text{ N/mm}^2$  aleaciones ligeras, fundición, acero aleado y acero inox. / Für grund- und durchgangsloch in Stahl mit  $R_s \leq 850 \text{ N/mm}^2$ , Stahlguss, alu langspanend, korrosions-beständige Stähle (V2A-V4A) etc.

# 10279

## Maschi a macchina "sinistri", scanalature 35°, imb. "C", fil. metrica ISO

Machine taps "left hand", 35° spiral flute, metric coarse thread / Tarauds machine "gauche", goujures 35°, filetage métrique gros. /

Machos de maquina "izquierda", canal helicoidal 35°, rosca metrica vasta / Maschinen-Gewindebohrer "Linksgewinde", 35° rechtsspirale, für metrisches ISO-Regelgewinde

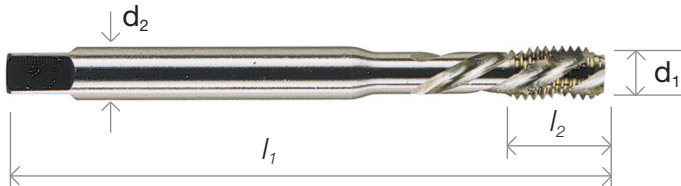
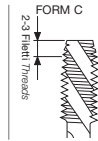

$d_1$	$l_2$	$l_1$	$d_2$	pcs	cod.	€
						cad/each
M 3 x 0,5	6	56	3,5	1	1027903X05	35,376
4 x 0,7	7	63	4,5	1	1027904X07	35,376
5 x 0,8	8	70	6,0	1	1027905X08	35,376
6 x 1	10	80	6,0	1	1027906X1	37,933
8 x 1,25	14	90	8,0	1	1027908X125	45,664
10 x 1,5	16	100	10,0	1	1027910X15	51,719

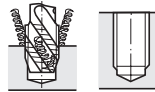

# 10288

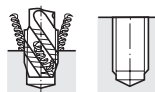
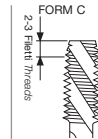

$d_1$	$l_2$	$l_1$	$d_2$	pcs	cod.	€
						cad/each
M 12 x 1,75	18	110	9,0	1	1028812X175	54,275
14 x 2	20	110	11,0	1	1028814X2	70,939
16 x 2	22	110	12,0	1	1028816X2	79,571
18 x 2,5	25	125	14,0	1	1028818X25	107,112
20 x 2,5	25	140	16,0	1	1028820X25	153,014
22 x 2,5	27	140	18,0	1	1028822X25	169,709
24 x 3	30	160	18,0	1	1028824X3	175,267
27 x 3	30	160	20,0	1	1028827X3	300,461

$d_1$	$l_2$	$l_1$	$d_2$	pcs	cod.	€
						cad/each
M 30 x 3,5	35	180	22,0	1	1028830X35	311,597
33 x 3,5	35	180	25,0	1	1028833X35	431,222
36 x 4	40	200	28,0	1	1028836X4	726,125
39 x 4	40	200	32,0	1	1028839X4	890,266
42 x 4,5	45	200	32,0	1	1028842X45	1043,280
45 x 4,5	45	220	36,0	1	1028845X45	1182,384
48 x 5	50	250	36,0	1	1028848X5	1290,883
52 x 5	50	250	40,0	1	1028852X5	1502,323

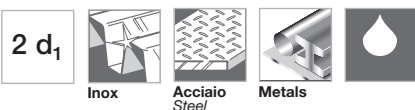

Per fori ciechi in acciai con  $R_s \leq 850 \text{ N/mm}^2$  ghisa malleabile, metalli non ferrosi, acciai resistenti al calore, acciai inox. For blind holes in steel with  $R_s \leq 850 \text{ N/mm}^2$  malleable cast iron, non ferrous metal, stainless steel, heat resistant steel. / Pour trous débouchants en acier avec  $R_s \leq 850 \text{ N/mm}^2$  fonte, alliages légers, acier inoxydable. / Para orificios ciegos in acero de hasta  $R_s \leq 850 \text{ N/mm}^2$  aleaciones ligeras, fundición, acero aleado y acero inox. / Für durchgangsloch in Stahl mit  $R_s \leq 850 \text{ N/mm}^2$ , Stahlguss, korrosions-beständige Stähle (V2A-V4A) etc.



## 10286

### Maschi a macchina "sinistri", filettatura metrica ISO a passo fine

Machine taps, "left hand", metric thread / TTarauds machine, "gauche", filetage métrique

Machos de maquina, "izquierda", rosca metrica / Maschinengewindebohrer, "linksgewinde", für metrisches ISO.

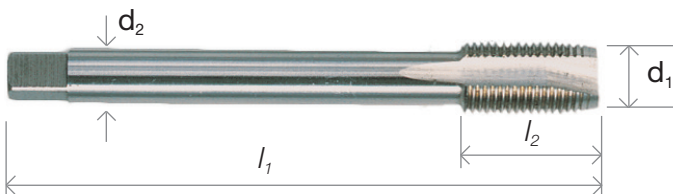

d <sub>1</sub>	l <sub>2</sub>	l <sub>1</sub>	d <sub>2</sub>	pcs	cod.	€ cad/each
M 4 x0,35	10	63	2,8	1	1028604X035	72,419
5 x0,5	12	70	3,5	1	1028605X05	72,419
6 x0,75	14	80	4,5	1	1028606X075	72,419
8 x0,75	19	80	6,0	1	1028608X075	72,419
8 x1	22	90	6,0	1	1028608X1	72,419
10 x1	20	90	7,0	1	1028610X1	80,637
10 x1,25	24	100	7,0	1	1028610X125	80,637
12 x1	22	100	9,0	1	1028612X1	112,587
12 x1,25	22	100	9,0	1	1028612X125	112,587
12 x1,5	22	100	9,0	1	1028612X15	112,587
14 x1	22	100	11,0	1	1028614X1	136,931
14 x1,25	22	100	11,0	1	1028614X125	136,931
14 x1,5	22	100	11,0	1	1028614X15	136,931
16 x1	22	100	12,0	1	1028616X1	158,841
16 x1,5	22	100	12,0	1	1028616X15	158,841
18 x1	25	110	14,0	1	1028618X1	190,181
18 x1,5	25	110	14,0	1	1028618X15	190,181
18 x2	34	125	14,0	1	1028618X2	190,181
20 x1	25	125	16,0	1	1028620X1	208,439
20 x1,25	25	125	16,0	1	1028620X125	208,439
20 x1,5	25	125	16,0	1	1028620X15	208,439
20 x2	34	140	16,0	1	1028620X2	208,439
22 x1	25	125	18,0	1	1028622X1	261,689
22 x1,5	25	125	18,0	1	1028622X15	261,689

d <sub>1</sub>	l <sub>2</sub>	l <sub>1</sub>	d <sub>2</sub>	pcs	cod.	€ cad/each
M 22 x2	34	140	18,0	1	1028622X2	261,689
24 x1	28	140	18,0	1	1028624X1	305,811
24 x1,5	28	140	18,0	1	1028624X15	305,811
24 x2	28	140	18,0	1	1028624X2	305,811
25 x1	28	140	18,0	1	1028625X1	305,811
26 x1,5	28	140	18,0	1	1028626X15	305,811
27 x1,5	28	140	20,0	1	1028627X15	383,405
27 x2	28	140	20,0	1	1028627X2	383,405
28 x1,5	28	140	20,0	1	1028628X15	383,405
30 x1,5	28	150	22,0	1	1028630X15	438,178
30 x2	28	150	22,0	1	1028630X2	438,178
32 x1,5	28	150	22,0	1	1028632X15	541,636
32 x2	28	150	22,0	1	1028632X2	541,636
33 x2	30	160	25,0	1	1028633X2	541,636
35 x1,5	30	170	28,0	1	1028635X15	541,636
36 x1,5	30	170	28,0	1	1028636X15	678,567
36 x2	30	170	28,0	1	1028636X2	678,567
38 x1,5	30	170	28,0	1	1028638X15	718,124
40 x1,5	30	170	32,0	1	1028640X15	782,025
42 x1,5	30	170	32,0	1	1028642X15	873,312
45 x1,5	32	180	36,0	1	1028645X15	1034,586
48 x1,5	32	190	36,0	1	1028648X15	1247,589
50 x1,5	32	190	36,0	1	1028650X15	1445,378
52 x1,5	32	190	40,0	1	1028652X15	1597,523

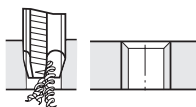

Per fori in acciai con R<sub>s</sub> 850 N/mm<sup>2</sup> ghisa malleabile, metalli non ferrosi a truciolo lungo, acciai resistenti al calore, acciai inox. For holes in steel with R<sub>s</sub> 850 N/mm<sup>2</sup> malleable cast iron, non ferrous metal with long chips, stainless steel, heat resistant steel. / Pour trous en acier avec R<sub>s</sub> 850 N/mm<sup>2</sup> fonte, alliages légers, acier inoxydable. / Para orificios in acero de hasta R<sub>s</sub> 850 N/mm<sup>2</sup> aleaciones ligeras, fundicion, acero aleado y acero inox. / Für grundloch in Stahl mit R<sub>s</sub> 850 N/mm<sup>2</sup>, Stahlguss, alu langspanend, korrosions-beständige Stähle (V2A-V4A) etc.

# 10287

## Maschi a macchina "sinistri", filettatura metrica ISO a passo fine

Machine taps, "left hand", metric thread / T Tarauds machine, "gauche", filetage métrique

Machos de maquina, "izquierda", rosca metrica / Maschinengewindebohrer, "linksgewinde", für metrisches ISO.

HSS  
CO5

DIN  
374/C  
35°



ISO2  
6H

MF

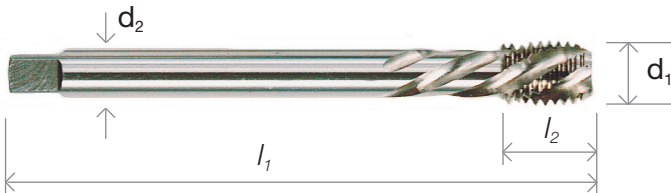
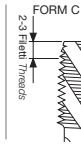

d <sub>1</sub>	l <sub>2</sub>	l <sub>1</sub>	d <sub>2</sub>	pcs	cod.	€ cad/each
M 4 x0,35	10	63	2,8	1	1028704x035	80,637
5 x0,5	12	70	3,5	1	1028705x05	80,637
6 x0,75	14	80	4,5	1	1028706x075	80,637
8 x0,75	19	80	6,0	1	1028708x075	80,637
8 x1	22	90	6,0	1	1028708x1	80,637
10 x1	20	90	7,0	1	1028710x1	97,373
10 x1,25	24	100	7,0	1	1028710x125	97,373
12 x1	22	100	9,0	1	1028712x1	124,759
12 x1,25	22	100	9,0	1	1028712x125	124,759
12 x1,5	22	100	9,0	1	1028712x15	124,759
14 x1	22	100	11,0	1	1028714x1	152,145
14 x1,25	22	100	11,0	1	1028714x125	152,145
14 x1,5	22	100	11,0	1	1028714x15	152,145
16 x1	22	100	12,0	1	1028716x1	174,967
16 x1,5	22	100	12,0	1	1028716x15	174,967
18 x1	25	110	14,0	1	1028718x1	216,046
18 x1,5	25	110	14,0	1	1028718x15	216,046
18 x2	34	125	14,0	1	1028718x2	216,046
20 x1	25	125	16,0	1	1028720x1	241,911
20 x1,25	25	125	16,0	1	1028720x125	241,911
20 x1,5	25	125	16,0	1	1028720x15	241,911
20 x2	34	140	16,0	1	1028720x2	241,911
22 x1	25	125	18,0	1	1028722x1	292,118
22 x1,5	25	125	18,0	1	1028722x15	292,118

d <sub>1</sub>	l <sub>2</sub>	l <sub>1</sub>	d <sub>2</sub>	pcs	cod.	€ cad/each
M 22 x2	34	140	18,0	1	1028722x2	292,118
24 x1	28	140	18,0	1	1028724x1	349,934
24 x1,5	28	140	18,0	1	1028724x15	349,934
24 x2	28	140	18,0	1	1028724x2	349,934
25 x1	28	140	18,0	1	1028725x1	349,934
26 x1,5	28	140	18,0	1	1028726x15	349,934
27 x1,5	28	140	20,0	1	1028727x15	422,963
27 x2	28	140	20,0	1	1028727x2	422,963
28 x1,5	28	140	20,0	1	1028728x15	422,963
30 x1,5	28	150	22,0	1	1028730x15	480,778
30 x2	28	150	22,0	1	1028730x2	480,778
32 x1,5	28	150	22,0	1	1028732x15	599,451
32 x2	28	150	22,0	1	1028732x2	599,451
33 x2	30	160	25,0	1	1028733x2	599,451
35 x1,5	30	170	28,0	1	1028735x15	599,451
36 x1,5	30	170	28,0	1	1028736x15	754,639
36 x2	30	170	28,0	1	1028736x2	754,639
38 x1,5	30	170	28,0	1	1028738x15	791,154
40 x1,5	30	170	32,0	1	1028740x15	861,141
42 x1,5	30	170	32,0	1	1028742x15	973,728
45 x1,5	32	180	36,0	1	1028745x15	1144,130
48 x1,5	32	190	36,0	1	1028748x15	1363,219
50 x1,5	32	190	36,0	1	1028750x15	1588,394
52 x1,5	32	190	40,0	1	1028752x15	1743,582

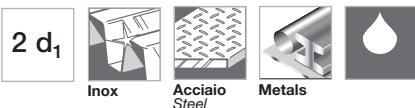
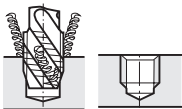

Per fori ciechi in acciai con R<sub>s</sub> 850 N/mm<sup>2</sup> ghisa malleabile, metalli non ferrosi a truciolo lungo, acciai resistenti al calore, acciai inox. For blind holes in steel with R<sub>s</sub> 850 N/mm<sup>2</sup> malleable cast iron, non ferrous metal with long chips, stainless steel, heat resistant steel. / Pour trous débouchants en acier avec R<sub>s</sub> 850 N/mm<sup>2</sup> fonte, alliages légers, acier inoxydable. / Para orificios ciegos in acero de hasta R<sub>s</sub> 850 N/mm<sup>2</sup> aleaciones ligeras, fundicion, acero aleado y acero inox. / Für durchgangsloch in Stahl mit R<sub>s</sub> 850 N/mm<sup>2</sup>, Stahlguss, alu langspanend, korrosions-beständige Stähle (V2A-V4A) etc.

# 10289

## Maschi a macchina "sinistri", filettatura GAS cilindrica BSP

Machine taps, "left hand", BSP pipe-thread / Tarauds machine, "gauche", filetage gas BSP

Machos de maquina, "izquierda", rosca gas BSP / Maschinengewindebohrer, "linksgewinde", für Rohrgewinde.

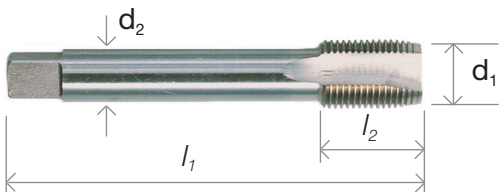

	$d_1$	$l_2$	$l_1$	$d_2$	pcs 	cod.	€ cad/each
<b>G</b>	1/8 x 28	20	90	7,0	1	102891/8	51,429
	1/4 x 19	22	100	11,0	1	102891/4	64,418
	3/8 x 19	22	100	12,0	1	102893/8	80,533
	1/2 x 14	25	125	16,0	1	102891/2	112,453
	5/8 x 14	25	125	18,0	1	102895/8	129,456
	3/4 x 14	28	140	20,0	1	102893/4	166,707
	1" x 11	30	160	25,0	1	102891"	242,997

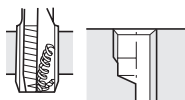

Per fori ciechi e passanti in acciai con  $R_s \leq 850 \text{ N/mm}^2$  ghisa malleabile, metalli non ferrosi a truciolo lungo, acciai resistenti al calore, acciai inox. For blind and through holes in steel with  $R_s \leq 850 \text{ N/mm}^2$  malleable cast iron, non ferrous metal with long chips, stainless steel, heat resistant steel. / Pour trous débouchants et borgnes en acier avec  $R_s \leq 850 \text{ N/mm}^2$  fonte, alliages légers, acier inoxydable. / Para orificios pasantes y ciegos in acero de hasta  $R_s \leq 850 \text{ N/mm}^2$  aleaciones ligeras, fundicion, acero aleado y acero inox. / Für grund- und durchgangslöcher in Stahl mit  $R_s \leq 850 \text{ N/mm}^2$ , Stahlguss, alu langspanend, korrosions-beständige Stähle (V2A-V4A) etc.

# MASCHI CON ANELLO COLORATO

Colored ring machine taps / Tarauds machine avec anneau coloré  
Machos de maquina con anillo pintado / Farbgring-Maschinengewindedohrer

## Guida alla scelta del maschio in funzione del materiale da lavorare Applications / Applications / Aplicaciones / Anwendung



 Utensile universale, per la filettatura di acciai con resistenza R < 900 N/mm<sup>2</sup>, materiali mediamente abrasivi, alluminio e sue leghe, acciai in genere e ghise. / Universal tool, for threading into steel R < 900 N/mm<sup>2</sup>, light abrasive materials, aluminium and its alloys, general steels and cast iron. / Outil universel pour l'affutage des aciers avec R < 900 N/mm<sup>2</sup>, matériaux abrasives, aluminium et son alliages, aciers et fer fondu. / Utensilio universal para roscar en aceros con R < 900 N/mm<sup>2</sup>, materiales abrasivos, aluminio y su aleaciones, aceros y fundicion.



 Dedicato alla filettatura di acciai inox, acciai per utensili, acciai resistenti al calore, acciai legati in genere, bronzo a truciolo lungo, rame con R < 1000 N/mm<sup>2</sup>. / For making threads in stainless steel, heat resistant steel, structural steel, long chipping bronze, copper with R < 1000 N/mm<sup>2</sup>. / Pour taraudage en acier inoxydable, acier pour traitement thermique, acier allié avec R < 1000 N/mm<sup>2</sup>. / Para roscar acero inoxidable, acero aleado, bronce. / Für VA-Werkstoffe, hitzbeständige Stähle, Messing, Alu.



 Speciale per acciai resistenti all'usura come acciai refrattari, acciai legati da tempra e cementazione, acciai per utensili con R < 1200 N/mm<sup>2</sup>. \* For use in wear resistant steel, heat resistant steel, tool steel with R < 1200 N/mm<sup>2</sup>. / Pour taraudage en aciers refractaires, acier de outil, acier pour traitement thermique avec R < 1200 N/mm<sup>2</sup>. / Para rosca en acero resistente al calor, acero para tratamiento termico, acero para utensilios hasta R < 1200 N/mm<sup>2</sup>. / Für Gewindebohrer in hochlegierte Stähle, zähe kurzspanende Werkstoffe, legierte Werkzeugstähle.



 Speciale per ghisa grigia e sferoidale, leghe di magnesio, bronzo e alluminio a truciolo corto, plastica dura. / For making threads into through and blind holes, cast iron, magnesium alloys, bronze and short chip aluminium, hard plastics. / Pour taraudage en fontes à haute résistance, alloages de magnésium, bronce, plastique très dur. / Para roscar fundiciones, aleaciones de magnesio, bronce, plastico duro. / Für Grauguss and Sphäroguss, Magnesiumlegierungen, Bronze und Alu-Kurzspanend.



 Dedicato alle lavorazioni di alluminio e materiali a truciolo lungo. / For aluminium and long chip materials. / Pour aluminium et alliage léger. / Para aluminium y aleaciones ligeras. / Für Aluminium und Leichtmetallegerung.



 Speciale per ottone e materiali a truciolo corto. / For brass and short chip materials. / Pour laiton. / Para laton. / Für Messing.



 Speciale con imbocco molto lungo (Form A) per acciai resistenti all'usura come acciai refrattari, acciai legati da tempra e cementazione, acciai per utensili con R < 1200 N/mm<sup>2</sup>. / For use in wear resistant steel, heat resistant steel, tool steel with R < 1200 N/mm<sup>2</sup>. / Pour taraudage en aciers refractaires, acier de outil, acier pour traitement thermique avec R < 1200 N/mm<sup>2</sup>. / Para rosca en acero resistente al calor, acero para tratamiento termico, acero para utensilios hasta R < 1200 N/mm<sup>2</sup>. / Für Gewindebohrer in hochlegierte Stähle, zähe kurzspanende Werkstoffe, legierte Werkzeugstähle.

## 10515

### Maschi a macchina **universali**, filettatura metrica ISO a passo grosso

Universal machine taps, metric thread / Tarauds machine, fil. Metrique

Machos de maquina, rosca metrica / Maschinen-Gewindebohrer für metrisches ISO-Regelgewinde

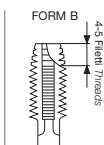
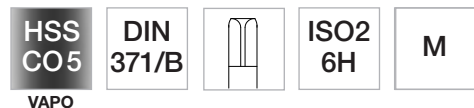

### SUPER POWER TAPS

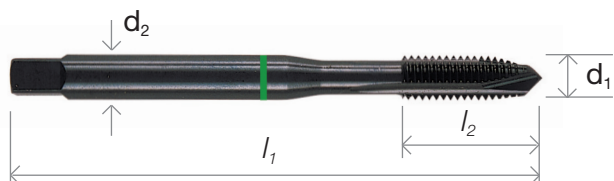

$d_1$	$l_2$	$l_1$	$d_2$	pcs	cod.	€ cad/each
M 3 x 0,5	11	56	3,5	1	1051503X05	24,944
4 x 0,7	13	63	4,5	1	1051504X07	25,358
5 x 0,8	16	70	6,0	1	1051505X08	25,358
6 x 1	19	80	6,0	1	1051506X1	25,823
8 x 1,25	22	90	8,0	1	1051508X125	29,912
10 x 1,5	24	100	10,0	1	1051510X15	35,759

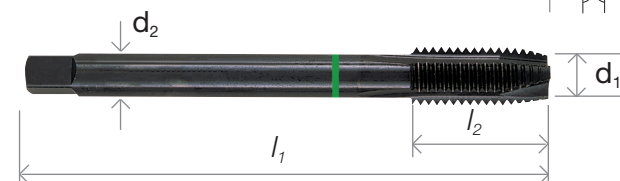
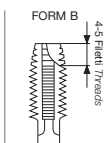
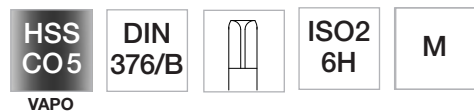

$d_1$	$l_2$	$l_1$	$d_2$	pcs	cod.	€ cad/each
M 12 x 1,75	29	110	9,0	1	1051512X175	45,281
14 x 2	30	110	11,0	1	1051514X2	66,809
16 x 2	30	110	12,0	1	1051516X2	66,809
20 x 2,5	34	140	16,0	1	1051520X25	16,398

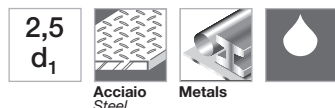

I maschi con anello verde hanno un alto rendimento nella filettatura di acciai con resistenza  $R < 900 \text{ N/mm}^2$ , materiali mediamente abrasivi, alluminio e sue leghe, acciai in genere e ghise. Il trattamento superficiale di vaporizzazione aumenta la durezza superficiale e la resistenza a usura del maschio. Green ring machine taps are useful when threading steel with  $R < 900 \text{ N/mm}^2$ , light abrasive materials, aluminium and its alloys, general steels and cast iron. The steam tempering of the tap increases hardness and wear resistance.

# 10516

## Maschi a macchina **universali**, filettatura metrica ISO a passo grosso

Universal machine taps, metric thread / Tarauds machine, fil. Metrique

Machos de maquina, rosca metrica / Maschinen-Gewindebohrer für metrisches ISO-Regelgewinde

**HSS CO5**  
**VAPO**

**DIN 371/C**  
**40°**



**ISO2 6H**

**M**

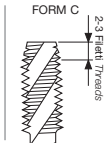

### SUPER POWER TAPS

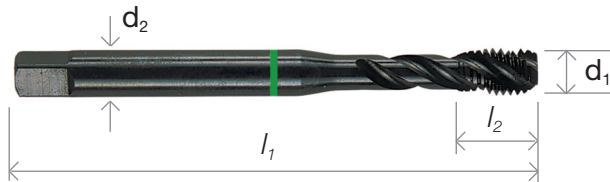

$d_1$	$l_2$	$l_1$	$d_2$	pcs	cod.	€ cad/each
<b>M 3 x 0,5</b>	6	56	3,5	1	1051603X05	26,289
<b>4 x 0,7</b>	7	63	4,5	1	1051604X07	26,289
<b>5 x 0,8</b>	8	70	6,0	1	1051605X08	27,635
<b>6 x 1</b>	10	80	6,0	1	1051606X1	28,514
<b>8 x 1,25</b>	14	90	8,0	1	1051608X125	33,534
<b>10 x 1,5</b>	16	100	10,0	1	1051610X15	38,502

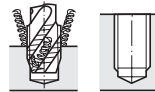

**HSS CO5**  
**VAPO**

**DIN 376/C**  
**40°**



**ISO2 6H**

**M**

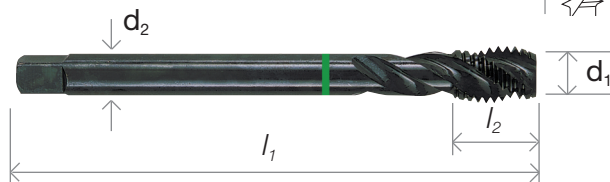
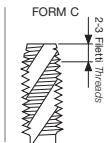

$d_1$	$l_2$	$l_1$	$d_2$	pcs	cod.	€ cad/each
<b>M 12 x 1,75</b>	18,5	110	9,0	1	1051612X175	43,936
<b>16 x 2</b>	20	110	12,0	1	1051616X2	64,584
<b>20 x 2,5</b>	25	140	16,0	1	1051620X25	97,394

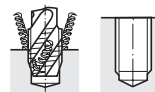

**2 d<sub>1</sub>**

**Acciaio Steel**   **Metals**

I maschi con anello verde hanno un alto rendimento nella filettatura di acciai con resistenza  $R < 900 \text{ N/mm}^2$ , materiali mediamente abrasivi, alluminio e sue leghe, acciai in genere e ghise. Il trattamento superficiale di vaporizzazione aumenta la durezza superficiale e la resistenza a usura del maschio. Green ring machine taps are useful when threading steel with  $R < 900 \text{ N/mm}^2$ , light abrasive materials, aluminium and its alloys, general steels and cast iron. The steam tempering of the tap increases hardness and wear resistance.

## 10362

### Maschi a macchina **universali**, filettatura metrica ISO a passo grosso

Universal machine taps, metric thread / Tarauds machine, fil. Metrique

Machos de maquina, rosca metrica / Maschinen-Gewindebohrer für metrisches ISO-Regelgewinde

**HSS  
CO5**  
PM

**DIN  
371/B**



**ISO2  
6H**

**M**

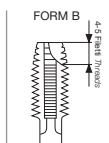

**TiN**  
HV 0,05  
2300



**SUPER POWER TAPS**  
**METALLURGIA DELLE POLVERI**  
POWDER METALLURGY

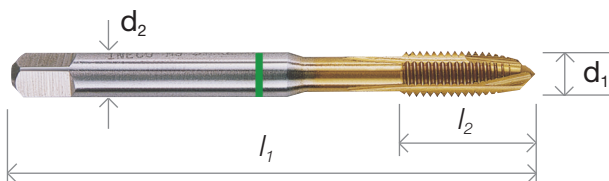

	d <sub>1</sub>	l <sub>2</sub>	l <sub>1</sub>	d <sub>2</sub>	pcs	cod.	€ cad/each
<b>M</b>	2 x 0,4	8	45	2,8	1	1036202X04	31,257
	3 x 0,5	11	56	3,5	1	1036203X05	38,916
	4 x 0,7	13	63	4,5	1	1036204X07	38,916
	5 x 0,8	16	70	6	1	1036205X08	39,848
	6 x 1	19	80	6	1	1036206X1	47,558
	8 x 1,25	22	90	8	1	1036208X125	53,251
	10 x 1,5	24	100	10	1	1036210X15	70,173



**HSS  
CO5**  
PM

**DIN  
376/B**



**ISO2  
6H**

**M**

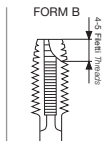

**TiN**  
HV 0,05  
2300

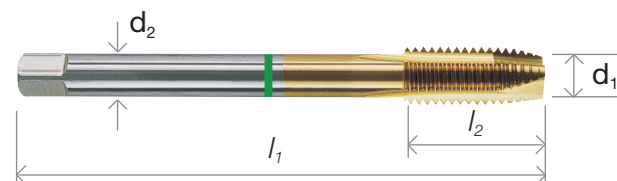

	d <sub>1</sub>	l <sub>2</sub>	l <sub>1</sub>	d <sub>2</sub>	pcs	cod.	€ cad/each
<b>M</b>	12 x 1,75	18	110	9	1	1036212X175	83,732
	14 x 2	20	110	11	1	1036214X2	126,788
	16 x 2	22	110	12	1	1036216X2	126,788
	18 x 2,5	25	125	14	1	1036218X25	206,069
	20 x 2,5	25	140	16	1	1036220X25	212,696

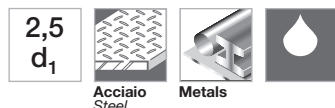

I maschi con anello verde hanno un alto rendimento nella filettatura di acciai ad alta resistenza ( $R < 1200 \text{ N/mm}^2$ ), acciai inox e resistenti agli acidi, alluminio e sue leghe, acciai in genere e ghise. Sono realizzati con la metallurgia delle polveri, per garantire la massima omogeneità di struttura dell'acciaio superrapido HSS-Co. Green ring machine taps are useful when threading high-tensile steel ( $R < 1200 \text{ N/mm}^2$ ), stainless steel, acid-resistance steel, aluminium and its alloys, general steels and cast iron. They're made by powder metallurgy to assure the best homogeneous structure of HSS-CO steel.

# 10363

## Maschi a macchina **universali**, filettatura metrica ISO a passo grosso

Universal machine taps, metric thread / Tarauds machine, fil. Metrique

Machos de maquina, rosca metrica / Maschinen-Gewindebohrer für metrisches ISO-Regelgewinde



### SUPER POWER TAPS

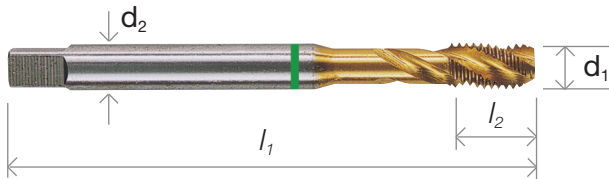

	d <sub>1</sub>	l <sub>2</sub>	l <sub>1</sub>	d <sub>2</sub>	pcs	cod.	€ cad/each
<b>M</b>	2 x 0,4	6	45	2,8	1	1036302X04	28,980
	3 x 0,5	6	56	3,5	1	1036303X05	33,534
	4 x 0,7	7	63	4,5	1	1036304X07	35,759
	5 x 0,8	8	70	6	1	1036305X08	36,225
	6 x 1	10	80	6	1	1036306X1	45,281
	8 x 1,25	14	90	8	1	1036308X125	48,749
	10 x 1,5	16	100	10	1	1036310X15	62,307

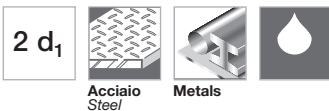
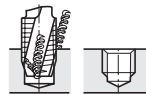

### Metallurgia delle polveri / Powder metallurgy

L'acciaio superrapido derivato dal processo di metallurgia delle polveri offre prestazioni eccezionali: presenta una elevata durezza a caldo e una elevata tenacità, garantita dall'alto contenuto di elementi di lega e dalla microstruttura fortemente omogenea. Gli utensili prodotti con la metallurgia delle polveri (Powder Metallurgy) hanno una durata più elevata ed un rendimento più alto, oltre che una finitura superficiale ottima, che agevola lo scorrimento dei trucioli di lavorazione lontano dalla zona di taglio.

HSS made by powder metallurgy has excellent performances: its homogeneous structure assures high toughness and high resistance. The finishing of the tools are really smooth, so the chip can easily be evacuated far from the cutting zone, thus avoiding built-up edge growth.

L'acier super rapide, issu du procédé de métallurgie des poudres, offre des performances exceptionnelles : il présente une dureté à chaud élevée et une haute ténacité, garantie par la forte teneur en éléments d'alliage et par la microstructure très homogène.

Les outils fabriqués avec la métallurgie des poudres (Powder Metallurgy) ont une durée et un rendement plus élevés ainsi qu'une excellente finition de surface, ce qui facilite le glissement des copeaux d'usinage hors de la zone de découpe.

El acero super-rápido derivado del proceso de metalurgia de los polvos ofrece unas prestaciones excepcionales; presenta una elevada dureza en caliente y una elevada tenacidad, garantizada por el alto contenido de elementos de aleación y por la micro-estructura altamente homogénea.

Los utensilios producidos con la metalurgia de los polvos (Powder Metallurgy) tienen una duración más extensa y un rendimiento más elevado, además de un óptimo acabado superficial, que facilita el deslizamiento de las rebabas del trabajo lejos de la zona de corte.

Der Hochleistungs-Schnellstahl aus dem Verfahren der Pulvermetallurgie bietet außergewöhnliche Leistungen: er verfügt über eine hohe Hitzebeständigkeit und eine hohe Zähigkeit, die durch den hohen Gehalt an Legierungselementen und die äußerst homogene Mikrostruktur garantiert ist.

Die mit der Pulvermetallurgie (Powder Metallurgy) hergestellten Werkzeuge besitzen eine höhere Haltbarkeit und eine höhere Arbeitsleistung. Zudem bieten sie eine hervorragende Oberflächengüte, die das Gleiten der Späne aus dem Schneidbereich erleichtert.



## 10504

### Maschi a macchina con anello per utilizzi speciali, anello bianco

White ring machine taps / Tarauds machine avec anneau blanc

Machos de maquina con anillo blanco / Weissring-Maschinengewindebohrer

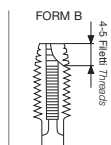

Speciale acciaio inox  
Special for Stainless steel



	$d_1$	$l_2$	$l_1$	$d_2$	pcs 	cod.	€ cad/each
<b>M 3</b> x 0,5		11	56	3,5	1	1050403X05	22,190
<b>4</b> x 0,7		13	63	4,5	1	1050404X07	22,190
<b>5</b> x 0,8		16	70	6,0	1	1050405X08	23,867
<b>6</b> x 1		19	80	6,0	1	1050406X1	23,871
<b>8</b> x 1,25		22	90	8,0	1	1050408X125	27,500
<b>10</b> x 1,5		24	100	10,0	1	1050410X15	33,286



Finitura: Ossidazione in vapore di  $Fe_3O_4$  che aumenta la durezza superficiale e la resistenza a usura riducendo la tendenza all'incollamento dei trucioli.  
Finish: Steam Tempered of  $Fe_3O_4$ , increasing surface hardness and wear resistance.

## 10505

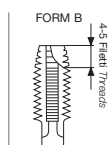

Speciale acciaio inox  
Special for Stainless steel



	$d_1$	$l_2$	$l_1$	$d_2$	pcs 	cod.	€ cad/each
<b>M 12</b> x 1,75		29	110	9,0	1	1050512X175	40,034
<b>14</b> x 2		30	110	11,0	1	1050514X2	51,367
<b>16</b> x 2		30	110	12,0	1	1050516X2	58,353
<b>18</b> x 2,5		34	125	14,0	1	1050518X25	80,068
<b>20</b> x 2,5		34	140	16,0	1	1050520X25	111,904



Finitura: Ossidazione in vapore di  $Fe_3O_4$  che aumenta la durezza superficiale e la resistenza a usura riducendo la tendenza all'incollamento dei trucioli.  
Finish: Steam Tempered of  $Fe_3O_4$ , increasing surface hardness and wear resistance.



Per filettature in acciaio inox, acciai per utensili, acciai resistenti al calore, acciai legati in genere, bronzo a truciolo lungo, rame con  $R_s \leq 1000$  N/mm<sup>2</sup>. For making threads in stainless steel, heat resistant steel, structural steel, long chipping bronze, copper with  $R_s \leq 1000$  N/mm<sup>2</sup>. Pour taraudage en acier inoxydable, acier pour traitement thermique, acier allié avec  $R_s \leq 1000$  N/mm<sup>2</sup>. Para roscar acero inoxidable, acero aleado, bronce. Für VA-Werkstoffe, hitzbeständige Stähle, Messing, Alu.



7 pcs - M 3÷12

10520300

€ 179,117

# 10506

## Maschi a macchina con anello per utilizzi speciali, anello bianco

White ring machine taps / Tarauds machine avec anneau blanc

Machos de maquina con anillo blanco / Weissring-Maschinengewindebohrer

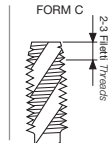
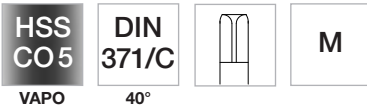

**Speciale acciaio inox**  
Special for Stainless steel

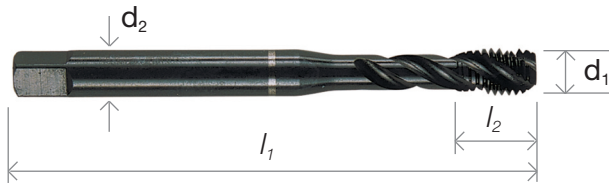

d <sub>1</sub>	l <sub>2</sub>	l <sub>1</sub>	d <sub>2</sub>	pcs	cod.	€ cad/each
<b>M 3</b> x 0,5	6	56	3,5	1	1050603X05	28,287
<b>4</b> x 0,7	7	63	4,5	1	1050604X07	28,287
<b>5</b> x 0,8	8	70	6,0	1	1050605X08	30,294
<b>6</b> x 1	10	80	6,0	1	1050606X1	29,994
<b>8</b> x 1,25	14	90	8,0	1	1050608X125	35,097
<b>10</b> x 1,5	16	100	10,0	1	1050610X15	41,866

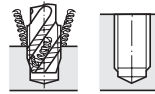

# 10507

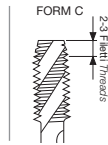
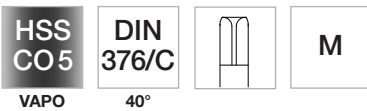

**Speciale acciaio inox**  
Special for Stainless steel

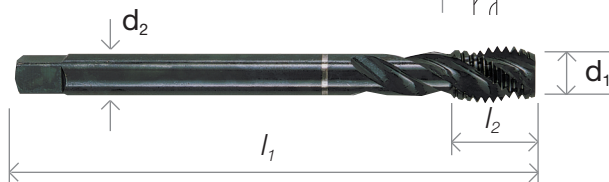

d <sub>1</sub>	l <sub>2</sub>	l <sub>1</sub>	d <sub>2</sub>	pcs	cod.	€ cad/each
<b>M 12</b> x 1,75	18	110	9,0	1	1050712X175	51,874
<b>14</b> x 2	20	110	11,0	1	1050714X2	65,733
<b>16</b> x 2	22	110	12,0	1	1050716X2	79,985
<b>18</b> x 2,5	25	125	14,0	1	1050718X25	105,125
<b>20</b> x 2,5	25	140	16,0	1	1050720X25	145,304

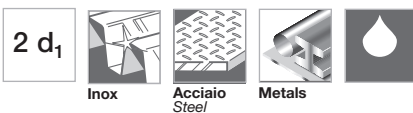
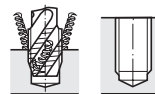

7 pcs - M 3÷12

10520301

€ 221,656

Per filettature in acciaio inox, acciai per utensili, acciai resistenti al calore, acciai legati in genere, bronzo a truciolo lungo, rame con  $R_s \leq 1000$  N/mm<sup>2</sup>. For making threads in stainless steel, heat resistant steel, structural steel, long chipping bronze, copper with  $R_s \leq 1000$  N/mm<sup>2</sup>. Pour taraudage en acier inoxydable, acier pour traitement thermique, acier allié avec  $R_s \leq 1000$  N/mm<sup>2</sup>. / Para roscar acero inoxidable, acero aleado, bronce. / Für VA-Werkstoffe, hitzbeständige Stähle, Messing, Alu.

## 10500

### Maschi a macchina con anello blu, filettatura metrica ISO

Blue ring machine taps / Tarauds machine avec anneau blue

Machos de maquina con anillo azul / Blauring-Maschinen-Gewindebohrer

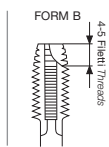

Speciali per acciai refrattari, acciai da tempra e cementazione  
Special for wear and heat resistant steel

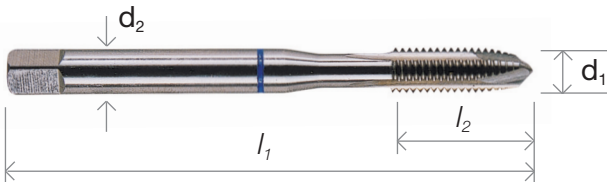

	d <sub>1</sub>	l <sub>2</sub>	l <sub>1</sub>	d <sub>2</sub>	pcs	cod.	€ cad/each
<b>M 3 x 0,5</b>		11	56	3,5	1	1050003X05	21,238
<b>4 x 0,7</b>		13	63	4,5	1	1050004X07	21,238
<b>5 x 0,8</b>		16	70	6	1	1050005X08	23,163
<b>6 x 1</b>		19	80	6	1	1050006X1	23,163
<b>8 x 1,25</b>		22	90	8	1	1050008X125	27,003
<b>10 x 1,5</b>		24	100	10	1	1050010X15	31,837



## 10501

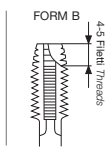

Speciali per acciai refrattari, acciai da tempra e cementazione  
Special for wear and heat resistant steel

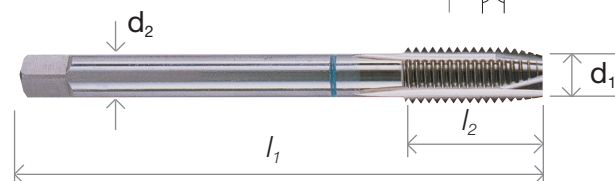

	d <sub>1</sub>	l <sub>2</sub>	l <sub>1</sub>	d <sub>2</sub>	pcs	cod.	€ cad/each
<b>M 12 x 1,75</b>		29	110	9	1	1050112X175	36,970
<b>14 x 2</b>		30	110	11	1	1050114X2	47,620
<b>16 x 2</b>		30	110	12	1	1050116X2	53,623
<b>18 x 2,5</b>		34	125	14	1	1050118X25	73,764
<b>20 x 2,5</b>		34	140	16	1	1050120X25	102,993

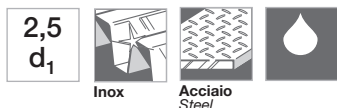

7 pcs - M 3÷12

10520302

€ 173,342

Per filettatura in acciai resistenti all'usura quali gli acciai refrattari, acciai legati da tempra e cementazione, acciai per utensili con R<sub>s</sub> 1200 N/mm<sup>2</sup>. For use in wear resistant steel, heat resistant steel, tool steel with R<sub>s</sub> 1200 N/mm<sup>2</sup> / Pour taraudage en aciers refractaires, acier de outil, acier pour traitement thermique avec R<sub>s</sub> 1200 N/mm<sup>2</sup> / Para rosca en acero resistente al calore, acero para tratamiento termico, acero para utensilios hasta R<sub>s</sub> 1200 N/mm<sup>2</sup> / Für Gewindebohrer in hochlegierte Stähle, zähe kurzspanende Werkstoffe, legierte Werkzeugstähle.

# 10502

## Maschi a macchina con anello blu, filettatura metrica ISO

Blue ring machine taps / Tarauds machine avec anneau blue

Machos de maquina con anillo azul / Blauring-Maschinen-Gewindebohrer

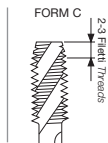
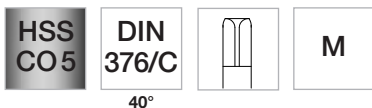

Speciali per acciai refrattari, acciai da tempra e cementazione  
Special for wear and heat resistant steel

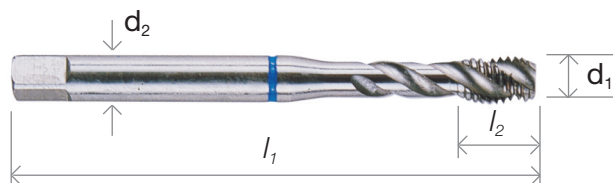

$d_1$	$l_2$	$l_1$	$d_2$	pcs	cod.	€ cad/each
M 3 x 0,5	6	56	3,5	1	1050203X05	26,972
4 x 0,7	7	63	4,5	1	1050204X07	26,972
5 x 0,8	8	70	6	1	1050205X08	29,943
6 x 1	10	80	6	1	1050206X1	31,174
8 x 1,25	14	90	8	1	1050208X125	34,052
10 x 1,5	16	100	10	1	1050210X15	39,734

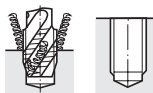

# 10503

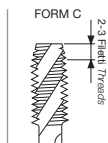
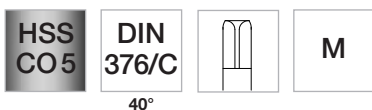

Speciali per acciai refrattari, acciai da tempra e cementazione  
Special for wear and heat resistant steel

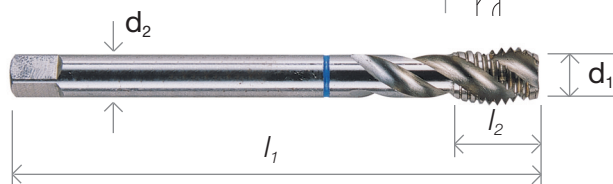

$d_1$	$l_2$	$l_1$	$d_2$	pcs	cod.	€ cad/each
M 12 x 1,75	18	110	9	1	1050312X175	47,589
14 x 2	20	110	11	1	1050314X2	60,278
16 x 2	22	110	12	1	1050316X2	73,340
18 x 2,5	25	125	14	1	1050318X25	96,503
20 x 2,5	25	140	16	1	1050320X25	137,914

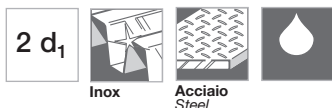
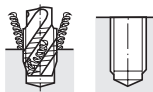

Per filettatura in acciai resistenti all'usura quali gli acciai refrattari, acciai legati da tempra e cementazione, acciai per utensili con  $R_s \leq 1200 \text{ N/mm}^2$ . For use in wear resistant steel, heat resistant steel, tool steel with  $R_s \leq 1200 \text{ N/mm}^2$  / Pour taraudage en aciers refractaires, acier de outil, acier pour traitement thermique avec  $R_s \leq 1200 \text{ N/mm}^2$  / Para rosca en acero resistente al calore, acero para tratamiento termico, acero para utensilios hasta  $R_s \leq 1200 \text{ N/mm}^2$  / Für Gewindebohrer in hochlegierte Stähle, zähe kurzspanende Werkstoffe, legierte Werkzeugstähle.



7 pcs - M 3÷12

10520303 € 215,942

## 10508

### Maschi a macchina con anello nero, filettatura metrica ISO

Black ring machine taps / Tarauds machine avec anneau noir

Machos de maquina con anillo negro / Schwarzring-Maschinengewindebohrer

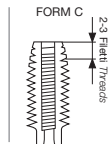

**Speciali per ghisa**  
Special for cast iron

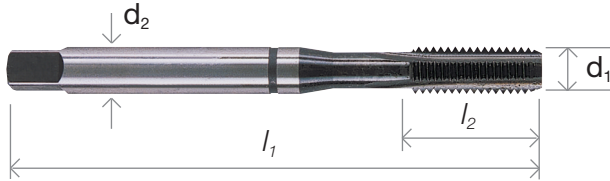

$d_1$	$l_2$	$l_1$	$d_2$	pcs	cod.	€ cad/each
<b>M 3 x 0,5</b>	11	56	3,5	1	1050803X05	22,190
<b>4 x 0,7</b>	13	63	4,5	1	1050804X07	22,190
<b>5 x 0,8</b>	16	70	6	1	1050805X08	23,867
<b>6 x 1</b>	19	80	6	1	1050806X1	23,867
<b>8 x 1,25</b>	22	90	8	1	1050808X125	27,500
<b>10 x 1,5</b>	24	100	10	1	1050810X15	33,855

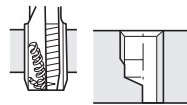

**Nitrato Nitrited**

L'arricchimento della superficie con nitrato e carbonio diminuisce la tendenza all'incollamento dei trucioli e aumenta durezza superficie e resistenza a usura.

The surface enrichment with nitrate and carbon is aimed to avoiding chips sticking on the tool and to increasing surface hardness and wear resistance.

## 10509

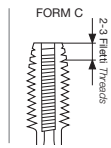

**Speciali per ghisa**  
Special for cast iron

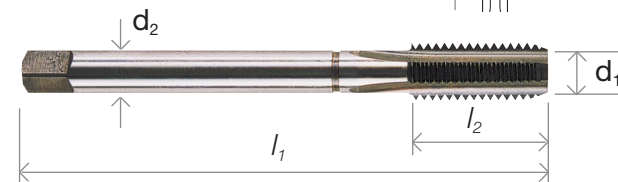

$d_1$	$l_2$	$l_1$	$d_2$	pcs	cod.	€ cad/each
<b>M 12 x 1,75</b>	29	110	9	1	1050912X175	40,034
<b>14 x 2</b>	30	110	11	1	1050914X2	51,367
<b>16 x 2</b>	30	110	12	1	1050916X2	58,353
<b>18 x 2,5</b>	34	125	14	1	1050918X25	80,068
<b>20 x 2,5</b>	34	140	16	1	1050920X25	111,904

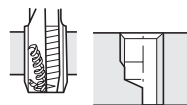

**Nitrato Nitrited**

L'arricchimento della superficie con nitrato e carbonio diminuisce la tendenza all'incollamento dei trucioli e aumenta durezza superficie e resistenza a usura.

The surface enrichment with nitrate and carbon is aimed to avoiding chips sticking on the tool and to increasing surface hardness and wear resistance.



7 pcs - M 3÷12

10520304

€ 186,600

Per filettatura in fori ciechi e passanti in ghisa grigia e sferoidale, leghe di magnesio, bronzo e alluminio a truciolo corto, plastica dura. For making threads into through and blind holes, cast iron, magnesium alloys, bronze and short chip aluminium, hard plastics. / Pour taraudage en fontes à haute résistance, alliages de magnésium, bronze, plastique très dur. / Para roscar fundiciones, aleaciones de magnesio, bronzo, plástico duro. / Für Grauguss und Sphäroguss, Magnesiumlegierungen, Bronze und Alu-Kurzspanend.

# 10511

## Maschi a macchina con anello giallo, filettatura metrica ISO

Yellow ring machine taps, ISO metric thread / Tarauds machine avec anneau jaune, filetage métrique ISO

Machos de máquina con anillo amarillo, rosca métrica ISO / Gelbring-Maschinengewindebohrer, metrisches ISO-Gewinde

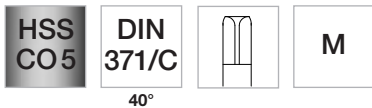

2 SPIRALI  
2 FLUTES

Speciali per alluminio  
Special for aluminium

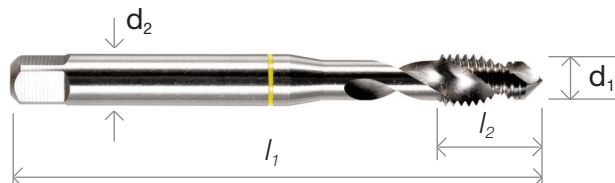

$d_1$	$l_2$	$l_1$	$d_2$	pcs	cod.	€ cad/each
M 3 x 0,5	6	56	3,5	1	1051103x05	34,848
4 x 0,7	7	63	4,5	1	1051104x07	34,848
5 x 0,8	8	70	6	1	1051105x08	37,705
6 x 1	10	80	6	1	1051106x1	37,705
8 x 1,25	14	90	8	1	1051108x125	43,325
10 x 1,5	16	100	10	1	1051110x15	52,485

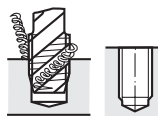

# 10512

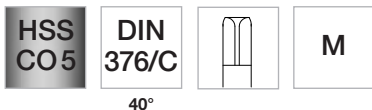

2 SPIRALI  
2 FLUTES

Speciali per alluminio  
Special for aluminium

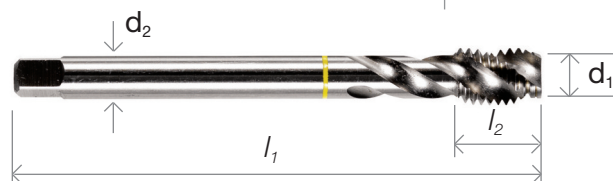

$d_1$	$l_2$	$l_1$	$d_2$	pcs	cod.	€ cad/each
M 12 x 1,75	18	110	9	1	1051212X175	63,394
14 x 2	20	110	11	1	1051214X2	83,038
16 x 2	22	110	12	1	1051216X2	94,289

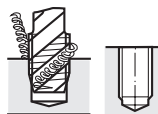

7 pcs - M 3÷12

10520305

€ 237,326

## 10513

### Maschi a macchina con anello arancio, filettatura metrica ISO

YOrange ring machine taps, ISO metric thread / Tarauds machine avec anneau orangé, filetage métrique ISO

Machos de máquina con anillo anaranjado, rosca métrica ISO / Orangering-Maschinengewindebohrer, metrisches ISO-Gewinde

HSS  
CO5

DIN  
371/C



M

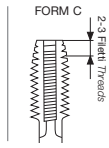

Speciali per ottone  
Special for brass

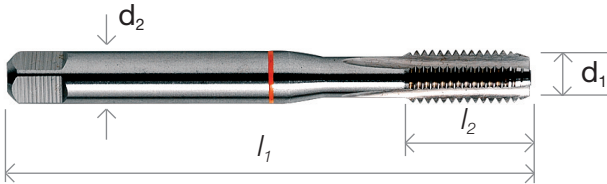

d <sub>1</sub>	l <sub>2</sub>	l <sub>1</sub>	d <sub>2</sub>	pcs	cod.	€ cad/each
M 3 x 0,5	11	56	3,5	1	1051303x05	29,891
4 x 0,7	13	63	4,5	1	1051304x07	29,891
5 x 0,8	16	70	6	1	1051305x08	32,406
6 x 1	19	80	6	1	1051306x1	32,406
8 x 1,25	22	90	8	1	1051308x125	36,939
10 x 1,5	24	100	10	1	1051310x15	44,671

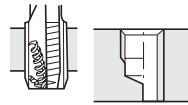

## 10514

HSS  
CO5

DIN  
376/C



M

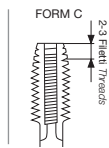

Speciali per ottone  
Special for brass

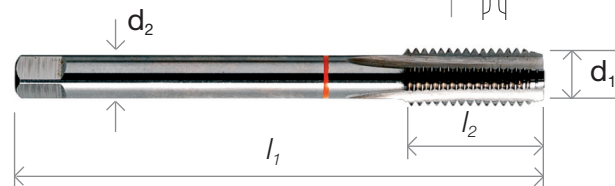

d <sub>1</sub>	l <sub>2</sub>	l <sub>1</sub>	d <sub>2</sub>	pcs	cod.	€ cad/each
M 12 x 1,75	29	110	9	1	1051412X175	54,234
14 x 2	30	110	11	1	1051414X2	69,355
16 x 2	30	110	12	1	1051416X2	79,478

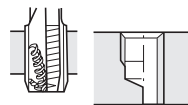

1,5  
d<sub>1</sub>

Ms

Alu



7 pcs - M 3÷12

10520306

€ 204,858

# 10510

## Maschi a macchina con anello rosso, filettatura metrica ISO

Red ring machine taps / Tarauds machine avec anneau rouge

Machos de maquina con anillo rojo / Rotring-Maschinengewindebohrer

HSS  
CO5

DIN  
371/A



M

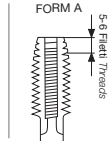

 **Speciali acciai resistenti a usura**  
Special for wear resistant steel

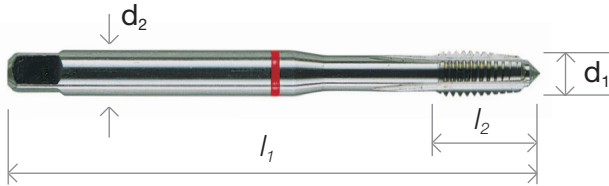

$d_1$	$l_2$	$l_1$	$d_2$	pcs 	cod.	€ cad/each
<b>M 4</b> x 0,7	9	63	4,5	1	1051004X07	<b>26,051</b>
<b>5</b> x 0,8	11	70	6	1	1051005X08	<b>28,939</b>
<b>6</b> x 1	12	80	6	1	1051006X1	<b>28,939</b>
<b>8</b> x 1,25	15	90	8	1	1051008X125	<b>31,837</b>
<b>10</b> x 1,5	16	100	10	1	1051010X15	<b>37,622</b>

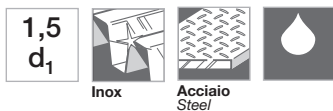
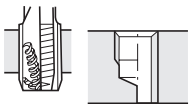

Per filettatura in acciai resistenti all'usura quali gli acciai refrattari, acciai legati da tempra e cementazione, acciai per utensili con  $R_s \leq 1200 \text{ N/mm}^2$ . For use in wear resistant steel, heat resistant steel, tool steel with  $R_s \leq 1200 \text{ N/mm}^2$  / Pour taraudage en aciers refractaires, acier de outil, acier pour traitement thermique avec  $R_s \leq 1200 \text{ N/mm}^2$  / Para rosca en acero resistente al calor, acero para tratamiento termico, acero para utensilios hasta  $R_s \leq 1200 \text{ N/mm}^2$  / Für Gewindebohrer in hochlegierte Stähle, zähe kurzspanende Werkstoffe, legierte Werkzeugstähle.



## 10100

### Maschi a mano serie di 3 pezzi, filettatura metrica ISO a passo grosso

Hand taps, 3 pcs set, metric coarse ISO thread / Jeux de 3 tarauds à main, filetage métrique ISO

Juegos de machos a mano, rosca métrica ISO / Handgewindebohrer, dreiteiliger Satz für metrisches ISO-Gewinde DIN 13

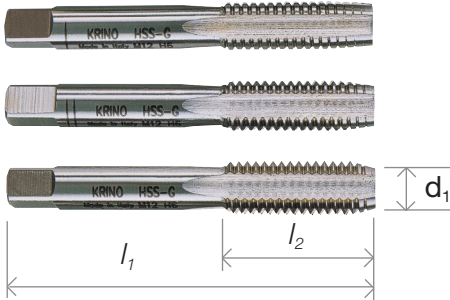
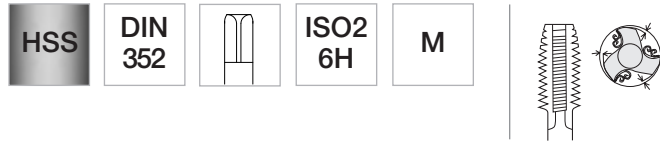

$d_1$	$l_2$	$l_1$	pcs	cod.	€ cad/each	$d_1$	$l_2$	$l_1$	pcs	cod.	€ cad/each
<b>M 1</b> x 0,25	8	32	1	1010001X025	105,228	<b>M 11</b> x 1,5	24	70	1	1010011X15	36,463
<b>1,1</b> x 0,25	8	32	1	10100011X025	105,228	<b>12</b> x 1,75	28	75	1	1010012X175	26,310
<b>1,2</b> x 0,25	8	32	1	10100012X025	105,228	<b>13</b> x 1,75	28	75	1	1010013X175	68,269
<b>1,4</b> x 0,3	10	32	1	10100014X03	105,228	<b>14</b> x 2	30	80	1	1010014X2	33,306
<b>1,6</b> x 0,35	10	32	1	10100016X035	105,228	<b>15</b> x 2	32	80	1	1010015x2	68,289
<b>1,7</b> x 0,35	10	32	1	10100017X035	105,228	<b>16</b> x 2	32	80	1	1010016X2	39,444
<b>1,8</b> x 0,35	10	32	1	10100018X035	105,228	<b>18</b> x 2,5	34	95	1	1010018X25	66,240
<b>2</b> x 0,4	10	36	1	1010002X04	18,516	<b>20</b> x 2,5	34	95	1	1010020X25	71,519
<b>2,2</b> x 0,45	11	36	1	10100022X045	24,892	<b>22</b> x 2,5	34	100	1	1010022X25	83,111
<b>2,3</b> x 0,4	11	36	1	10100023X04	24,892	<b>24</b> x 3	38	110	1	1010024X3	95,738
<b>2,5</b> x 0,45	12	40	1	10100025X045	20,669	<b>27</b> x 3	38	110	1	1010027X3	123,165
<b>2,6</b> x 0,45	12	40	1	10100026X045	21,942	<b>30</b> x 3,5	45	125	1	1010030X35	155,167
<b>3</b> x 0,5	11	40	1	1010003X05	13,165	<b>33</b> x 3,5	50	132	1	1010033X35	191,837
<b>3,5</b> x 0,6	14	45	1	10100035X06	19,075	<b>36</b> x 4	56	150	1	1010036X4	224,595
<b>4</b> x 0,7	13	45	1	1010004X07	13,817	<b>39</b> x 4	56	150	1	1010039X4	357,106
<b>4,5</b> x 0,75	16	50	1	10100045X075	24,323	<b>42</b> x 4,5	63	160	1	1010042X45	389,574
<b>5</b> x 0,8	16	50	1	1010005X08	14,366	<b>45</b> x 4,5	63	160	1	1010045X45	495,920
<b>5</b> x 1	16	56	1	1010005X1	26,672	<b>48</b> x 5	68	180	1	1010048X5	694,061
<b>5,5</b> x 0,9	18	50	1	10100055x09	38,554	<b>52</b> x 5	68	180	1	1010052X5	714,212
<b>6</b> x 1	19	56	1	1010006X1	14,697	<b>56</b> x 5,5	85	200	1	1010056X55	886,612
<b>7</b> x 1	19	56	1	1010007X1	19,924	<b>60</b> x 5,5	85	200	1	1010060X55	1123,938
<b>8</b> x 1,25	22	63	1	1010008X125	15,980	<b>64</b> x 6	90	220	1	1010064X6	1189,981
<b>9</b> x 1,25	22	63	1	1010009X125	25,803	<b>68</b> x 6	90	220	1	1010068X6	1323,196
<b>10</b> x 1,5	24	70	1	1010010X15	20,679	<b>72</b> x 6	90	240	1	1010072X6	3208,500

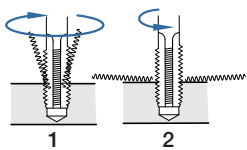

É buona norma, ad ogni rotazione del maschio<sup>(1)</sup>,  
effettuare mezzo giro indietro<sup>(2)</sup>  
per rompere il truciolo

Please rotate clockwise the tap<sup>(1)</sup> then rotate  
anticlockwise<sup>(2)</sup> to break the chip.



Per filettature in fori ciechi e passanti in acciaio da costruzione, acciai da bonifica, materiali metallici in genere sino a  $R_s \leq 800 \text{ N/mm}^2$ . For making threads in blind and through holes in structural steel, malleable cast iron, heat-treatable steel  $R_s \leq 800 \text{ N/mm}^2$  / Taraudage pour trous borgnes et débouchant des acier de construction et aciers traités  $R_s \leq 800 \text{ N/mm}^2$  / Para orificios ciegos y pasantes en materiales de hasta  $800 \text{ N/mm}^2$  / Für allgemeinen Einsatz in Baustähle, Automatenstähle und Vergütungsstähle  $R_s \leq 800 \text{ N/mm}^2$ .



7 sets / 3 pcs  
M 3-4-5-6-8-10-12

17020401 € 109,710

# 10100

## Maschio a mano **finitore**, filettatura metrica ISO a passo grosso

Bottoming hand tap, metric coarse ISO thread / Taraud à main finisseur, filetage métrique ISO

Macho a mano acabado, rosca métrica ISO / Handgewindebohrer, dreiteiliger Satz für metrisches ISO-Gewinde DIN 13

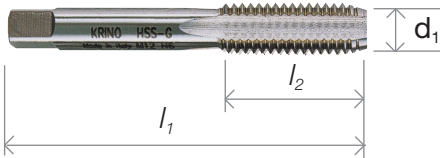
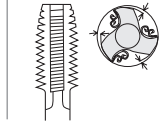
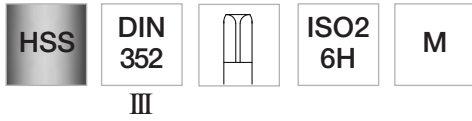

	$d_1$	$l_2$	$l_1$	pcs 	cod.	€ cad/each
<b>M</b>	3 x 0,5	12	40	1	1010003X053	4,399
	4 x 0,7	14	45	1	1010004X073	4,606
	5 x 0,8	14	50	1	1010005X083	4,782
	6 x 1	16	56	1	1010006X13	4,896
	8 x 1,25	18	63	1	1010008X1253	5,330
	10 x 1,5	25	70	1	1010010X153	6,893
	12 x 1,75	30	75	1	1010012X1753	8,766
	14 x 2	32	80	1	1010014X23	11,106
	16 x 2	32	80	1	1010016X23	13,145
	18 x 2,5	40	95	1	1010018X253	21,083
	20 x 2,5	40	95	1	1010020X253	23,805



Per filettature in fori ciechi e passanti in acciaio da costruzione, acciai da bonifica, materiali metallici in genere sino a  $R_s \leq 800$  N/mm<sup>2</sup>. For making threads in blind and through holes in structural steel, malleable cast iron, heat-treatable steel  $R_s \leq 800$  N/mm<sup>2</sup> / Taraudage pour trous borgnes et débouchant des acier de construction et aciers traités  $R_s \leq 800$  N/mm<sup>2</sup> / Para orificios ciegos y pasantes en materiales de hasta 800 N/mm<sup>2</sup> / Für allgemeinen Einsatz in Baustähle, Automatenstähle und Vergütungsstähle  $R_s \leq 800$  N/mm<sup>2</sup>.

## 10144

### Maschi a mano serie di 3 pezzi, filettatura metrica ISO a passo grosso

Hand taps, 3 pcs set, metric coarse ISO thread / Jeux de 3 tarauds à main, filetage métrique ISO

Juegos de machos a mano, rosca métrica ISO / Handgewindebohrer, dreiteiliger Satz für metrisches ISO-Gewinde DIN 13

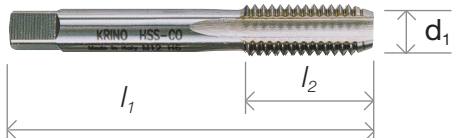
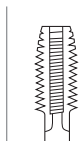
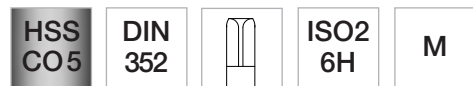

	$d_1$	$l_2$	$l_1$	pcs 	cod.	€ cad/each
<b>M</b>	3 x 0,5	11	40	1	1014403X05	20,845
	4 x 0,7	13	45	1	1014404X07	20,845
	5 x 0,8	14	50	1	1014405X08	21,569
	6 x 1	16	56	1	1014406X1	22,625
	8 x 1,25	18	63	1	1014408X125	24,912
	10 x 1,5	24	70	1	1014410X15	31,661
	12 x 1,75	29	75	1	1014412X175	40,520
	14 x 2	30	80	1	1014414X2	55,093
	16 x 2	32	80	1	1014416X2	66,499
	18 x 2,5	40	95	1	1014418X25	113,063
	20 x 2,5	40	95	1	1014420X25	120,898
	22 x 2,5	40	100	1	1014422X25	143,296
	24 x 3	50	110	1	1014424X3	161,201
	27 x 3	50	110	1	1014427X3	212,693
	30 x 3,5	56	125	1	1014430X35	270,911

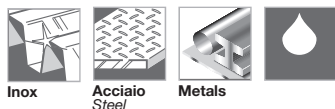

Per filettature in acciai molto duri ed abrasivi, acciai inox, acciai resistenti al calore con  $R_s \leq 1200$  N/mm<sup>2</sup>. For thread in stainless steel, heat-resistant steel, high alloy steel  $R_s \leq 1200$  N/mm<sup>2</sup> / Taraudage en acier inox et acier allié avec  $R_s \leq 1200$  N/mm<sup>2</sup> / Para acero inox y acero aleado  $R_s \leq 1200$  N/mm<sup>2</sup> / Einsatz in legierte Stähle, korrosionsbeständige Stähle, Grauguss und Stahlguss bis  $R_s \leq 1200$  N/mm<sup>2</sup>.

# 10147

## Maschi a mano serie di 3 pezzi, filettatura metrica ISO a passo grosso

Hand taps, 3 pcs set, metric coarse ISO thread / Jeux de 3 tarauds à main, filetage métrique ISO

Juegos de machos a mano, rosca métrica ISO / Handgewindebohrer, dreiteiliger Satz für metrisches ISO-Gewinde DIN 13

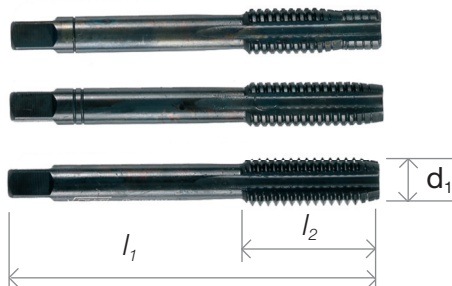
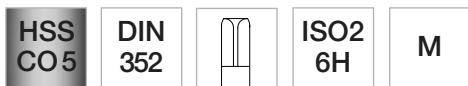

	$d_1$	$l_2$	$l_1$	pcs 	cod.	€ cad/each
<b>M</b>	3 x 0,5	11	40	1	1014703X05	61,934
	4 x 0,7	13	45	1	1014704X07	61,934
	5 x 0,8	16	50	1	1014705X08	65,816
	6 x 1	19	56	1	1014706X1	65,816
	8 x 1,25	22	63	1	1014708X125	73,578
	10 x 1,5	24	70	1	1014710X15	98,760
	12 x 1,75	29	75	1	1014712X175	132,987

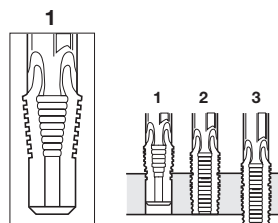

**Finitura: Ossidazione in vapore di  $Fe_3O_4$  che aumenta la durezza superficiale e la resistenza a usura riducendo la tendenza all'incollamento dei trucioli.**

Finish: Steam Tempered of  $Fe_3O_4$ , increasing surface hardness and wear resistance.

**Sbozzatore con guida**  
Taper with guide

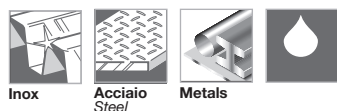

Per filettature in acciai molto duri ed abrasivi, acciai inox, acciai resistenti al calore con  $R_s \leq 1200$  N/mm<sup>2</sup>. For thread in stainless steel, heat-resistant steel, high alloy steel  $R_s \leq 1200$  N/mm<sup>2</sup> / Taraudage en acier inox et acier allié avec  $R_s \leq 1200$  N/mm<sup>2</sup> / Para acero inox y acero aleado  $R_s \leq 1200$  N/mm<sup>2</sup> / Einsatz in legierte Stähle, korrosionsbeständige Stähle, Grauguss und Stahlguss bis  $R_s \leq 1200$  N/mm<sup>2</sup>.

## 10155

### Maschi a mano al titanio serie di 3 pezzi, filettatura metrica ISO a passo grosso

Titan coated hand taps, metric coarse ISO thread / Tarauds Titan à main, filetage metrique ISO

Juegos de machos a mano de Titanio, rosca metrica ISO / Handgewindebohrer mit TiN beschichtung für metrisches ISO Regelgewinde

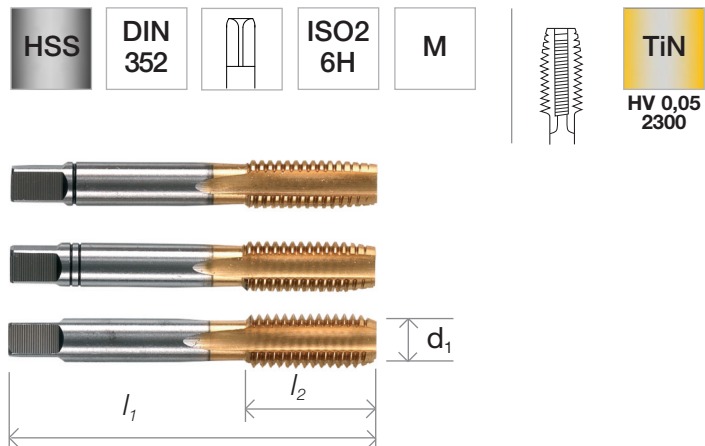

$d_1$	$l_2$	$l_1$	pcs 	cod.	€ cad/each
<b>M 3</b> x 0,5	12	40	1	1015503X05	31,754
<b>4</b> x 0,7	14	45	1	1015504X07	25,772
<b>5</b> x 0,8	16	50	1	1015505X08	26,289
<b>6</b> x 1	18	56	1	1015506X1	26,827
<b>8</b> x 1,25	22	63	1	1015508X125	41,804
<b>10</b> x 1,5	25	70	1	1015510X15	46,047
<b>12</b> x 1,75	30	75	1	1015512X175	60,278
<b>14</b> x 2	32	80	1	1015514X2	75,855
<b>16</b> x 2	32	80	1	1015516X2	82,634
<b>18</b> x 2,5	40	95	1	1015518X25	116,986
<b>20</b> x 2,5	40	95	1	1015520X25	153,925

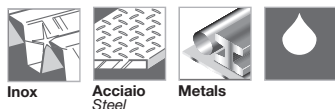

Per filettature in acciai molto duri ed abrasivi, acciai inox, acciai resistenti al calore con  $R_s \leq 1200$  N/mm<sup>2</sup>. For thread in stainless steel, heat-resistant steel, high alloy steel  $R_s \leq 1200$  N/mm<sup>2</sup> / Taraudage en acier inox et acier allié avec  $R_s \leq 1200$  N/mm<sup>2</sup> / Para acero inox y acero aleado  $R_s \leq 1200$  N/mm<sup>2</sup> / Einsatz in legierte Stähle, korrosionsbeständige Stähle, Grauguss und Stahlguss bis  $R_s \leq 1200$  N/mm<sup>2</sup>.

# 10102

## Maschi a mano **sinistri** serie di 3 pezzi, filettatura metrica ISO a passo grosso

Hand taps, 3 pcs set left hand / Jeux de 3 tarauds à main gauche

Juegos de machos a mano izquierda / Handgewindebohrer, linksgewinde dreiteiliger Satz

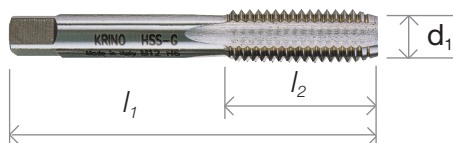
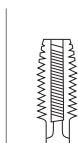

$d_1$	$l_2$	$l_1$	pcs 	cod.	€ cad/each
<b>M 3</b> x 0,5	11	40	1	1010203x05	<a href="#">20,835</a>
<b>4</b> x 0,7	13	45	1	1010204x07	<a href="#">20,835</a>
<b>5</b> x 0,8	14	50	1	1010205x08	<a href="#">21,673</a>
<b>6</b> x 1	19	56	1	1010206x1	<a href="#">22,863</a>
<b>7</b> x 1	19	56	1	1010207x1	<a href="#">30,584</a>
<b>8</b> x 1,25	22	63	1	1010208x125	<a href="#">24,664</a>
<b>10</b> x 1,5	24	70	1	1010210x15	<a href="#">31,681</a>
<b>12</b> x 1,75	28	75	1	1010212x175	<a href="#">40,634</a>
<b>14</b> x 2	30	80	1	1010214x2	<a href="#">51,419</a>
<b>16</b> x 2	32	80	1	1010216x2	<a href="#">62,172</a>
<b>18</b> x 2,5	34	95	1	1010218x25	<a href="#">106,812</a>
<b>20</b> x 2,5	34	95	1	1010220x25	<a href="#">114,616</a>
<b>22</b> x 2,5	34	100	1	1010222x25	<a href="#">135,575</a>
<b>24</b> x 3	38	110	1	1010224x3	<a href="#">155,871</a>
<b>27</b> x 3	38	110	1	1010227x3	<a href="#">200,231</a>
<b>30</b> x 3,5	45	125	1	1010230x35	<a href="#">278,136</a>
<b>33</b> x 3,5	56	125	1	1010233x35	<a href="#">634,496</a>
<b>36</b> x 4	63	150	1	1010236x4	<a href="#">739,518</a>
<b>39</b> x 4	63	150	1	1010239x4	<a href="#">954,767</a>
<b>42</b> x 4,5	63	150	1	1010242x45	<a href="#">1065,843</a>
<b>45</b> x 4,5	70	160	1	1010245x45	<a href="#">1232,033</a>
<b>48</b> x 5	75	180	1	1010248x5	<a href="#">1761,715</a>
<b>52</b> x 5	75	180	1	1010252x5	<a href="#">1863,497</a>



Acciaio  
Steel

Per filettature in fori ciechi e passanti in acciaio da costruzione, acciai da bonifica, materiali metallici in genere sino a  $R_s \leq 800$  N/mm<sup>2</sup>. For making threads in blind and through holes in structural steel, malleable cast iron, heat-treatable steel  $R_s \leq 800$  N/mm<sup>2</sup> / Taraudage pour trous borgnes et débouchant des acier de construction et aciers traités  $R_s \leq 800$  N/mm<sup>2</sup> / Para orificios ciegos y pasantes en materiales de hasta 800 N/mm<sup>2</sup> / Für allgemeinen Einsatz in Baustähle, Automatenstähle und Vergütungsstähle  $R_s \leq 800$  N/mm<sup>2</sup>.

## 10105

### Maschi a mano serie di 2 pezzi per tubi di conduzione elettrica

2 pcs hand taps for cable connection / Tarauds à main pour tubes avec armature en acier

Juegos de machos a mano para tubos de conducción eléctrica / Handgewindebohrer, zweitelliger Satz Stahlpanzer für Kabelverschraubungen

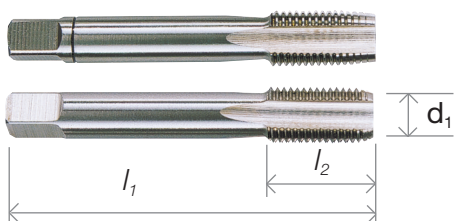
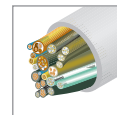
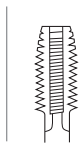
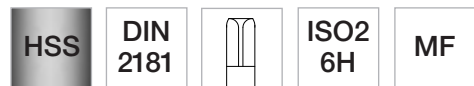

$d_1$	$l_2$	$l_1$	pcs 	cod.	€ cad/each
<b>M 12 x 1,5</b>	22	70	1	1010512x15	22,946
<b>16 x 1,5</b>	22	70	1	1010516x15	29,104
<b>20 x 1,5</b>	22	80	1	1010520x15	47,579
<b>25 x 1,5</b>	22	90	1	1010525x15	102,155
<b>32 x 1,5</b>	32	90	1	1010532x15	151,131
<b>40 x 1,5</b>	25	110	1	1010540x15	338,072
<b>50 x 1,5</b>	40	140	1	1010550x15	512,708
<b>63 x 1,5</b>	32	160	1	1010563x15	1593,434



Acciaio  
Steel

Metals

Per filettature in fori ciechi e passanti in acciaio da costruzione, acciai da bonifica, materiali metallici in genere sino a  $R_s \leq 800 \text{ N/mm}^2$ . For making threads in blind and through holes in structural steel, malleable cast iron, heat-treatable steel  $R_s \leq 800 \text{ N/mm}^2$  / Taraudage pour trous borgnes et débouchant des acier de construction et aciers traités  $R_s \leq 800 \text{ N/mm}^2$  / Para orificios ciegos y pasantes en materiales de hasta  $800 \text{ N/mm}^2$  / Für allgemeinen Einsatz in Baustähle, Automatenstähle und Vergütungsstähle  $R_s \leq 800 \text{ N/mm}^2$ .

# 10136

## Maschi a mano serie di 2 pezzi per tubi di conduzione elettrica

2 pcs hand taps for cable connection / Tarauds à main pour tubes avec armature en acier

Juegos de machos a mano para tubos de conducción eléctrica / Handgewindebohrer, zweitelliger Satz Stahlpanzer für Kabelverschraubungen

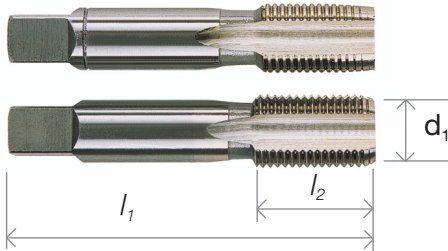
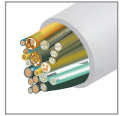
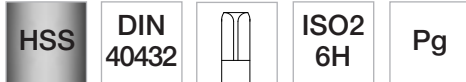

$d_1$	$l_2$	$l_1$	pcs 	cod.	€ cad/each
<b>Pg 7</b> x 20	22	70	1	1013607	54,472
<b>9</b> x 18	22	70	1	1013609	71,053
<b>11</b> x 18	22	80	1	1013611	118,663
<b>13,5</b> x 18	22	80	1	10136135	134,333
<b>16</b> x 18	22	80	1	1013616	165,600
<b>21</b> x 16	22	90	1	1013621	244,043
<b>29</b> x 16	25	100	1	1013629	367,187
<b>36</b> x 16	40	140	1	1013636	569,250
<b>42</b> x 16	40	140	1	1013642	869,400
<b>48</b> x 16	40	160	1	1013648	1001,911



Per filettature in fori ciechi e passanti in acciaio da costruzione, acciai da bonifica, materiali metallici in genere sino a  $R_s \leq 800$  N/mm<sup>2</sup>. For making threads in blind and through holes in structural steel, malleable cast iron, heat-treatable steel  $R_s \leq 800$  N/mm<sup>2</sup> / Taraudage pour trous borgnes et débouchant des acier de construction et aciers traités  $R_s \leq 800$  N/mm<sup>2</sup> / Para orificios ciegos y pasantes en materiales de hasta 800 N/mm<sup>2</sup> / Für allgemeinen Einsatz in Baustähle, Automatenstähle und Vergütungsstähle  $R_s \leq 800$  N/mm<sup>2</sup>.



## 10105

### Maschi a mano serie di 2 pezzi, filettatura metrica ISO a passo fine

Hand taps, 2 pcs set, metric fine ISO thread / Jeux de 2 tarauds à main, filetage métrique ISO à pas fin

Juegos de machos a mano, rosca métrica fina ISO / Handgewindebohrer, zweiteiliger Satz für metrisches ISO-Feingewinde

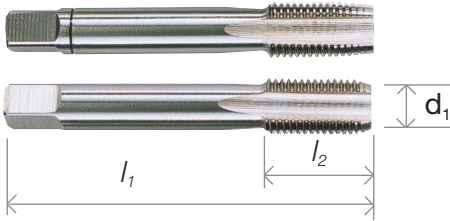
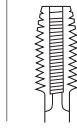
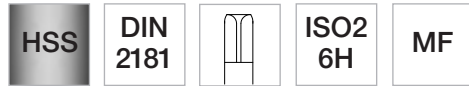

$d_1$	$l_2$	$l_1$		cod.	€ cad/each	$d_1$	$l_2$	$l_1$		cod.	€ cad/each		
M 2	x 0,25	8	36	1	1010502x025	33,751	14	x 1,25	22	70	1	1010514X125	32,126
2,2	x 0,25	9	36	1	10105022x025	33,751	14	x 1,5	22	70	1	1010514X15	27,314
2,5	x 0,35	9	40	1	10105025x035	32,468	15	x 0,75	22	70	1	1010515x075	80,150
2,6	x 0,35	9	40	1	10105026x035	32,468	15	x 1	22	70	1	1010515X1	53,737
3	x 0,35	9	40	1	1010503X035	19,085	15	x 1,5	22	70	1	1010515X15	53,737
3,5	x 0,35	10	45	1	10105035X035	19,085	16	x 0,5	22	70	1	1010516X05	80,150
4	x 0,35	10	45	1	1010504X035	21,828	16	x 0,75	22	70	1	1010516X075	80,150
4	x 0,5	10	45	1	1010504X05	15,680	16	x 1	22	70	1	1010516X1	35,821
4,5	x 0,5	12	50	1	10105045x05	32,468	16	x 1,25	22	70	1	1010516X125	33,689
5	x 0,5	12	50	1	1010505X05	16,684	16	x 1,5	22	70	1	1010516X15	29,104
5	x 0,75	12	50	1	1010505X075	35,739	17	x 1	22	70	1	1010517x1	86,754
5,5	x 0,5	12	50	1	10105055x05	32,468	17	x 1,5	22	70	1	1010517x15	86,754
6	x 0,5	14	50	1	1010506X05	32,468	18	x 0,5	22	80	1	1010518x05	86,754
6	x 0,75	14	50	1	1010506X075	17,460	18	x 0,75	22	80	1	1010518x075	86,754
7	x 0,5	14	50	1	1010507x05	32,468	18	x 1	22	80	1	1010518X1	52,609
7	x 0,75	14	50	1	1010507X075	20,731	18	x 1,25	22	80	1	1010518X125	52,609
8	x 0,5	19	50	1	1010508X05	41,690	18	x 1,5	22	80	1	1010518X15	43,097
8	x 0,75	19	50	1	1010508X075	21,218	18	x 2	22	80	1	1010518X2	54,689
8	x 1	22	56	1	1010508X1	18,247	19	x 1	22	80	1	1010519x1	109,079
9	x 0,5	19	56	1	1010509x05	35,821	19	x 1,5	22	80	1	1010519x15	109,079
9	x 0,75	19	56	1	1010509X075	30,139	20	x 0,5	22	80	1	1010520x05	109,079
9	x 1	20	63	1	1010509X1	27,873	20	x 0,75	22	80	1	1010520x075	109,079
10	x 0,5	20	63	1	1010510x05	36,380	20	x 1	22	80	1	1010520X1	72,761
10	x 0,75	20	63	1	1010510X075	28,152	20	x 1,25	22	80	1	1010520X125	66,633
10	x 1	20	63	1	1010510X1	24,178	20	x 1,5	22	80	1	1010520X15	47,579
10	x 1,25	24	70	1	1010510X125	19,924	20	x 2	22	80	1	1010520X2	58,581
11	x 0,75	20	63	1	1010511x075	46,792	21	x 1	22	80	1	1010521X1	111,894
11	x 1	20	63	1	1010511X1	28,349	21	x 1,5	22	80	1	1010521X15	111,894
11	x 1,25	22	63	1	1010511X125	30,781	22	x 0,5	22	80	1	1010522x05	129,375
12	x 0,5	22	70	1	1010512x05	46,792	22	x 0,75	22	80	1	1010522x075	111,894
12	x 0,75	22	70	1	1010512X075	28,721	22	x 1	22	80	1	1010522x1	69,262
12	x 1	22	70	1	1010512X1	28,659	22	x 1,25	22	80	1	1010522x125	69,262
12	x 1,25	22	70	1	1010512X125	22,946	22	x 1,5	22	80	1	1010522X15	69,262
12	x 1,5	22	70	1	1010512X15	22,946	22	x 2	22	80	1	1010522X2	69,262
13	x 0,5	22	70	1	1010513x05	72,202	23	x 1	22	80	1	1010523x1	151,131
13	x 0,75	22	70	1	1010513x075	72,202	23	x 1,5	22	80	1	1010523X15	91,794
13	x 1	22	70	1	1010513X1	49,618	24	x 0,5	22	90	1	1010524x05	151,131
13	x 1,5	22	70	1	1010513X15	49,618	24	x 0,75	22	90	1	1010524x075	151,131
14	x 0,5	22	70	1	1010514x05	72,202	24	x 1	22	90	1	1010524X1	72,988
14	x 0,75	22	70	1	1010514X075	34,942	24	x 1,25	22	90	1	1010524X125	65,381
14	x 1	22	70	1	1010514X1	32,126	24	x 1,5	22	90	1	1010524X15	62,131



Per filettature in fori ciechi e passanti in acciaio da costruzione, acciai da bonifica, materiali metallici in genere sino a  $R_s \leq 800$  N/mm<sup>2</sup>. For making threads in blind and through holes in structural steel, malleable cast iron, heat-treatable steel  $R_s \leq 800$  N/mm<sup>2</sup> / Taraudage pour trous borgnes et débouchant des acier de construction et aciers traités  $R_s \leq 800$  N/mm<sup>2</sup> / Para orificios ciegos y pasantes en materiales de hasta  $R_s \leq 800$  N/mm<sup>2</sup> / Für allgemeinen Einsatz in Baustähle, Automatenstähle und Vergütungsstähle  $R_s \leq 800$  N/mm<sup>2</sup>.

d <sub>1</sub>	l <sub>2</sub>	l <sub>1</sub>		cod.	€ cad/each
24 x 2	22	90	1	1010524X2	65,060
25 x 1	22	90	1	1010525X1	102,155
25 x 1,5	22	90	1	1010525X15	102,155
26 x 1	22	90	1	1010526X1	95,945
26 x 1,5	22	90	1	1010526X15	95,945
26 x 2	22	90	1	1010526X2	95,945
27 x 1	22	90	1	1010527X1	133,215
27 x 1,5	22	90	1	1010527X15	92,136
27 x 2	22	90	1	1010527X2	92,136
28 x 1	22	90	1	1010528X1	136,579
28 x 1,5	22	90	1	1010528X15	108,716
28 x 2	22	90	1	1010528X2	108,716
29 x 1,5	22	90	1	1010529X15	221,656
30 x 1	22	90	1	1010530X1	139,725
30 x 1,5	22	90	1	1010530X15	139,725
30 x 2	22	90	1	1010530X2	139,725
30 x 2,5	56	125	1	1010530X25	139,725
30 x 3	56	125	1	1010530X3	139,725
32 x 1	22	90	1	1010532x1	294,416
32 x 1,5	22	90	1	1010532X15	151,131
32 x 2	22	90	1	1010532x2	294,416
32 x 3	56	125	1	1010532X3	150,003
33 x 1,5	25	100	1	1010533X15	211,575
33 x 2	25	100	1	1010533X2	231,726
33 x 3	56	125	1	1010533X3	257,477
34 x 1	25	100	1	1010534x1	359,342
34 x 1,5	25	100	1	1010534X15	238,443
34 x 2	40	125	1	1010534X2	238,443
35 x 1	25	100	1	1010535x1	359,342
35 x 1,5	25	100	1	1010535X15	238,443
35 x 2	40	125	1	1010535x2	358,224
36 x 1	25	100	1	1010536x1	377,258
36 x 1,5	25	100	1	1010536X15	251,878
36 x 2	40	125	1	1010536X2	251,878
36 x 3	40	125	1	1010536X3	251,878
37 x 1,5	25	100	1	1010537x15	464,570
38 x 1	25	100	1	1010538x1	464,570
38 x 1,5	25	100	1	1010538X15	330,237
38 x 2	40	125	1	1010538X2	408,597
38 x 3	40	125	1	1010538x3	408,597
39 x 1,5	25	110	1	1010539X15	330,237
39 x 2	40	125	1	1010539X2	330,237
39 x 3	40	125	1	1010539X3	330,237
40 x 1	25	110	1	1010540x1	408,597
40 x 1,5	25	110	1	1010540X15	330,072
40 x 2	40	125	1	1010540X2	338,072
40 x 3	40	125	1	1010540X3	338,072
42 x 1	25	110	1	1010542x1	408,597
42 x 1,5	25	110	1	1010542X15	344,790
42 x 2	40	125	1	1010542X2	344,790
42 x 3	40	125	1	1010542X3	344,790
44 x 1,5	25	110	1	1010544x15	498,156
44 x 2	40	125	1	1010544x2	498,156
45 x 1	25	110	1	1010545x1	498,156
45 x 1,5	25	110	1	1010545X15	455,617
45 x 2	40	125	1	1010545X2	455,617
45 x 3	40	125	1	1010545X3	455,617
46 x 1,5	40	140	1	1010546x15	498,156
48 x 1	40	140	1	1010548x1	591,078
48 x 1,5	25	140	1	1010548X15	442,183
48 x 2	40	140	1	1010548X2	510,472
48 x 3	40	140	1	1010548X3	510,472
50 x 1,5	40	140	1	1010550X15	512,708
50 x 2	40	140	1	1010550X2	561,964
50 x 3	40	140	1	1010550X3	628,017
52 x 1,5	40	140	1	1010552X15	649,287
52 x 2	40	140	1	1010552X2	649,287
52 x 3	40	140	1	1010552X3	649,287
54 x 1,5	32	140	1	1010554X15	1091,025

d <sub>1</sub>	l <sub>2</sub>	l <sub>1</sub>		cod.	€ cad/each
54 x 2	36	140	1	1010554X2	1091,025
54 x 3	40	140	1	1010554X3	1091,025
54 x 4	50	180	1	1010554X4	1091,025
55 x 1,5	32	140	1	1010555X15	1258,488
55 x 2	36	140	1	1010555X2	1258,488
55 x 3	40	140	1	1010555X3	1258,488
55 x 4	50	180	1	1010555X4	1258,488
56 x 1,5	32	140	1	1010556X15	1342,229
56 x 2	36	140	1	1010556X2	1342,229
56 x 3	40	140	1	1010556X3	1342,229
56 x 4	50	180	1	1010556X4	1342,229
58 x 1,5	32	160	1	1010558X15	1375,474
58 x 2	36	160	1	1010558X2	1375,474
58 x 3	40	160	1	1010558X3	1375,474
58 x 4	55	200	1	1010558X4	1375,474
60 x 1,5	34	160	1	1010560X15	1443,204
60 x 2	36	160	1	1010560X2	1443,204
60 x 3	40	160	1	1010560X3	1443,204
60 x 4	55	200	1	1010560X4	1443,204
62 x 1,5	34	160	1	1010562X15	1560,190
62 x 2	36	160	1	1010562X2	1560,186
62 x 3	45	180	1	1010562X3	1560,186
62 x 4	55	220	1	1010562X4	1560,186
63 x 1,5	32	160	1	1010563X15	1593,434
64 x 1,5	34	160	1	1010564X15	1593,434
64 x 2	36	160	1	1010564X2	1593,434
64 x 3	45	180	1	1010564X3	1593,434
64 x 4	60	220	1	1010564X4	1593,434
65 x 1,5	34	160	1	1010565X15	1694,409
65 x 2	36	160	1	1010565X2	1694,409
65 x 3	45	180	1	1010565X3	1694,409
65 x 4	60	220	1	1010565X4	1694,409
68 x 1,5	36	160	1	1010568X15	1762,139
68 x 2	40	160	1	1010568X2	1762,139
68 x 3	50	180	1	1010568X3	1762,139
68 x 4	60	220	1	1010568X4	1762,139
70 x 1,5	36	160	1	1010570X15	2851,922
70 x 2	40	160	1	1010570X2	2851,922
70 x 3	50	200	1	1010570X3	3271,832
70 x 4	60	240	1	1010570X4	3271,832
72 x 1,5	36	160	1	1010572X15	2851,922
72 x 2	40	160	1	1010572X2	2851,922
72 x 3	50	200	1	1010572X3	3271,832
72 x 4	60	240	1	1010572X4	3271,832
74 x 1,5	36	160	1	1010574X15	3103,137
74 x 2	40	160	1	1010574X2	3103,137
74 x 3	50	200	1	1010574X3	3690,510
74 x 4	60	240	1	1010574X4	3690,510
75 x 1,5	36	160	1	1010575X15	3188,100
75 x 2	40	160	1	1010575X2	3188,100
75 x 3	50	200	1	1010575X3	3774,241
75 x 4	60	240	1	1010575X4	3774,241
76 x 1,5	36	160	1	1010576X15	3271,832
76 x 2	40	160	1	1010576X2	3271,832
76 x 3	50	220	1	1010576X3	3942,946
76 x 4	60	260	1	1010576X4	3942,946
78 x 1,5	36	160	1	1010578X15	3271,832
78 x 2	40	160	1	1010578X2	3271,832
78 x 3	55	220	1	1010578X3	3942,946
78 x 4	65	260	1	1010578X4	3942,946
80 x 1,5	36	160	1	1010580X15	3523,037
80 x 2	40	160	1	1010580X2	3523,037
80 x 3	55	220	1	1010580X3	4361,625
80 x 4	65	260	1	1010580X4	4361,625
82 x 1,5	36	160	1	1010582X15	3523,037
82 x 2	40	160	1	1010582X2	3523,037
82 x 3	55	220	1	1010582X3	4361,625
82 x 4	65	260	1	1010582X4	4361,625

d<sub>1</sub>>M82: a richiesta - on demand

## 10146

### Maschi a mano serie di 2 pezzi, filettatura metrica ISO a passo fine

Hand taps, 2 pcs set, metric fine ISO thread / Jeux de 2 tarauds à main, filetage métrique ISO à pas fin

Juego de machos a mano, rosca métrica fina ISO / Handgewindebohrer, zweiteiliger Satz für metrisches ISO-Feingewinde

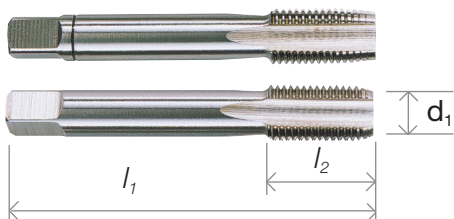
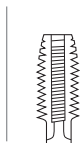
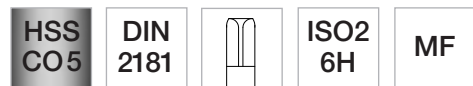

$d_1$	$l_2$	$l_1$	pcs 	cod.	€ cad/each
<b>M 6 x 0,75</b>	14	50	1	1014606x075	<b>30,201</b>
<b>8 x 0,75</b>	19	50	1	1014608x075	<b>35,511</b>
<b>8 x 1</b>	22	56	1	1014608x1	<b>30,201</b>
<b>10 x 1</b>	20	63	1	1014610x1	<b>32,240</b>
<b>10 x 1,25</b>	24	70	1	1014610x125	<b>40,044</b>
<b>12 x 1</b>	22	70	1	1014612x1	<b>37,850</b>
<b>12 x 1,25</b>	22	70	1	1014612x125	<b>48,045</b>
<b>12 x 1,5</b>	22	70	1	1014612x15	<b>36,577</b>
<b>14 x 1,25</b>	22	70	1	1014614x125	<b>52,764</b>
<b>14 x 1,5</b>	22	70	1	1014614x15	<b>45,695</b>
<b>16 x 1,5</b>	22	70	1	1014616x15	<b>48,873</b>
<b>18 x 1,5</b>	22	80	1	1014618x15	<b>63,756</b>
<b>18 x 2</b>	22	80	1	1014618x2	<b>81,703</b>
<b>20 x 1,5</b>	22	80	1	1014620x15	<b>70,121</b>
<b>20 x 2</b>	22	80	1	1014620x2	<b>87,323</b>
<b>22 x 1,5</b>	22	80	1	1014622x15	<b>89,559</b>
<b>22 x 2</b>	22	80	1	1014622x2	<b>102,993</b>
<b>24 x 1,5</b>	22	90	1	1014624x15	<b>102,993</b>

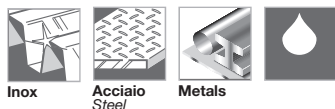

Per filettature in acciai molto duri ed abrasivi, acciai inox, acciai resistenti al calore con  $R_s \leq 1200$  N/mm<sup>2</sup>. For thread in stainless steel, heat-resistant steel, high alloy steel  $R_s \leq 1200$  N/mm<sup>2</sup> / Taraudage en acier inox et acier allié avec  $R_s \leq 1200$  N/mm<sup>2</sup> / Para acero inox y acero aleado  $R_s \leq 1200$  N/mm<sup>2</sup> / Einsatz in legierte Stähle, korrosionsbeständige Stähle, Grauguss und Stahlguss bis  $R_s \leq 1200$  N/mm<sup>2</sup>.

# 10107

## Maschi a mano serie di 2 pezzi, filettatura metrica **sinistra** a passo fine

Hand taps, metric fine ISO thread, left hand / Tarauds à main, filetage métrique ISO, gauche

Juego de machos a mano, rosca fina izquierda / Handgewindebohrer, linksgewinde, metrisches ISO-Feingewinde

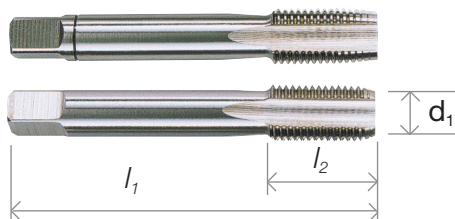
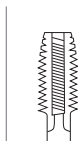

$d_1$	$l_2$	$l_1$	pcs 	cod.	€ cad/each
<b>M 6 x 0,75</b>	14	50	1	1010706x075	<b>25,006</b>
<b>8 x 0,75</b>	19	50	1	1010708x075	<b>28,825</b>
<b>8 x 1</b>	22	56	1	1010708x1	<b>25,006</b>
<b>10 x 1</b>	20	63	1	1010710x1	<b>26,744</b>
<b>10 x 1,25</b>	24	70	1	1010710x125	<b>32,644</b>
<b>12 x 1</b>	22	70	1	1010712x1	<b>31,619</b>
<b>12 x 1,25</b>	22	70	1	1010712x125	<b>40,293</b>
<b>12 x 1,5</b>	22	70	1	1010712x15	<b>30,564</b>
<b>14 x 1,25</b>	22	70	1	1010714x125	<b>43,770</b>
<b>14 x 1,5</b>	22	70	1	1010714x15	<b>38,223</b>
<b>16 x 1</b>	22	70	1	1010716x1	<b>49,256</b>
<b>16 x 1,5</b>	22	70	1	1010716x15	<b>49,256</b>
<b>18 x 1,5</b>	22	80	1	1010718x15	<b>60,341</b>
<b>20 x 1,5</b>	22	80	1	1010720x15	<b>66,685</b>
<b>22 x 1,5</b>	22	80	1	1010722x15	<b>85,750</b>
<b>24 x 1,5</b>	22	90	1	1010724x15	<b>116,427</b>
<b>24 x 2</b>	22	90	1	1010724x2	<b>181,518</b>
<b>30 x 1,5</b>	22	90	1	1010730x15	<b>388,787</b>
<b>30 x 2</b>	22	90	1	1010730x2	<b>388,787</b>



Acciaio  
Steel

Metals

Per filettature in fori ciechi e passanti in acciaio da costruzione, acciai da bonifica, materiali metallici in genere sino a  $R_s \leq 800 \text{ N/mm}^2$ . For making threads in blind and through holes in structural steel, malleable cast iron, heat-treatable steel  $R_s \leq 800 \text{ N/mm}^2$  / Taraudage pour trous borgnes et débouchant des acier de construction et aciers traités  $R_s \leq 800 \text{ N/mm}^2$  / Para orificios ciegos y pasantes en materiales de hasta  $800 \text{ N/mm}^2$  / Für allgemeinen Einsatz in Baustähle, Automatenstähle und Vergütungsstähle  $R_s \leq 800 \text{ N/mm}^2$ .

## 10115

### Maschi a mano serie di 2 pezzi, fil. gas cilindrica ISO 228 per tubi

Hand taps, 2 pcs set, Wh pipe thread ISO 228 / Jeux de 2 tarauds à main, filetages gaz de tuyauterie ISO 228

Juegos de utensilios a roscar, rosca gas cilíndrica ISO 228 / Handgewindebohrer, zweiteiliger Satz für Rohrgewinde DIN ISO 228

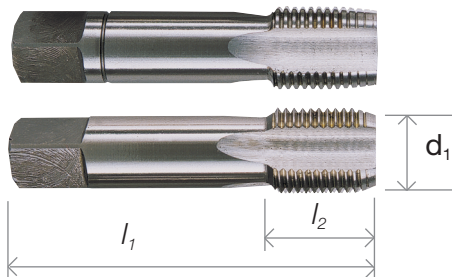
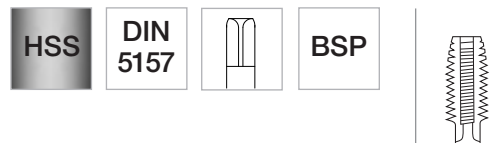

$d_1$	$l_2$	$l_1$	pcs 	cod.	€ cad/each
<b>G</b> 1/8 x 28	20	63	1	101151/8	29,601
1/4 x 19	22	70	1	101151/4	39,009
3/8 x 19	22	70	1	101153/8	48,987
1/2 x 14	22	80	1	101151/2	70,380
5/8 x 14	22	80	1	101155/8	84,860
3/4 x 14	22	90	1	101153/4	104,142
7/8 x 14	22	90	1	101157/8	135,450
1" x 11	25	100	1	101151"	164,565
1.1/8 x 11	40	125	1	101151.1/8	269,793
1.1/4 x 11	40	125	1	101151.1/4	269,793
1.3/8 x 11	40	140	1	101151.3/8	361,588
1.1/2 x 11	40	140	1	101151.1/2	361,588
1.5/8 x 11	40	140	1	101151.5/8	628,017
1.3/4 x 11	40	140	1	101151.3/4	527,260
2" x 11	40	160	1	101152"	527,260
2.1/4 x 11	40	160	1	101152.1/4	1223,567
2.1/2 x 11	40	160	1	101152.1/2	1289,610
2.3/4 x 11	40	160	1	101152.3/4	1719,487
3" x 11	40	160	1	101153"	1963,530
3.1/2 x 11	45	180	1	101153.1/2	2778,489
4" x 11	45	180	1	101154"	3175,898



Per filettature in fori ciechi e passanti in acciaio da costruzione, acciai da bonifica, materiali metallici in genere sino a  $R_s \leq 800 \text{ N/mm}^2$ . For making threads in blind and through holes in structural steel, malleable cast iron, heat-treatable steel  $R_s \leq 800 \text{ N/mm}^2$  / Taraudage pour trous borgnes et débouchant des acier de construction et aciers traités  $R_s \leq 800 \text{ N/mm}^2$  / Para orificios ciegos y pasantes en materiales de hasta  $800 \text{ N/mm}^2$  / Für allgemeinen Einsatz in Baustähle, Automatenstähle und Vergütungsstähle  $R_s \leq 800 \text{ N/mm}^2$ .

# 10148

## Maschi a mano serie di 2 pezzi, fil. gas cilindrica ISO 228 per tubi

Hand taps, 2 pcs set, Wh pipe thread ISO 228 / Jeux de 2 tarauds à main, filetages gaz de tuyauterie ISO 228

Juegos de utensilios a roscar, rosca gas cilíndrica ISO 228 / Handgewindebohrer, zweiteiliger Satz für Rohrgewinde DIN ISO 228

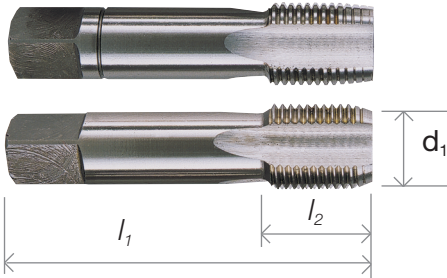
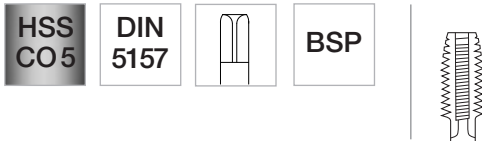

$d_1$	$l_2$	$l_1$	pcs 	cod.	€ cad/each
<b>G 1/8 x 28</b>	20	63	1	101481/8	<b>38,906</b>
<b>1/4 x 19</b>	22	70	1	101481/4	<b>51,419</b>
<b>3/8 x 19</b>	22	70	1	101483/8	<b>70,318</b>
<b>1/2 x 14</b>	22	80	1	101481/2	<b>103,438</b>
<b>3/4 x 14</b>	22	90	1	101483/4	<b>150,458</b>
<b>1" x 11</b>	25	100	1	101481"	<b>238,609</b>

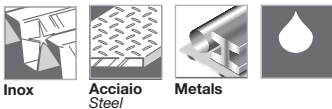

Per filettature in acciai molto duri ed abrasivi, acciai inox, acciai resistenti al calore con  $R_s \leq 1200$  N/mm<sup>2</sup>. For thread in stainless steel, heat-resistant steel, high alloy steel  $R_s \leq 1200$  N/mm<sup>2</sup> / Taraudage en acier inox et acier allié avec  $R_s \leq 1200$  N/mm<sup>2</sup> / Para acero inox y acero aleado  $R_s \leq 1200$  N/mm<sup>2</sup> / Einsatz in legierte Stähle, korrosionsbeständige Stähle, Grauguss und Stahlguss bis  $R_s \leq 1200$  N/mm<sup>2</sup>.

## 10117

### Maschi a mano serie di 2 pezzi, fil. gas cilindrica **sinistra** ISO 228 per tubi

Hand taps, 2 pcs set, Wh pipe thread ISO 228 / Jeux de 2 tarauds à main, filetages gaz de tuyauterie ISO 228

Juegos de utensilios a roscar, rosca gas cilíndrica ISO 228 / Handgewindebohrer, zweiteiliger Satz für Rohrgewinde DIN ISO 228

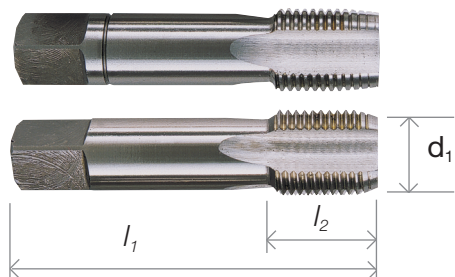

$d_1$	$l_2$	$l_1$	pcs 	cod.	€ cad/each
<b>G 1/8 x 28</b>	20	63	1	101171/8	49,380
<b>1/4 x 19</b>	22	70	1	101171/4	59,337
<b>3/8 x 19</b>	22	70	1	101173/8	74,603
<b>1/2 x 14</b>	22	80	1	101171/2	122,016
<b>5/8 x 14</b>	22	80	1	101175/8	180,401
<b>3/4 x 14</b>	22	90	1	101173/4	191,423
<b>1" x 11</b>	25	100	1	101171"	375,022
<b>1.1/8 x 11</b>	40	125	1	101171.1/8	498,218
<b>1.1/4 x 11</b>	40	125	1	101171.1/4	498,218
<b>1.3/8 x 11</b>	40	140	1	101171.3/8	667,699
<b>1.1/2 x 11</b>	40	140	1	101171.1/2	667,699
<b>1.3/4 x 11</b>	40	140	1	101171.3/4	1377,130
<b>2" x 11</b>	40	160	1	101172"	1377,130



Acciaio  
Steel

Metals

Per filettature in fori ciechi e passanti in acciaio da costruzione, acciai da bonifica, materiali metallici in genere sino a  $R_s \leq 800 \text{ N/mm}^2$ . For making threads in blind and through holes in structural steel, malleable cast iron, heat-treatable steel  $R_s \leq 800 \text{ N/mm}^2$  / Taraudage pour trous borgnes et débouchant des acier de construction et aciers traités  $R_s \leq 800 \text{ N/mm}^2$  / Para orificios ciegos y pasantes en materiales de hasta  $800 \text{ N/mm}^2$  / Für allgemeinen Einsatz in Baustähle, Automatenstähle und Vergütungsstähle  $R_s \leq 800 \text{ N/mm}^2$ .

# 10110

## Maschi a mano serie di 3 pezzi, filettatura Whitworth a passo grosso BS 84

Hand taps, 3 pcs sets, Whitworth BSW thread / Jeux de tarauds à main, filetage Whitworth

Juegos de machos a mano, rosca Whitworth / Handgewindebohrer, dreiteiliger Satz, Whitworth-Gewinde

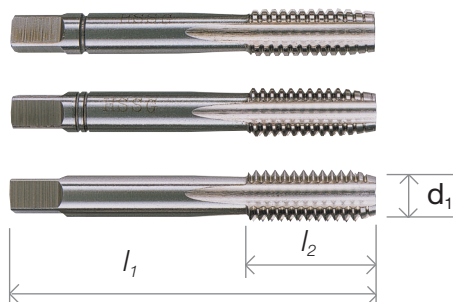
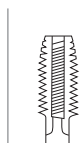
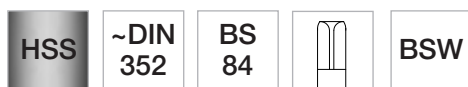

$d_1$	$l_2$	$l_1$	pcs 	cod.	€ cad/each
<b>BSW 1/16</b> x 60	10	36	1	101101/16	50,208
<b>3/32</b> x 48	10	36	1	101103/32	50,208
<b>1/8</b> x 40	12	40	1	101101/8	23,557
<b>5/32</b> x 32	14	45	1	101105/32	23,557
<b>3/16</b> x 24	18	50	1	101103/16	26,082
<b>7/32</b> x 24	18	50	1	101107/32	28,069
<b>1/4</b> x 20	19	50	1	101101/4	28,069
<b>5/16</b> x 18	22	63	1	101105/16	29,663
<b>3/8</b> x 16	24	70	1	101103/8	34,383
<b>7/16</b> x 14	24	70	1	101107/16	42,373
<b>1/2</b> x 12	29	75	1	101101/2	44,122
<b>9/16</b> x 12	30	80	1	101109/16	56,201
<b>5/8</b> x 11	32	80	1	101105/8	67,172
<b>11/16</b> x 11	32	80	1	1011011/16	113,063
<b>3/4</b> x 10	40	95	1	101103/4	113,063
<b>7/8</b> x 9	40	100	1	101107/8	136,579
<b>1"</b> x 8	50	110	1	101101"	153,366
<b>1.1/8</b> x 7	56	132	1	101101.1/8	282,100
<b>1.1/4</b> x 7	56	132	1	101101.1/4	282,100
<b>1.3/8</b> x 6	63	150	1	101101.3/8	416,443
<b>1.1/2</b> x 6	63	150	1	101101.1/2	471,287
<b>1.5/8</b> x 5	70	160	1	101101.5/8	801,535
<b>1.3/4</b> x 5	70	160	1	101101.3/4	921,316
<b>1.7/8</b> x 4.1/2	80	190	1	101101.7/8	1273,940
<b>2"</b> x 4.1/2	80	190	1	101102"	1273,940
<b>2.1/4</b> x 4	80	220	1	101102.1/4	2754,911
<b>2.1/2</b> x 4	80	220	1	101102.1/2	3543,240
<b>2.3/4</b> x 3.1/2	80	240	1	101102.3/4	9044,586
<b>3"</b> x 3.1/2	80	260	1	101103"	11655,394



Acciaio  
Steel

Metals

Per filettature in fori ciechi e passanti in acciaio da costruzione, acciai da bonifica, materiali metallici in genere sino a  $R_s \leq 800 \text{ N/mm}^2$ . For making threads in blind and through holes in structural steel, malleable cast iron, heat-treatable steel  $R_s \leq 800 \text{ N/mm}^2$  / Taraudage pour trous borgnes et débouchant des acier de construction et aciers traités  $R_s \leq 800 \text{ N/mm}^2$  / Para orificios ciegos y pasantes en materiales de hasta  $800 \text{ N/mm}^2$  / Für allgemeinen Einsatz in Baustähle, Automatenstähle und Vergütungsstähle  $R_s \leq 800 \text{ N/mm}^2$ .



## 10111

### Maschi a mano serie di 3 pezzi, filettatura Whitworth **sinistra** a passo grosso BS 84

Hand taps, 3 pcs sets, Whitworth BSW thread / Jeux de tarauds à main, filetage Whitworth

Juegos de machos a mano, rosca Whitworth / Handgewindebohrer, dreiteiliger Satz, Whitworth-Gewinde

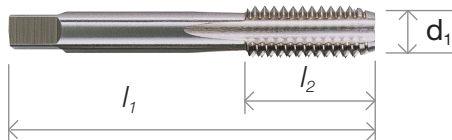
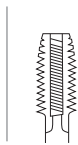

	$d_1$	$l_2$	$l_1$	pcs	cod.	€ cad/each
<b>BSW</b> 1/8 x 40	12	40	1	101111/8	55,393	
5/32 x 32	14	45	1	101115/32	55,393	
3/16 x 24	18	50	1	101113/16	55,393	
1/4 x 20	22	56	1	101111/4	55,393	
5/16 x 18	25	63	1	101115/16	57,877	
3/8 x 16	28	70	1	101113/8	65,474	
7/16 x 14	30	75	1	101117/16	80,523	
1/2 x 12	32	80	1	101111/2	94,816	
9/16 x 12	32	80	1	101119/16	125,608	
5/8 x 11	36	90	1	101115/8	140,377	
3/4 x 10	40	105	1	101113/4	188,401	
7/8 x 9	45	110	1	101117/8	231,509	
1" x 8	50	110	1	101111"	279,533	



Acciaio  
Steel

Metals

Per filettature in fori ciechi e passanti in acciaio da costruzione, acciai da bonifica, materiali metallici in genere sino a  $R_s \leq 800 \text{ N/mm}^2$ . For making threads in blind and through holes in structural steel, malleable cast iron, heat-treatable steel  $R_s \leq 800 \text{ N/mm}^2$  / Taraudage pour trous borgnes et débouchant des acier de construction et aciers traités  $R_s \leq 800 \text{ N/mm}^2$  / Para orificios ciegos y pasantes en materiales de hasta  $800 \text{ N/mm}^2$  / Für allgemeinen Einsatz in Baustähle, Automatenstähle und Vergütungsstähle  $R_s \leq 800 \text{ N/mm}^2$ .

# 10112

## Maschi a mano serie di 3 pezzi, filettatura Whitworth a passo fine BS 84

Hand taps, 3 pcs sets, Whitworth BSF thread / Jeux de tarauds à main, filetage Whitworth

Juegos de machos a mano, rosca Whitworth / Handgewindebohrer, dreiteiliger Satz, Whitworth-Gewinde

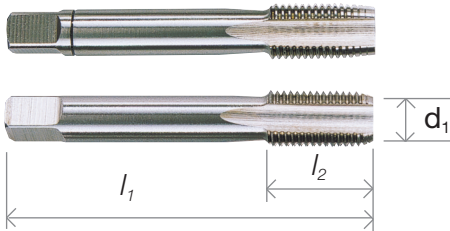
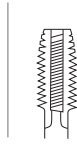
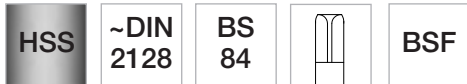

	$d_1$	$l_2$	$l_1$	pcs 	cod.	€ cad/each
<b>BSF</b>	<b>3/16 x 32</b>	14	50	1	<b>101123/16</b>	<b>18,340</b>
	<b>1/4 x 26</b>	18	50	1	<b>101121/4</b>	<b>20,151</b>
	<b>5/16 x 22</b>	22	56	1	<b>101125/16</b>	<b>21,994</b>
	<b>3/8 x 20</b>	22	63	1	<b>101123/8</b>	<b>25,637</b>
	<b>7/16 x 18</b>	22	63	1	<b>101127/16</b>	<b>29,311</b>
	<b>1/2 x 16</b>	24	75	1	<b>101121/2</b>	<b>34,838</b>
	<b>9/16 x 16</b>	28	80	1	<b>101129/16</b>	<b>47,631</b>
	<b>5/8 x 14</b>	28	80	1	<b>101125/8</b>	<b>47,631</b>
	<b>3/4 x 12</b>	32	95	1	<b>101123/4</b>	<b>64,108</b>
	<b>7/8 x 11</b>	36	100	1	<b>101127/8</b>	<b>82,841</b>
	<b>1" x 10</b>	40	110	1	<b>101121"</b>	<b>106,346</b>



Per filettature in fori ciechi e passanti in acciaio da costruzione, acciai da bonifica, materiali metallici in genere sino a  $R_s \leq 800 \text{ N/mm}^2$ . For making threads in blind and through holes in structural steel, malleable cast iron, heat-treatable steel  $R_s \leq 800 \text{ N/mm}^2$  / Taraudage pour trous borgnes et débouchant des acier de construction et aciers traités  $R_s \leq 800 \text{ N/mm}^2$  / Para orificios ciegos y pasantes en materiales de hasta  $800 \text{ N/mm}^2$  / Für allgemeinen Einsatz in Baustähle, Automatenstähle und Vergütungsstähle  $R_s \leq 800 \text{ N/mm}^2$ .

## 10120

### Maschi a mano serie di 3 pezzi, fil. americana UNC a passo grosso

Hand taps, 3 pcs set, Unified Coarse Thread (UNC) / Jeux de 3 tarauds à main, filetage américain à pas gros UNC

Juegos de machos a mano, rosca unificada vasta UNC / Handgewindebohrer, dreiteiliger Satz, amerikanisches gewinde UNC

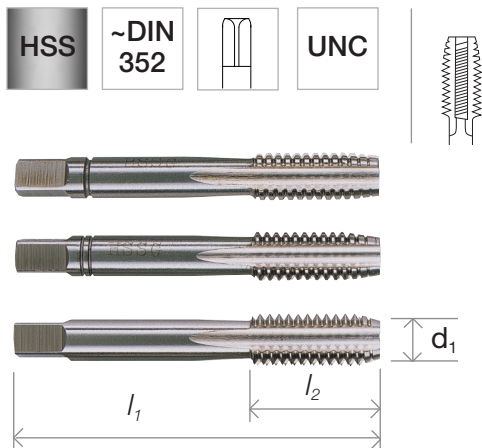

	$d_1$		$l_2$	$l_1$	pcs	cod.	€ cad/each
<b>N° 1</b>	x 64	10	32	1	10120N01	36,122	
<b>2</b>	x 56	11	36	1	10120N02	36,122	
<b>3</b>	x 48	11	36	1	10120N03	30,543	
<b>4</b>	x 40	12	40	1	10120N04	27,790	
<b>5</b>	x 40	12	40	1	10120N05	27,790	
<b>6</b>	x 32	14	45	1	10120N06	26,796	
<b>8</b>	x 32	14	45	1	10120N08	26,796	
<b>10</b>	x 24	16	50	1	10120N10	26,796	
<b>12</b>	x 24	18	50	1	10120N12	26,796	
<b>UNC 1/4</b>	x 20	19	50	1	101201/4	28,752	
<b>5/16</b>	x 18	22	63	1	101205/16	28,752	
<b>3/8</b>	x 16	24	70	1	101203/8	35,190	
<b>7/16</b>	x 14	24	70	1	101207/16	39,330	
<b>1/2</b>	x 13	29	75	1	101201/2	53,820	
<b>9/16</b>	x 12	30	80	1	101209/16	62,690	
<b>5/8</b>	x 11	32	80	1	101205/8	67,430	
<b>3/4</b>	x 10	40	95	1	101203/4	105,787	
<b>7/8</b>	x 12	40	100	1	101207/8	134,001	
<b>1"</b>	x 8	50	110	1	101201"	175,950	
<b>1.1/8</b>	x 7	56	132	1	101201.1/8	277,628	
<b>1.1/4</b>	x 7	56	132	1	101201.1/4	381,739	
<b>1.3/8</b>	x 6	63	150	1	101201.3/8	629,135	
<b>1.1/2</b>	x 6	63	150	1	101201.1/2	629,135	
<b>1.5/8</b>	x 5	70	160	1	101201.5/8	953,773	
<b>1.3/4</b>	x 5	70	160	1	101201.3/4	953,773	
<b>1.7/8</b>	x 4,5	80	190	1	101201.7/8	1332,149	
<b>2"</b>	x 4,5	80	190	1	101202"	1332,149	



**Acciaio**  
Steel

**Metals**

Per filettature in fori ciechi e passanti in acciaio da costruzione, acciai da bonifica, materiali metallici in genere sino a  $R_s \leq 800 \text{ N/mm}^2$ . For making threads in blind and through holes in structural steel, malleable cast iron, heat-treatable steel  $R_s \leq 800 \text{ N/mm}^2$  / Taraudage pour trous borgnes et débouchant des acier de construction et aciers traités  $R_s \leq 800 \text{ N/mm}^2$  / Para orificios ciegos y pasantes en materiales de hasta  $800 \text{ N/mm}^2$  / Für allgemeinen Einsatz in Baustähle, Automatenstähle und Vergütungsstähle  $R_s \leq 800 \text{ N/mm}^2$ .

# 10122

## Maschi a mano serie di 3 pezzi, filettatura americana sinistra UNC

Hand taps, 3 pcs set left hand / Jeux de 3 tarauds à main gauche

Juegos de machos a mano izquierda / Handgewindebohrer, linksgewinde dreiteiliger Satz

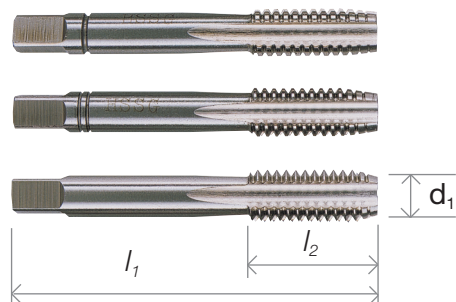
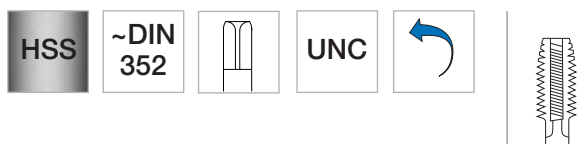

	$d_1$	$l_2$	$l_1$	pcs 	cod.	€ cad/each
<b>N° 6</b>	x 32	14	45	1	10122NR06	84,528
<b>8</b>	x 32	14	45	1	10122NR08	84,528
<b>10</b>	x 24	16	50	1	10122NR10	84,528
<b>12</b>	x 24	18	50	1	10122NR12	84,528
<b>UNC 1/4</b>	x 20	19	50	1	101221/4	53,541
<b>5/16</b>	x 18	22	63	1	101225/16	56,376
<b>3/8</b>	x 16	24	70	1	101223/8	65,712
<b>7/16</b>	x 14	24	70	1	101227/16	79,819
<b>1/2</b>	x 13	29	75	1	101221/2	95,789
<b>9/16</b>	x 12	30	80	1	101229/16	124,914
<b>5/8</b>	x 11	32	80	1	101225/8	140,822
<b>3/4</b>	x 10	40	95	1	101223/4	187,790
<b>7/8</b>	x 9	40	100	1	101227/8	234,748
<b>1"</b>	x 8	50	110	1	101221"	281,717



Per filettature in fori ciechi e passanti in acciaio da costruzione, acciai da bonifica, materiali metallici in genere sino a  $R_s \leq 800 \text{ N/mm}^2$ . For making threads in blind and through holes in structural steel, malleable cast iron, heat-treatable steel  $R_s \leq 800 \text{ N/mm}^2$  / Taraudage pour trous borgnes et débouchant des acier de construction et aciers traités  $R_s \leq 800 \text{ N/mm}^2$  / Para orificios ciegos y pasantes en materiales de hasta  $800 \text{ N/mm}^2$  / Für allgemeinen Einsatz in Baustähle, Automatenstähle und Vergütungsstähle  $R_s \leq 800 \text{ N/mm}^2$ .

## 10125

### Maschi a mano serie di 2 pezzi, filettatura americana UNF a passo fine

Hand taps, 2 pcs set, unified fine thread UNF / Jeux de 2 tarauds à main, filetage américain à pas fin UNF

Juego de 2 machos a mano, rosca unificada fina UNF / Handgewindebohrer, zweiteiliger Satz, amerikanisches Feingewinde

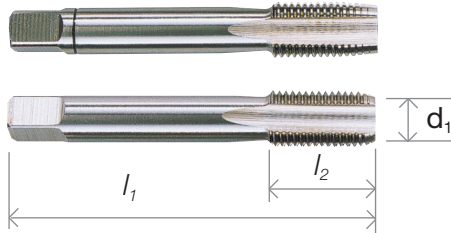
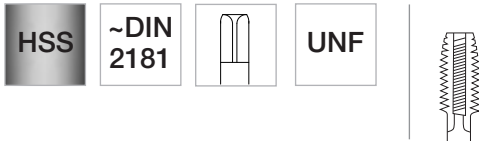

	$d_1$		$l_2$	$l_1$	pcs	cod.	€ cad/each
<b>N° 1</b>	x 72	9	32	1	10125N01	<a href="#">37,084</a>	
<b>2</b>	x 64	10	32	1	10125N02	<a href="#">37,084</a>	
<b>3</b>	x 56	10	32	1	10125N03	<a href="#">32,427</a>	
<b>4</b>	x 48	11	36	1	10125N04	<a href="#">31,278</a>	
<b>5</b>	x 44	11	36	1	10125N05	<a href="#">30,129</a>	
<b>6</b>	x 40	12	40	1	10125N06	<a href="#">24,116</a>	
<b>8</b>	x 36	12	40	1	10125N08	<a href="#">24,116</a>	
<b>10</b>	x 32	14	45	1	10125N10	<a href="#">24,116</a>	
<b>12</b>	x 28	14	50	1	10125N12	<a href="#">24,116</a>	
<b>UNF 1/4</b>	x 28	18	50	1	101251/4	<a href="#">25,947</a>	
<b>5/16</b>	x 24	22	56	1	101255/16	<a href="#">25,947</a>	
<b>3/8</b>	x 24	22	63	1	101253/8	<a href="#">28,121</a>	
<b>7/16</b>	x 20	22	63	1	101257/16	<a href="#">33,348</a>	
<b>1/2</b>	x 20	24	75	1	101251/2	<a href="#">39,444</a>	
<b>9/16</b>	x 18	28	80	1	101259/16	<a href="#">54,845</a>	
<b>5/8</b>	x 18	28	80	1	101255/8	<a href="#">60,610</a>	
<b>3/4</b>	x 16	32	95	1	101253/4	<a href="#">75,731</a>	
<b>7/8</b>	x 14	36	100	1	101257/8	<a href="#">96,276</a>	
<b>1"</b>	x 12	40	110	1	101251"12	<a href="#">122,016</a>	
<b>* 1"</b>	x 14	40	110	1	101251"14	<a href="#">202,622</a>	
<b>1.1/8</b>	x 12	50	110	1	101251.1/8	<a href="#">275,382</a>	
<b>1.1/4</b>	x 12	56	132	1	101251.1/4	<a href="#">343,672</a>	
<b>1.3/8</b>	x 12	56	132	1	101251.3/8	<a href="#">565,327</a>	
<b>1.1/2</b>	x 12	63	150	1	101251.1/2	<a href="#">565,327</a>	

\* Filettatura UNS  
UNS thread



Per filettature in fori ciechi e passanti in acciaio da costruzione, acciai da bonifica, materiali metallici in genere sino a  $R_s \leq 800$  N/mm<sup>2</sup>. For making threads in blind and through holes in structural steel, malleable cast iron, heat-treatable steel  $R_s \leq 800$  N/mm<sup>2</sup> / Taraudage pour trous borgnes et débouchant des acier de construction et aciers traités  $R_s \leq 800$  N/mm<sup>2</sup> / Para orificios ciegos y pasantes en materiales de hasta 800 N/mm<sup>2</sup> / Für allgemeinen Einsatz in Baustähle, Automatenstähle und Vergütungsstähle  $R_s \leq 800$  N/mm<sup>2</sup>.

# 10127

## Maschi a mano serie di 2 pezzi, filettatura americana sinistra UNF

Hand taps, 2 pcs set left hand / Jeux de 2 tarauds à main gauche

Juegos de machos a mano izquierda / Handgewindebohrer, linksgewinde zweitelliger Satz

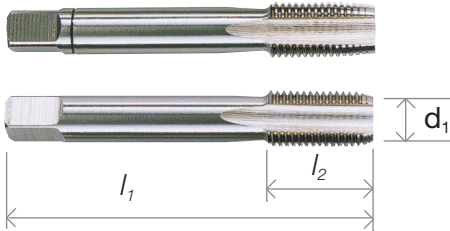

$d_1$	$l_2$	$l_1$	pcs 	cod.	€ cad/each
<b>N° 10</b> x 32	14	45	1	10127NR10	53,924
<b>UNF 1/4</b> x 28	18	50	1	101271/4	34,135
<b>5/16</b> x 24	22	56	1	101275/16	35,925
<b>3/8</b> x 24	22	63	1	101273/8	41,928
<b>7/16</b> x 20	22	63	1	101277/16	50,922
<b>1/2</b> x 20	24	75	1	101271/2	61,065
<b>9/16</b> x 18	28	80	1	101279/16	79,633
<b>5/8</b> x 18	28	80	1	101275/8	89,838
<b>3/4</b> x 16	32	95	1	101273/4	119,781
<b>7/8</b> x 14	36	100	1	101277/8	149,702
<b>1"</b> x 12	40	110	1	101271"	179,624



Per filettature in fori ciechi e passanti in acciaio da costruzione, acciai da bonifica, materiali metallici in genere sino a  $R_s \leq 800 \text{ N/mm}^2$ . For making threads in blind and through holes in structural steel, malleable cast iron, heat-treatable steel  $R_s \leq 800 \text{ N/mm}^2$  / Taraudage pour trous borgnes et débouchant des acier de construction et aciers traités  $R_s \leq 800 \text{ N/mm}^2$  / Para orificios ciegos y pasantes en materiales de hasta  $800 \text{ N/mm}^2$  / Für allgemeinen Einsatz in Baustähle, Automatenstähle und Vergütungsstähle  $R_s \leq 800 \text{ N/mm}^2$ .

## 10134

### Maschi a mano / macchina conici per tubi, filettatura americana

Taper thread taps / Tarauds conique

Machos rosca conica americana / Gewindebohrer, amerikanisches kegeliges Rohrgewinde

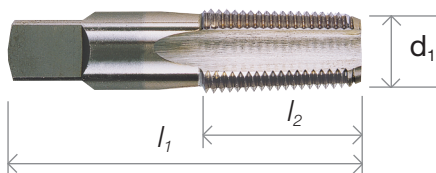

$d_1$	$l_2$	$l_1$	pcs	cod.	€ cad/each
<b>NPT 1/8</b> x 27	19	54	1	101341/8	36,939
<b>1/4</b> x 18	27	62	1	101341/4	42,797
<b>3/8</b> x 18	27	65	1	101343/8	52,920
<b>1/2</b> x 14	35	79	1	101341/2	80,130
<b>3/4</b> x 14	35	83	1	101343/4	132,097
<b>1"</b> x 11,5	44	95	1	101341"	207,104
<b>1.1/4</b> x 11,5	44	102	1	101341.1/4	330,237
<b>1.1/2</b> x 11,5	44	108	1	101341.1/2	429,867
<b>2"</b> x 11,5	44	114	1	101342"	771,303

## 10139

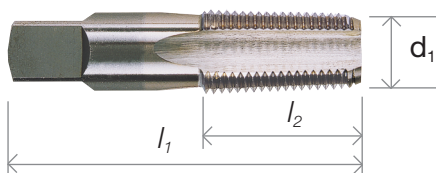

$d_1$	$l_2$	$l_1$	pcs	cod.	€ cad/each
<b>Rc 1/8</b> x 28	15	59	1	101391/8	36,939
<b>1/4</b> x 19	19	67	1	101391/4	42,797
<b>3/8</b> x 19	21	75	1	101393/8	52,920
<b>1/2</b> x 14	26	87	1	101391/2	70,515
<b>3/4</b> x 14	28	96	1	101393/4	110,269
<b>1"</b> x 11	33	109	1	101391"	157,848
<b>1.1/4</b> x 11	36	119	1	101391.1/4	272,029
<b>1.1/2</b> x 11	37	125	1	101391.1/2	353,753
<b>2"</b> x 11	41	140	1	101392"	629,135

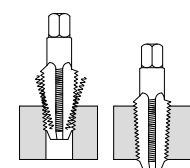

CONICITA' 1:16  
TAPER 1:16

# 10293

## Maschi a macchina conici per tubi, filettatura americana

Machine taps / Tarauds machine

Machos de maquina / Machinengewindebohrer

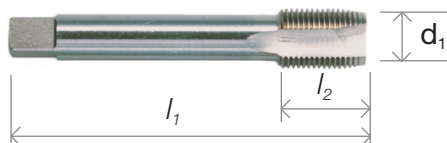

$d_1$	$l_2$	$l_1$	$d_2$	pcs	cod.	€ cad/each
<b>NPT 1/8 x 27</b>	20	90	7	1	102931/8	51,543
<b>1/4 x 18</b>	22	100	11	1	102931/4	64,584
<b>3/8 x 18</b>	22	100	12	1	102933/8	80,502
<b>1/2 x 14</b>	28	125	16	1	102931/2	113,105
<b>3/4 x 14</b>	28	140	20	1	102933/4	167,908
<b>1" x 11,5</b>	38	160	25	1	102931"	241,259

# 10294

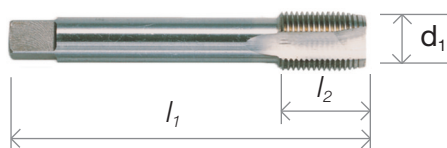

$d_1$	$l_2$	$l_1$	$d_2$	pcs	cod.	€ cad/each
<b>Rc 1/8 x 28</b>	20	90	7	1	102941/8	51,543
<b>1/4 x 19</b>	22	100	11	1	102941/4	64,584
<b>3/8 x 19</b>	22	100	12	1	102943/8	80,502
<b>1/2 x 14</b>	28	125	16	1	102941/2	113,105
<b>3/4 x 14</b>	28	140	20	1	102943/4	167,908
<b>1" x 11</b>	38	160	25	1	102941"	241,259



## 10306

### Maschi a macchina corti per tubi, filettatura conica americana

Short machine taps for pipes / Tarauds machine courte

Machos de maquina cortos para tubos / Kurzmaschinen-Gewindebohrer

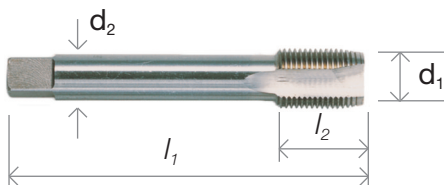

$d_1$	$l_2$	$l_1$	$d_2$	pcs	cod.	€ cad/each
<b>NPTF 1/16</b> x 27	19	55	6,5	1	103061/16	23,100
<b>1/8</b> x 27	19	55	8	1	103061/8	25,200
<b>1/4</b> x 18	28	62	11	1	103061/4	30,108
<b>3/8</b> x 18	28	65	14	1	103063/8	36,402
<b>1/2</b> x 14	35	80	18	1	103061/2	65,340
<b>3/4</b> x 14	35	85	23	1	103063/4	86,820
<b>1"</b> x 11,5	45	95	26	1	103061"	124,146
<b>1.1/4</b> x 11,5	45	105	32	1	103061.1/4	255,552
<b>1.1/2</b> x 11,5	45	110	38	1	103061.1/2	320,904
<b>2"</b> x 11,5	50	120	46	1	103062"	476,088

## 10307

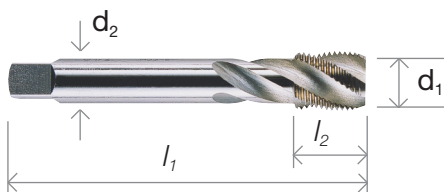

$d_1$	$l_2$	$l_1$	$d_2$	pcs	cod.	€ cad/each
<b>NPTF 1/8</b> x 27	19	55	8	1	103071/8	27,720
<b>1/4</b> x 18	28	62	11	1	103071/4	33,119
<b>3/8</b> x 18	28	65	14	1	103073/8	40,042
<b>1/2</b> x 14	35	80	18	1	103071/2	71,874
<b>3/4</b> x 14	35	85	23	1	103073/4	95,502
<b>1"</b> x 11,5	45	95	26	1	103071"	136,561

# 10308

## Maschi a macchina corti per tubi, filettatura cilindrica americana

Short machine taps for pipes / Tarauds machine courte

Machos de maquina cortos para tubos / Kurzmaschinen-Gewindebohrer

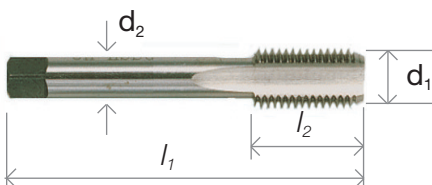

	$d_1$	$l_2$	$l_1$	$d_2$	pcs	cod.	€ cad/each
<b>NPS</b>	<b>1/16</b> x 27	17,5	54	8	1	103081/16	25,098
	<b>1/8</b> x 27	19	55	8	1	103081/8	31,500
	<b>1/4</b> x 18	28	62	11	1	103081/4	37,638
	<b>3/8</b> x 18	28	65	14	1	103083/8	45,504
	<b>1/2</b> x 14	35	80	18	1	103081/2	65,340
	<b>3/4</b> x 14	35	85	23	1	103083/4	86,820
	<b>1"</b> x 11,5	45	95	26	1	103081"	124,140
	<b>1.1/4</b> x 11,5	45	105	32	1	103081.1/4	255,540
	<b>1.1/2</b> x 11,5	45	110	38	1	103081.1/2	320,880
	<b>2"</b> x 11,5	50	120	46	1	103082"	476,040

# 10309

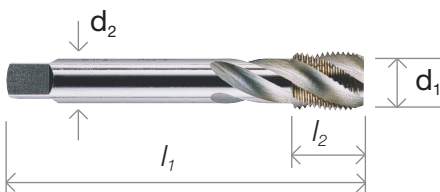
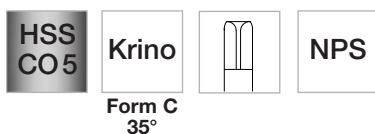

	$d_1$	$l_2$	$l_1$	$d_2$	pcs	cod.	€ cad/each
<b>NPS</b>	<b>1/16</b> x 27	17,5	54	8	1	103091/16	27,608
	<b>1/8</b> x 27	19	55	8	1	103091/8	34,650
	<b>1/4</b> x 18	28	62	11	1	103091/4	41,402
	<b>3/8</b> x 18	28	65	14	1	103093/8	50,054
	<b>1/2</b> x 14	35	80	18	1	103091/2	71,874
	<b>3/4</b> x 14	35	85	23	1	103093/4	95,502
	<b>1"</b> x 11,5	45	95	26	1	103091"	136,554
	<b>1.1/4</b> x 11,5	45	105	32	1	103091.1/4	281,094
	<b>1.1/2</b> x 11,5	45	110	38	1	103091.1/2	352,968
	<b>2"</b> x 11,5	50	120	46	1	103092"	523,644

## 12060

### Filiera tonde ad imbocco corretto, filettatura metrica ISO a passo grosso

Spiral point round dies, metric coarse thread / Filières rondes entrée gun, filetage métrique à pas gros

Cojinetes redondos entrada corregida, rosca metrica vasta / Runde Schneideisen mit schälanschnitt metrisches ISO-Gewinde

**HSS** **DIN 223** **EN 22568** **6g** **M**

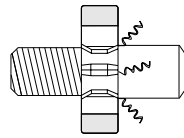
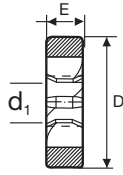

**Imbocco corretto**  
Spiral Point



$d_1$	DxE	pcs	cod.	€	$d_1$	DxE	pcs	cod.	€
				cad/each					cad/each
<b>M 1</b> x 0,25	16 x 5	1	1206001X025	36,525	<b>M 11</b> x 1,5	30 x 11	1	1206011X15	30,284
<b>1,1</b> x 0,25	16 x 5	1	12060011X025	36,525	<b>12</b> x 1,75	38 x 14	1	1206012X175	28,214
<b>1,2</b> x 0,25	16 x 5	1	12060012X025	36,525	<b>14</b> x 2	38 x 14	1	1206014X2	29,663
<b>1,4</b> x 0,3	16 x 5	1	12060014X03	36,525	<b>15</b> x 2	38 x 14	1	1206015X2	46,575
<b>1,6</b> x 0,35	16 x 5	1	12060016X035	36,525	<b>16</b> x 2	45 x 18	1	1206016X2	36,266
<b>1,7</b> x 0,35	16 x 5	1	12060017X035	36,525	<b>18</b> x 2,5	45 x 18	1	1206018X25	39,816
<b>1,8</b> x 0,35	16 x 5	1	12060018X035	36,525	<b>19</b> x 2,5	45 x 18	1	1206019X25	46,575
<b>2</b> x 0,4	16 x 5	1	1206002X04	17,574	<b>20</b> x 2,5	45 x 18	1	1206020X25	41,193
<b>2,2</b> x 0,45	16 x 5	1	12060022X045	22,439	<b>22</b> x 2,5	55 x 22	1	1206022X25	68,289
<b>2,3</b> x 0,4	16 x 5	1	12060023X04	22,439	<b>24</b> x 3	55 x 22	1	1206024X3	80,461
<b>2,5</b> x 0,45	16 x 5	1	12060025X045	17,709	<b>27</b> x 3	65 x 25	1	1206027X3	107,112
<b>2,6</b> x 0,45	16 x 5	1	12060026X045	22,439	<b>30</b> x 3,5	65 x 25	1	1206030X35	115,868
<b>3</b> x 0,5	20 x 5	1	1206003X05	14,421	<b>33</b> x 3,5	65 x 25	1	1206033X35	126,839
<b>3,5</b> x 0,6	20 x 5	1	12060035X06	22,439	<b>36</b> x 4	65 x 25	1	1206036X4	130,534
<b>4</b> x 0,7	20 x 5	1	1206004X07	14,821	<b>39</b> x 4	75 x 30	1	1206039X4	190,864
<b>4,5</b> x 0,75	20 x 7	1	12060045X075	17,709	<b>42</b> x 4,5	75 x 30	1	1206042X45	203,181
<b>5</b> x 0,8	20 x 7	1	1206005X08	15,328	<b>45</b> x 4,5	90 x 36	1	1206045X45	301,692
<b>5</b> x 1	20 x 7	1	1206005X1	67,275	<b>48</b> x 5	90 x 36	1	1206048X5	274,265
<b>5,5</b> x 0,9	20 x 7	1	12060055x09	22,553	<b>52</b> x 5	90 x 36	1	1206052X5	315,013
<b>6</b> x 1	20 x 7	1	1206006X1	16,084	<b>56</b> x 5,5	105 x 36	1	1206056X55	371,441
<b>7</b> x 1	25 x 9	1	1206007X1	18,113	<b>60</b> x 5,5	105 x 36	1	1206060X55	371,441
<b>8</b> x 1,25	25 x 9	1	1206008X125	17,046	<b>64</b> x 6	120 x 36	1	1206064X6	425,509
<b>9</b> x 1,25	25 x 9	1	1206009X125	21,714	<b>68</b> x 6	120 x 36	1	1206068X6	425,509
<b>10</b> x 1,5	30 x 11	1	1206010X15	19,261	<b>72</b> x 6	130 x 36	1	1206072X6	1441,755

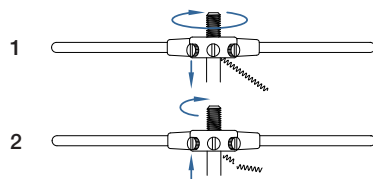

É buona norma, ad ogni rotazione della filiera<sup>(2)</sup>,  
effettuare mezzo giro indietro  
per rompere il truciolo<sup>(2)</sup>  
Please rotate clockwise the round die<sup>(2)</sup> then  
anticlockwise to break the chip<sup>(2)</sup>

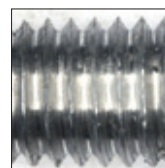

**Risultato: Ottima finitura del filetto**  
Result: good thread finishing



# 12066

## Filire tonde **non** a norma DIN, filettatura metrica ISO

Round dies with special outside diameter / Filières rondes avec diamètre extérieur spécial

Cojinetes redondos con diametro exterior special / Runde Schneideisen mit sonderen ausserendurchmesser

HSS

Krino

M

6g

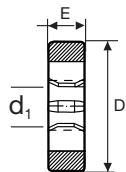

	d <sub>1</sub>	DxE	pcs	cod.	€ cad/each
<b>M</b>	2 x 0,4	25 x 9	1	12066202X04	24,633
	3 x 0,5	25 x 9	1	12066203X05	10,857
	4 x 0,7	25 x 9	1	12066204X07	10,857
	5 x 0,8	25 x 9	1	12066205X08	10,857
	6 x 1	25 x 9	1	12066206X1	10,857
	7 x 1	25 x 9	1	12066207X1	10,857
	8 x 1,25	25 x 9	1	12066208X125	10,857
	10 x 1,5	25 x 9	1	12066210X15	10,857

	d <sub>1</sub>	DxE	pcs	cod.	€ cad/each
<b>M</b>	12 x 1,75	25 x 9	1	12066212X175	12,875
	10 x 1,5	38 x 14	1	12066310X15	18,413
	12 x 1,75	38 x 14	1	12066312X175	22,190
	14 x 2	38 x 14	1	12066314X2	22,190
	16 x 2	38 x 14	1	12066316X2	22,190
	18 x 2,5	38 x 14	1	12066318X25	25,523
	20 x 2,5	38 x 14	1	12066320X25	25,523

HSS

Krino

MF

6g

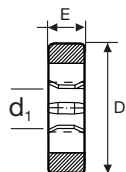

	d <sub>1</sub>	DxE	pcs	cod.	€ cad/each
<b>M</b>	8 x 1	25 x 9	1	12066208X1	10,588
	10 x 1	38 x 14	1	12066310X1	18,433
	10 x 1,25	38 x 14	1	12066310X125	18,433
	12 x 1,25	38 x 14	1	12066312X125	22,190
	12 x 1,5	38 x 14	1	12066312X15	22,190

	d <sub>1</sub>	DxE	pcs	cod.	€ cad/each
<b>M</b>	14 x 1,25	38 x 14	1	12066314X125	22,190
	14 x 1,5	38 x 14	1	12066314X15	22,190
	16 x 1,5	38 x 14	1	12066316X15	22,190
	18 x 1,5	38 x 14	1	12066318X15	25,523



Acciaio  
Steel



Metals



## 12144

### Filire tonde ad imbocco corretto, filettatura metrica ISO a passo grosso

Round dies, spiral point, metric coarse thread / Filières rondes, entrée gun, filetage métrique à pas gros

Cojinetes redondos, entrada corregida, rosca metrica vasta / Runde Schneideisen mit schälanschnitt

HSS CO5	DIN 223	EN 22568	M	6g
------------	------------	-------------	---	----

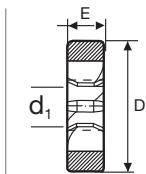

	d <sub>1</sub>	DxE	pcs 	cod.	€ cad/each
<b>M</b>	3 x 0,5	20 x 5	1	1214403X05	17,730
	4 x 0,7	20 x 5	1	1214404X07	17,730
	5 x 0,8	20 x 7	1	1214405X08	18,195
	6 x 1	20 x 7	1	1214406X1	18,195
	8 x 1,25	25 x 9	1	1214408X125	18,920
	10 x 1,5	30 x 11	1	1214410X15	22,501
	12 x 1,75	38 x 14	1	1214412X175	35,066
	14 x 2	38 x 14	1	1214414X2	40,293
	16 x 2	45 x 18	1	1214416X2	54,182
	18 x 2,5	45 x 18	1	1214418X25	64,056
	20 x 2,5	45 x 18	1	1214420X25	64,056
	22 x 2,5	55 x 22	1	1214422X25	107,464
	24 x 3	55 x 22	1	1214424X3	107,464
	27 x 3	65 x 25	1	1214427X3	150,075
	30 x 3,5	65 x 25	1	1214430X35	150,075

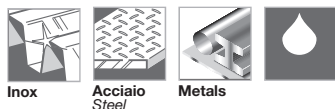

# 12062

## Filiera tonde **sinistre**, filettatura metrica ISO a passo grosso

Round dies, metric coarse thread, left hand / Filières rondes, filetage métrique à pas gros, gauche

Cojinetes redondos, rosca metrica vasta izquierda / Runde Schneideisen, metrisches ISO-Gewinde, linksgewinde

HSS

DIN  
223

EN  
22568

M

6g

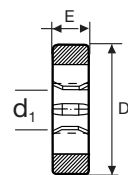

	d <sub>1</sub>	DxE	pcs 	cod.	€ cad/each
<b>M</b>	2 x 0,4	16 x 5	1	1206202X04	25,233
	3 x 0,5	20 x 5	1	1206203X05	19,189
	4 x 0,7	20 x 5	1	1206204X07	19,189
	5 x 0,8	20 x 7	1	1206205X08	19,851
	6 x 1	20 x 7	1	1206206X1	19,851
	7 x 1	25 x 9	1	1206207X1	24,136
	8 x 1,25	25 x 9	1	1206208X125	21,031
	10 x 1,5	30 x 11	1	1206210X15	25,275
	12 x 1,75	38 x 14	1	1206212X175	38,740
	14 x 2	38 x 14	1	1206214X2	38,740
	16 x 2	45 x 18	1	1206216X2	52,071
	18 x 2,5	45 x 18	1	1206218X25	62,990
	20 x 2,5	45 x 18	1	1206220X25	62,990
	22 x 2,5	55 x 22	1	1206222X25	120,308
	24 x 3	55 x 22	1	1206224X3	120,308
	27 x 3	65 x 25	1	1206227X3	168,477
	30 x 3,5	65 x 25	1	1206230X35	168,477
	33 x 3,5	65 x 25	1	1206233X35	188,525
	36 x 4	65 x 25	1	1206236X4	207,104
	39 x 4	75 x 30	1	1206239X4	245,907
	42 x 4,5	75 x 30	1	1206242X45	245,907
	45 x 4,5	90 x 36	1	1206245X45	544,058
	48 x 5	90 x 36	1	1206248X5	544,058
	52 x 5	90 x 36	1	1206252X5	544,058



Acciaio  
Steel

Metals

## 12165

### Filire tonde ad imbocco corretto riv. al TiN, fil. metrica ISO

TiN round dies, metric thread / Filières rondes revetue au titan, filetage métrique

Cojinetes redondos con recubrimiento de titanio / Runde Schneideisen TiN beschichtet

HSS	DIN 223	EN 22568	M	MF	6g
-----	------------	-------------	---	----	----

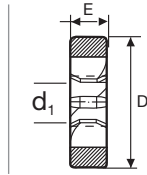

**TiN**  
HV 0,05  
2300



	d <sub>1</sub>	DxE	pcs 	cod.	€ cad/each
<b>M</b>	3 x 0,5	20 x 5	1	1216503X05	18,423
	4 x 0,7	20 x 5	1	1216504X07	18,423
	5 x 0,8	20 x 7	1	1216505X08	18,816
	6 x 1	20 x 7	1	1216506X1	18,816
	8 x 1,25	25 x 9	1	1216508X125	21,280
	10 x 1,5	30 x 11	1	1216510X15	25,647
	12 x 1,75	38 x 14	1	1216512X175	37,136
	14 x 2	38 x 14	1	1216514X2	37,136
	16 x 2	45 x 18	1	1216516X2	48,469
	18 x 2,5	45 x 18	1	1216518X25	56,304
	20 x 2,5	45 x 18	1	1216520X25	56,304

	d <sub>1</sub>	DxE	pcs 	cod.	€ cad/each
<b>MF</b>	14 x 1,5	38 x 10	1	1216514X15	37,136
	16 x 1,5	45 x 14	1	1216516X15	48,479
	18 x 1,5	45 x 14	1	1216518X15	56,304
	22 x 1,5	45 x 14	1	1216522X15	106,502

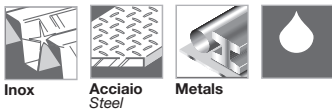

# 12069

## Filiera tonde per tubi di conduzione elettrica

Round dies for cables connections / Filières rondes pour tubes avec armature en acier

Cojinetes redondos para tubos de conducción eléctrica/ Runde Schneideisen, Kabelverschraubungen

<b>HSS</b>	<b>DIN 223</b>	<b>EN 22568</b>	<b>MF</b>	<b>6g</b>
------------	----------------	-----------------	-----------	-----------

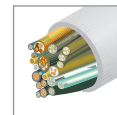
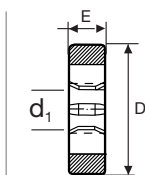

$d_1$	DxE	pcs	cod.	€ cad/each	$d_1$	DxE	pcs	cod.	€ cad/each
<b>M 12</b> x 1,5	38 x 10	1	1206912X15	<b>28,142</b>	<b>M 32</b> x 1,5	65 x 18	1	1206932X15	<b>159,908</b>
<b>16</b> x 1,5	45 x 14	1	1206916X15	<b>39,992</b>	<b>40</b> x 1,5	75 x 20	1	1206940X15	<b>284,118</b>
<b>20</b> x 1,5	45 x 14	1	1206920X15	<b>51,553</b>	<b>50</b> x 1,5	90 x 22	1	1206950X15	<b>455,918</b>
<b>25</b> x 1,5	55 x 16	1	1206925X15	<b>114,181</b>	<b>63</b> x 1,5	105 x 22	1	1206963X15	<b>882,131</b>

# 12093

<b>HSS</b>	<b>DIN 40434</b>	<b>Pg</b>
------------	------------------	-----------

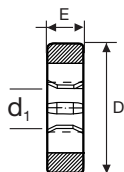

$d_1$	DxE	pcs	cod.	€ cad/each	$d_1$	DxE	pcs	cod.	€ cad/each
<b>Pg 7</b> x 20	38 x 10	1	1209307	<b>83,887</b>	<b>Pg 21</b> x 16	65 x 18	1	1209321	<b>184,706</b>
<b>9</b> x 18	45 x 14	1	1209309	<b>100,695</b>	<b>29</b> x 16	65 x 18	1	1209329	<b>184,706</b>
<b>11</b> x 18	45 x 14	1	1209311	<b>100,695</b>	<b>36</b> x 16	90 x 22	1	1209336	<b>403,898</b>
<b>13,5</b> x 18	45 x 14	1	12093135	<b>100,695</b>	<b>42</b> x 16	105 x 22	1	1209342	<b>511,031</b>
<b>16</b> x 18	55 x 16	1	1209316	<b>117,431</b>	<b>48</b> x 16	105 x 22	1	1209348	<b>511,031</b>





## 12065

### Filiera tonde ad imbocco corretto, filettatura metrica a passo fine

Round dies, spiral point, metric fine thread / Filières rondes, entrée gun, filetage métrique à pas fin

Cojinetes redondos, entrada corregida, rosca métrica fina / Runde Schneideisen mit schälanschnitt, metrisches ISO-Feingewinde

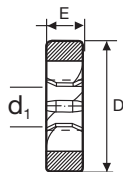

d <sub>1</sub>	DxE		cod.	€ cad/each	d <sub>1</sub>	DxE		cod.	€ cad/each
M 2,5 x 0,35	16 x 5	1	12065025X035	35,180	15 x 1	38 x 10	1	1206515X1	73,216
2,6 x 0,35	16 x 5	1	12065026X035	35,180	15 x 1,5	38 x 10	1	1206515X15	53,013
3 x 0,35	20 x 5	1	1206503X035	18,475	16 x 0,5	45 x 14	1	1206516X05	90,687
3,5 x 0,35	20 x 5	1	12065035X035	22,170	16 x 0,75	45 x 14	1	1206516X075	90,687
4 x 0,35	20 x 5	1	1206504X035	29,052	16 x 1	45 x 14	1	1206516X1	39,992
4 x 0,5	20 x 5	1	1206504X05	18,475	16 x 1,25	45 x 14	1	1206516X125	60,030
4,5 x 0,5	20 x 5	1	12065045X05	32,913	16 x 1,5	45 x 14	1	1206516X15	39,992
5 x 0,5	20 x 5	1	1206505X05	18,475	17 x 1	45 x 14	1	1206517X1	73,216
5 x 0,75	20 x 7	1	1206505X075	25,244	17 x 1,5	45 x 14	1	1206517X15	90,563
5,5 x 0,5	20 x 5	1	12065055X05	32,913	18 x 0,5	45 x 14	1	1206518X05	90,563
6 x 0,5	20 x 5	1	1206506X05	25,244	18 x 0,75	45 x 14	1	1206518X075	90,563
6 x 0,75	20 x 7	1	1206506X075	25,244	18 x 1	45 x 14	1	1206518X1	48,604
7 x 0,5	25 x 9	1	1206507X05	32,913	18 x 1,25	45 x 14	1	1206518X125	73,216
7 x 0,75	25 x 9	1	1206507X075	25,244	18 x 1,5	45 x 14	1	1206518X15	48,604
8 x 0,5	25 x 9	1	1206508X05	25,244	18 x 2	45 x 14	1	1206518X2	48,604
8 x 0,75	25 x 9	1	1206508X075	20,120	19 x 1	45 x 14	1	1206519X1	99,360
8 x 1	25 x 9	1	1206508X1	20,120	19 x 1,5	45 x 14	1	1206519X15	73,216
9 x 0,5	25 x 9	1	1206509X05	44,329	20 x 0,5	45 x 14	1	1206520X05	99,360
9 x 0,75	25 x 9	1	1206509X075	44,329	20 x 0,75	45 x 14	1	1206520X075	99,360
9 x 1	25 x 9	1	1206509X1	27,376	20 x 1	45 x 14	1	1206520X1	51,553
10 x 0,5	30 x 11	1	1206510X05	44,329	20 x 1,25	45 x 14	1	1206520X125	51,553
10 x 0,75	30 x 11	1	1206510X075	24,084	20 x 1,5	45 x 14	1	1206520X15	51,553
10 x 1	30 x 11	1	1206510X1	22,615	20 x 2	45 x 14	1	1206520X2	51,553
10 x 1,25	30 x 11	1	1206510X125	22,615	21 x 1	45 x 14	1	1206521X1	98,325
11 x 1	30 x 11	1	1206511X1	33,141	21 x 1,5	45 x 14	1	1206521X15	87,323
11 x 1,25	30 x 11	1	1206511X125	33,141	22 x 0,5	55 x 16	1	1206522X05	139,032
12 x 0,5	38 x 10	1	1206512X05	43,542	22 x 0,75	55 x 16	1	1206522X075	139,032
12 x 0,75	38 x 10	1	1206512X075	43,542	22 x 1	55 x 16	1	1206522X1	80,834
12 x 1	38 x 10	1	1206512X1	29,218	22 x 1,25	55 x 16	1	1206522X125	80,834
12 x 1,25	38 x 10	1	1206512X125	29,218	22 x 1,5	55 x 16	1	1206522X15	75,555
12 x 1,5	38 x 10	1	1206512X15	28,142	22 x 2	55 x 16	1	1206522X2	75,555
13 x 0,5	38 x 10	1	1206513X05	56,201	23 x 1	55 x 16	1	1206523X1	157,175
13 x 0,75	38 x 10	1	1206513X075	56,201	23 x 1,5	55 x 16	1	1206523X15	157,175
13 x 1	38 x 10	1	1206513X1	45,851	24 x 0,5	55 x 16	1	1206524X05	157,175
13 x 1,5	38 x 10	1	1206513X15	45,851	24 x 0,75	55 x 16	1	1206524X075	157,175
14 x 0,5	38 x 10	1	1206514X05	56,283	24 x 1	55 x 16	1	1206524X1	82,283
14 x 0,75	38 x 10	1	1206514X075	56,283	24 x 1,25	55 x 16	1	1206524X125	82,283
14 x 1	38 x 10	1	1206514X1	31,143	24 x 1,5	55 x 16	1	1206524X15	82,283
14 x 1,25	38 x 10	1	1206514X125	31,143	24 x 2	55 x 16	1	1206524X2	82,283
14 x 1,5	38 x 10	1	1206514X15	31,143	25 x 1	55 x 16	1	1206525X1	114,181
15 x 0,75	38 x 10	1	1206515X075	84,197	25 x 1,5	55 x 16	1	1206525X15	114,181



# 12065

d <sub>1</sub>	DxE		cod.	€ cad/each
25 x 2	55 x 16	1	1206525X2	105,591
26 x 1	55 x 16	1	1206526X1	142,664
26 x 1,5	55 x 16	1	1206526X15	142,664
26 x 2	55 x 16	1	1206526X2	142,664
27 x 1	65 x 18	1	1206527X1	161,460
27 x 1,5	65 x 18	1	1206527X15	161,460
27 x 2	65 x 18	1	1206527X2	161,460
28 x 1	65 x 18	1	1206528X1	161,460
28 x 1,5	65 x 18	1	1206528X15	161,460
28 x 2	65 x 18	1	1206528X2	161,460
29 x 1,5	65 x 18	1	1206529X15	161,460
30 x 1	65 x 18	1	1206530X1	161,460
30 x 1,5	65 x 18	1	1206530X15	161,460
30 x 2	65 x 18	1	1206530X2	161,460
30 x 2,5	65 x 18	1	1206530X25	161,460
30 x 3	65 x 25	1	1206530X3	161,460
32 x 1	65 x 18	1	1206532X1	214,938
32 x 1,5	65 x 18	1	1206532X15	159,908
32 x 2	65 x 18	1	1206532X2	159,908
32 x 3	65 x 25	1	1206532X3	159,908
33 x 1,5	65 x 18	1	1206533X15	182,471
33 x 2	65 x 18	1	1206533X2	182,471
33 x 3	65 x 25	1	1206533X3	182,471
34 x 1	65 x 18	1	1206534X1	214,938
34 x 1,5	65 x 18	1	1206534X15	182,471
34 x 2	65 x 18	1	1206534X2	182,471
35 x 1	65 x 18	1	1206535X1	214,938
35 x 1,5	65 x 18	1	1206535X15	191,423
35 x 2	65 x 18	1	1206535X2	214,938
36 x 1	65 x 18	1	1206536X1	214,938
36 x 1,5	65 x 18	1	1206536X15	191,423
36 x 2	65 x 18	1	1206536X2	191,423
36 x 3	65 x 25	1	1206536X3	191,423
37 x 1,5	65 x 18	1	1206537X15	401,580
38 x 1	75 x 20	1	1206538X1	401,580
38 x 1,5	75 x 20	1	1206538X15	285,236
38 x 2	75 x 20	1	1206538X2	285,236
38 x 3	75 x 30	1	1206538X3	283,229
39 x 1,5	75 x 20	1	1206539X15	284,218
39 x 2	75 x 20	1	1206539X2	284,218
39 x 3	75 x 30	1	1206539X3	284,218
40 x 1	75 x 20	1	1206540X1	383,229
40 x 1,5	75 x 20	1	1206540X15	284,118
40 x 2	75 x 20	1	1206540X2	284,118
40 x 3	75 x 30	1	1206540X3	284,118
42 x 1	75 x 20	1	1206542X1	383,229
42 x 1,5	75 x 20	1	1206542X15	284,118
42 x 2	75 x 20	1	1206542X2	284,118
42 x 3	75 x 30	1	1206542X3	284,118
44 x 1,5	90 x 22	1	1206544X15	621,104
44 x 2	90 x 22	1	1206544X2	621,104
45 x 1	90 x 22	1	1206545X1	621,104
45 x 1,5	90 x 22	1	1206545X15	455,918
45 x 2	90 x 22	1	1206545X2	455,918
45 x 3	90 x 36	1	1206545X3	455,918
46 x 1,5	90 x 22	1	1206546X15	621,104
48 x 1	90 x 22	1	1206548X1	621,104
48 x 1,5	90 x 22	1	1206548X15	455,918
48 x 2	90 x 22	1	1206548X2	455,918
48 x 3	90 x 36	1	1206548X3	455,918
50 x 1,5	90 x 22	1	1206550X15	455,918
50 x 2	90 x 22	1	1206550X2	455,918
50 x 3	90 x 36	1	1206550X3	455,918
52 x 1,5	90 x 22	1	1206552X15	455,918
52 x 2	90 x 22	1	1206552X2	455,918
52 x 3	90 x 36	1	1206552X3	455,918
54 x 1	105 x 22	1	1206554X1	839,147
54 x 1,5	105 x 22	1	1206554X15	882,131
54 x 2	105 x 22	1	1206554X2	882,131

d <sub>1</sub>	DxE		cod.	€ cad/each
54 x 3	105 x 36	1	1206554X3	882,131
54 x 4	105 x 36	1	1206554X4	882,131
55 x 1,5	105 x 22	1	1206555X15	882,131
55 x 2	105 x 22	1	1206555X2	882,131
55 x 3	105 x 36	1	1206555X3	882,131
55 x 4	105 x 36	1	1206555X4	882,131
56 x 1	105 x 22	1	1206556X1	882,131
56 x 1,5	105 x 22	1	1206556X15	882,131
56 x 2	105 x 22	1	1206556X2	882,131
56 x 3	105 x 36	1	1206556X3	882,131
56 x 4	105 x 36	1	1206556X4	882,131
58 x 1	105 x 22	1	1206558X1	882,131
58 x 1,5	105 x 22	1	1206558X15	882,131
58 x 2	105 x 22	1	1206558X2	882,131
58 x 3	105 x 36	1	1206558X3	882,131
58 x 4	105 x 36	1	1206558X4	882,131
60 x 1,5	105 x 22	1	1206560X15	882,131
60 x 2	105 x 22	1	1206560X2	882,131
60 x 3	105 x 36	1	1206560X3	882,131
60 x 4	105 x 36	1	1206560X4	882,131
62 x 1,5	105 x 22	1	1206562X15	882,131
62 x 2	105 x 22	1	1206562X2	882,131
62 x 3	105 x 36	1	1206562X3	882,131
62 x 4	105 x 36	1	1206562X4	882,131
63 x 1,5	105 x 22	1	1206563X15	882,131
64 x 1,5	120 x 22	1	1206564X15	1010,874
64 x 2	120 x 22	1	1206564X2	1010,874
64 x 3	120 x 36	1	1206564X3	1010,874
64 x 4	120 x 36	1	1206564X4	1010,874
65 x 1,5	120 x 22	1	1206565X15	1010,874
65 x 2	120 x 22	1	1206565X2	1010,874
65 x 3	120 x 36	1	1206565X3	1010,874
65 x 4	120 x 36	1	1206565X4	1010,874
68 x 1,5	120 x 22	1	1206568X15	1010,874
68 x 2	120 x 22	1	1206568X2	1010,874
68 x 3	120 x 36	1	1206568X3	1010,874
68 x 4	120 x 36	1	1206568X4	1010,874
70 x 1,5	120 x 22	1	1206570X15	1010,874
70 x 2	120 x 22	1	1206570X2	1010,874
70 x 3	120 x 36	1	1206570X3	1010,874
70 x 4	120 x 36	1	1206570X4	1010,874
72 x 1,5	120 x 22	1	1206572X15	1010,874
72 x 2	120 x 22	1	1206572X2	1010,874
72 x 3	120 x 36	1	1206572X3	1010,874
72 x 4	120 x 36	1	1206572X4	1010,874
74 x 1,5	120 x 22	1	1206574X15	1010,874
74 x 2	120 x 22	1	1206574X2	1010,874
74 x 3	120 x 36	1	1206574X3	1010,874
74 x 4	120 x 36	1	1206574X4	1010,874
75 x 1,5	120 x 22	1	1206575X15	1010,874
75 x 2	120 x 22	1	1206575X2	1010,874
75 x 3	120 x 36	1	1206575X3	1010,874
75 x 4	120 x 36	1	1206575X4	1010,874
76 x 1,5	120 x 22	1	1206576X15	1010,874
76 x 2	120 x 22	1	1206576X2	1010,874
76 x 3	120 x 36	1	1206576X3	1010,874
76 x 4	120 x 36	1	1206576X4	1010,874
78 x 1,5	120 x 22	1	1206578X15	1010,874
78 x 2	120 x 22	1	1206578X2	1010,874
78 x 3	120 x 36	1	1206578X3	1010,874
78 x 4	120 x 36	1	1206578X4	1010,874
80 x 1,5	120 x 22	1	1206580X15	1010,874
80 x 2	120 x 22	1	1206580X2	1010,874
80 x 3	120 x 36	1	1206580X3	1010,874
80 x 4	120 x 36	1	1206580X4	1010,874
82 x 1,5	130 x 25	1	1206582X15	1267,223
82 x 2	130 x 25	1	1206582X2	1267,223
82 x 3	130 x 36	1	1206582X3	1267,223
82 x 4	130 x 36	1	1206582X4	1267,223

d<sub>1</sub>>M82: a richiesta - on demand

## 12072

### Filire tonde **sinistre** ad imbocco corretto, filettatura metrica ISO a passo fine

Spiral point round dies, metric fine thread / Filières rondes, entrée gun, filetage métrique à pas fin

Cojinetes redondos, entrada corregida, rosca metrica fina /Runde Schneideisen mit schälanschnitt, metrisches DIN-ISO-Feingewinde

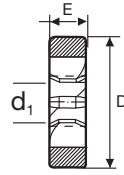

<b>d<sub>1</sub></b>	<b>DxE</b>		<b>cod.</b>	<b>€</b> cad/each
<b>M 3</b> x 0,35	20 x 5	1	1207203X035	37,167
<b>4</b> x 0,5	20 x 5	1	1207204X05	37,167
<b>4,5</b> x 0,5	20 x 5	1	12072045X05	37,167
<b>5</b> x 0,5	20 x 5	1	1207205X05	37,167
<b>5</b> x 0,75	20 x 7	1	1207205X075	37,167
<b>5,5</b> x 0,5	20 x 5	1	12072055X05	37,167
<b>6</b> x 0,5	20 x 5	1	1207206X05	37,167
<b>6</b> x 0,75	20 x 7	1	1207206X075	37,167
<b>7</b> x 0,5	25 x 9	1	1207207X05	39,454
<b>7</b> x 0,75	25 x 9	1	1207207X075	39,454
<b>8</b> x 0,75	25 x 9	1	1207208X075	39,454
<b>8</b> x 1	25 x 9	1	1207208X1	39,454
<b>9</b> x 0,5	25 x 9	1	1207209X05	46,327
<b>10</b> x 1	30 x 11	1	1207210X1	46,327
<b>10</b> x 1,25	30 x 11	1	1207210X125	46,327
<b>12</b> x 1	38 x 10	1	1207212X1	50,229
<b>12</b> x 1,25	38 x 10	1	1207212X125	60,951
<b>12</b> x 1,5	38 x 10	1	1207212X15	58,591
<b>13</b> x 1,5	38 x 10	1	1207213X15	64,605
<b>14</b> x 1	38 x 10	1	1207214X1	64,605
<b>14</b> x 1,25	38 x 10	1	1207214X125	64,605
<b>14</b> x 1,5	38 x 10	1	1207214X15	59,720
<b>15</b> x 1,5	38 x 10	1	1207215X15	92,063
<b>16</b> x 1	45 x 14	1	1207216X1	92,063
<b>16</b> x 1,25	45 x 14	1	1207216X125	92,063
<b>16</b> x 1,5	45 x 14	1	1207216X15	92,063
<b>18</b> x 1	45 x 14	1	1207218X1	100,085
<b>18</b> x 1,25	45 x 14	1	1207218X125	100,085
<b>18</b> x 1,5	45 x 14	1	1207218X15	100,085
<b>18</b> x 2	45 x 14	1	1207218X2	100,085
<b>20</b> x 1,25	45 x 14	1	1207220X125	100,085
<b>20</b> x 1,5	45 x 14	1	1207220X15	100,085
<b>20</b> x 2	45 x 14	1	1207220X2	100,085
<b>22</b> x 1,25	55 x 16	1	1207222X125	151,131
<b>22</b> x 1,5	55 x 16	1	1207222X15	151,131
<b>22</b> x 2	55 x 16	1	1207222X2	151,131
<b>23</b> x 1,5	55 x 16	1	1207223X15	151,131
<b>24</b> x 1,25	55 x 16	1	1207224X125	151,131
<b>24</b> x 1,5	55 x 16	1	1207224X15	151,131
<b>24</b> x 2	55 x 16	1	1207224X2	151,131
<b>25</b> x 1,5	55 x 16	1	1207225X15	151,131
<b>25</b> x 2	55 x 16	1	1207225X2	151,131
<b>26</b> x 1,5	55 x 16	1	1207226X15	188,577
<b>26</b> x 2	55 x 16	1	1207226X2	188,577
<b>27</b> x 1,5	65 x 18	1	1207227X15	188,577
<b>27</b> x 2	65 x 18	1	1207227X2	188,577

<b>d<sub>1</sub></b>	<b>DxE</b>		<b>cod.</b>	<b>€</b> cad/each
<b>28</b> x 1,5	65 x 18	1	1207228X15	188,577
<b>28</b> x 2	65 x 18	1	1207228X2	188,577
<b>30</b> x 1,5	65 x 18	1	1207230X15	269,100
<b>30</b> x 2	65 x 18	1	1207230X2	269,100
<b>30</b> x 2,5	65 x 18	1	1207230X25	269,100
<b>30</b> x 3	65 x 25	1	1207230X3	269,100
<b>32</b> x 1,5	65 x 18	1	1207232X15	269,100
<b>32</b> x 2	65 x 18	1	1207232X2	269,100
<b>32</b> x 3	65 x 25	1	1207232X3	269,100
<b>33</b> x 1,5	65 x 18	1	1207233X15	282,555
<b>33</b> x 2	65 x 18	1	1207233X2	282,555
<b>33</b> x 3	65 x 25	1	1207233X3	282,555
<b>34</b> x 1,5	65 x 18	1	1207234X15	289,800
<b>34</b> x 2	65 x 18	1	1207234X2	289,800
<b>35</b> x 1,5	65 x 18	1	1207235X15	289,800
<b>35</b> x 2	65 x 18	1	1207235X2	289,800
<b>36</b> x 1,5	65 x 18	1	1207236X15	289,800
<b>36</b> x 2	65 x 18	1	1207236X2	289,800
<b>36</b> x 3	65 x 25	1	1207236X3	289,800
<b>37</b> x 1,5	65 x 18	1	1207237X15	329,130
<b>38</b> x 1	75 x 20	1	1207238X1	329,130
<b>38</b> x 1,5	75 x 20	1	1207238X15	329,130
<b>38</b> x 2	75 x 20	1	1207238X2	329,130
<b>38</b> x 3	75 x 30	1	1207238X3	329,130
<b>39</b> x 1,5	75 x 20	1	1207239X15	336,375
<b>39</b> x 2	75 x 20	1	1207239X2	336,375
<b>39</b> x 3	75 x 30	1	1207239X3	336,375
<b>40</b> x 1	75 x 20	1	1207240X1	336,375
<b>40</b> x 1,5	75 x 20	1	1207240X15	336,375
<b>40</b> x 2	75 x 20	1	1207240X2	336,375
<b>40</b> x 3	75 x 30	1	1207240X3	336,375
<b>42</b> x 1	75 x 20	1	1207242X1	341,550
<b>42</b> x 1,5	75 x 20	1	1207242X15	341,550
<b>42</b> x 2	75 x 20	1	1207242X2	341,550
<b>42</b> x 3	75 x 30	1	1207242X3	341,550
<b>44</b> x 1,5	90 x 22	1	1207244X15	428,490
<b>44</b> x 2	90 x 22	1	1207244X2	428,490
<b>45</b> x 1	90 x 22	1	1207245X1	428,490
<b>45</b> x 1,5	90 x 22	1	1207245X15	428,490
<b>45</b> x 2	90 x 22	1	1207245X2	428,490
<b>45</b> x 3	90 x 36	1	1207245X3	465,750
<b>46</b> x 1,5	90 x 22	1	1207246X15	465,750
<b>48</b> x 1	90 x 22	1	1207248X1	481,275
<b>48</b> x 1,5	90 x 22	1	1207248X15	481,275
<b>48</b> x 2	90 x 22	1	1207248X2	481,275
<b>48</b> x 3	90 x 36	1	1207248X3	481,275

d<sub>1</sub>>M48: a richiesta - on demand



# 12146

## Filiere tonde ad imbocco corretto, filettatura metrica ISO a passo fine

Spiral point round dies, metric fine thread / Filières rondes, entrée gun, filetage métrique à pas fin

Cojinetes redondos, entrada corregida, rosca metrica fina /Runde Schneideisen mit schälanschnitt, metrisches DIN-ISO-Feingewinde

**HSS**  
**CO5**

**DIN**  
**223**

**EN**  
**22568**

**MF**

**6g**

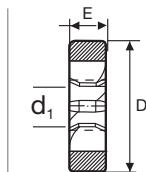

	$d_1$	DxE	pcs 	cod.	€ cad/each
<b>M</b>	6 x 0,75	20 x 7	1	1214606X075	27,303
	8 x 0,75	25 x 9	1	1214608X075	28,970
	8 x 1	25 x 9	1	1214608X1	28,970
	10 x 1	30 x 11	1	1214610X1	34,010
	10 x 1,25	30 x 11	1	1214610X125	38,078
	12 x 1	38 x 10	1	1214612X1	42,880
	12 x 1,25	38 x 10	1	1214612X125	42,880
	12 x 1,5	38 x 10	1	1214612X15	41,131
	14 x 1,25	38 x 10	1	1214614X125	45,364
	14 x 1,5	38 x 10	1	1214614X15	42,031
	16 x 1,5	45 x 14	1	1214616X15	64,615
	18 x 1,5	45 x 14	1	1214618X15	74,768
	18 x 2	45 x 14	1	1214618X2	77,687
	20 x 1,5	45 x 14	1	1214620X15	74,768
	20 x 2	45 x 14	1	1214620X2	77,687
	22 x 1,5	55 x 16	1	1214622X15	128,019
	24 x 1,5	55 x 16	1	1214624X15	128,019



Inox



Acciaio  
Steel



Metals



## 12075

### Filire tonde ad imbocco corretto, filettatura gas cilindrica ISO 228

Spiral point round dies, spiral point, Whitworth pipe thread ISO 228 / Filières rondes, entrée gun, pour filetage gaz de tuyauterie ISO 228

Cojinetes redondos, entrada corregida, rosca gas cilíndrica ISO 228 / Runde Schneideisen mit schälanschnitt für Rohrgewinde DIN-ISO 228

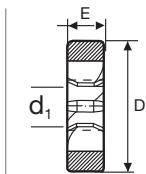

d <sub>1</sub>	DxE	pcs 	cod.	€ cad/each
<b>G</b> 1/8 x 28	30 x 11	1	120751/8	32,044
1/4 x 19	38 x 10	1	120751/4	35,200
3/8 x 19	45 x 14	1	120753/8	50,570
1/2 x 14	45 x 14	1	120751/2	51,771
5/8 x 14	55 x 16	1	120755/8	77,128
3/4 x 14	55 x 16	1	120753/4	113,063
7/8 x 14	65 x 18	1	120757/8	119,781
1" x 11	65 x 18	1	120751"	124,262
1.1/8 x 11	75 x 20	1	120751.1/8	174,636
1.1/4 x 11	75 x 20	1	120751.1/4	174,636
1.3/8 x 11	90 x 22	1	120751.3/8	231,726
1.1/2 x 11	90 x 22	1	120751.1/2	231,726
1.5/8 x 11	90 x 22	1	120751.5/8	240,679
1.3/4 x 11	90 x 22	1	120751.3/4	240,679
1.3/4 x 11	105 x 22	1	120751.3/4105	240,679
2" x 11	90 x 22	1	1207592"	371,658
2" x 11	105 x 22	1	1207512"	371,658
2.1/4 x 11	105 x 22	1	120752.1/4	430,995
2.1/2 x 11	120 x 22	1	120752.1/2	695,178
2.3/4 x 11	120 x 22	1	120752.3/4	1159,200
3" x 11	130 x 25	1	120753"	1293,750
3.1/2 x 11	150 x 25	1	120753.1/2	2111,297
4" x 11	160 x 25	1	120754"	2639,250



# 12148

## Filiere tonde ad imbocco corretto, filettatura gas cilindrica ISO 228

Spiral point round dies, spiral point, Whitworth pipe thread ISO 228 / Filières rondes, entrée gun, pour filetage gaz de tuyauterie ISO 228

Cojinetes redondos, entrada corregida, rosca gas cilíndrica ISO 228 / Runde Schneideisen mit schälanschnitt für Rohrgewinde DIN-ISO 228

<b>HSS</b> CO5	<b>DIN</b> 5158	<b>EN</b> 24231	<b>ISO</b> 228	<b>BSP</b>
-------------------	--------------------	--------------------	-------------------	------------

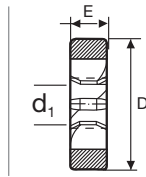

$d_1$	DxE	pcs	cod.	€ cad/each	$d_1$	DxE	pcs	cod.	€ cad/each
<b>G</b> 1/8 x 28	30 x 11	1	121481/8	42,238	<b>M</b> 1/2 x 14	45 x 14	1	121481/2	68,362
1/4 x 19	38 x 10	1	121481/4	47,372	3/4 x 14	55 x 16	1	121483/4	91,504
3/8 x 19	45 x 14	1	121483/8	68,362	1" x 11	65 x 18	1	121481"	147,767

# 12077

<b>HSS</b>	<b>DIN</b> 5158	<b>EN</b> 24231	<b>ISO</b> 228	<b>BSP</b>
------------	--------------------	--------------------	-------------------	------------

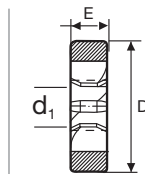

$d_1$	DxE	pcs	cod.	€ cad/each	$d_1$	DxE	pcs	cod.	€ cad/each
<b>G</b> 1/8 x 28	30 x 11	1	120771/8	73,164	<b>G</b> 1.1/8 x 11	75 x 20	1	120771.1/8	274,265
1/4 x 19	38 x 10	1	120771/4	83,918	1.1/4 x 11	75 x 20	1	120771.1/4	274,265
3/8 x 19	45 x 14	1	120773/8	121,499	1.3/8 x 11	90 x 22	1	120771.3/8	447,782
1/2 x 14	45 x 14	1	120771/2	121,499	1.1/2 x 11	90 x 22	1	120771.1/2	447,782
5/8 x 14	55 x 16	1	120775/8	164,565	1.5/8 x 11	90 x 22	1	120771.5/8	447,782
3/4 x 14	55 x 16	1	120773/4	206,265	1.3/4 x 11	105 x 22	1	120771.3/4	776,902
7/8 x 14	65 x 18	1	120777/8	228,373	2" x 11	105 x 22	1	120772"	776,902
1" x 11	65 x 18	1	120771"	228,373					

## 12070

### Filiere tonde ad imbocco corretto, filettatura Whitworth BS-84

Round dies, spiral point, Whitworth BSW thread BS-84 / Filières rondes, entrée gun, filetage Whitworth

Cojinetes redondos, entrada corregida, rosca Whitworth / Runde Schneideisen mit schälanschnitt, Whitworth –Gewinde BS-84

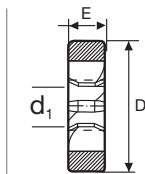
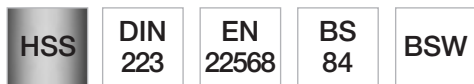

$d_1$	DxE	pcs 	cod.	€ cad/each
<b>BSW</b> 1/16 x 60	16 x 5	1	120701/16	37,560
3/32 x 48	16 x 5	1	120703/32	37,560
1/8 x 40	20 x 5	1	120701/8	27,407
5/32 x 32	20 x 5	1	120705/32	25,772
3/16 x 24	20 x 7	1	120703/16	25,772
7/32 x 24	20 x 7	1	120707/32	25,772
1/4 x 20	25 x 9	1	120701/4	25,772
5/16 x 18	20 x 7	1	120705/16	28,349
3/8 x 16	30 x 11	1	120703/8	35,635
7/16 x 14	30 x 11	1	120707/16	35,635
1/2 x 12	38 x 14	1	120701/2	39,340
9/16 x 12	38 x 14	1	120709/16	57,494
5/8 x 11	45 x 18	1	120705/8	57,494
3/4 x 10	45 x 18	1	120703/4	64,015
7/8 x 9	55 x 22	1	120707/8	87,954
1" x 8	55 x 22	1	120701"	92,570
1.1/8 x 7	65 x 25	1	120701.1/8	123,144
1.1/4 x 7	65 x 25	1	120701.1/4	123,144
1.3/8 x 6	65 x 25	1	120701.3/8	176,871
1.1/2 x 6	65 x 22	1	1207061.1/2	219,410
1.1/2 x 6	75 x 30	1	1207071.1/2	383,405
1.5/8 x 5	75 x 30	1	120701.5/8	258,595
1.3/4 x 5	90 x 36	1	120701.3/4	355,874
1.7/8 x 4,5	90 x 36	1	120701.7/8	355,874
2" x 4,5	90 x 36	1	120702"	355,874
2.1/4 x 4	105 x 36	1	120702.1/4	1087,837
2.1/2 x 4	105 x 36	1	120702.1/2	1087,837
2.3/4 x 3,5	120 x 36	1	120702.3/4	1336,485
3" x 3,5	120 x 36	1	120703"	1336,485



Acciaio  
Steel

Metals

# 12088

## Filire tonde ad imbocco corretto, filettatura Whitworth BS-84

Round dies, spiral point, Whitworth thread BS-84 / Filières rondes, entrée gun, filetage Whitworth

Cojinetes redondos, entrada corregida, rosca Whitworth / Runde Schneideisen mit schälanschnitt, Whitworth –Gewinde BS-84

HSS DIN 223 EN 22568 BS 84 BSW

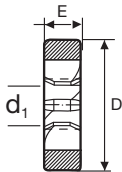

$d_1$	DxE	pcs 	cod.	€ cad/each
<b>BSW</b> 1/8 x 40	20 x 5	1	120881/8	46,627
5/32 x 32	20 x 5	1	120885/32	46,627
3/16 x 24	20 x 7	1	120883/16	46,627
1/4 x 20	20 x 7	1	120881/4	46,627
5/16 x 18	25 x 9	1	120885/16	52,133
3/8 x 16	30 x 11	1	120883/8	60,868
7/16 x 14	30 x 11	1	120887/16	66,799

$d_1$	DxE	pcs 	cod.	€ cad/each
<b>BSW</b> 1/2 x 12	38 x 14	1	120881/2	100,416
9/16 x 12	38 x 14	1	120889/16	100,416
5/8 x 11	45 x 18	1	120885/8	127,802
3/4 x 10	45 x 18	1	120883/4	127,802
7/8 x 9	55 x 22	1	120887/8	185,617
1" x 8	55 x 22	1	120881"	185,617

# 12087

HSS DIN 223 EN 22568 BS 84 BSF

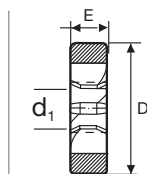

$d_1$	DxE	pcs 	cod.	€ cad/each
<b>BSF</b> 3/16 x 32	20 x 7	1	120873/16	32,934
1/4 x 26	25 x 9	1	120871/4	36,815
5/16 x 22	25 x 9	1	120875/16	36,815
3/8 x 20	30 x 11	1	120873/8	44,950
7/16 x 18	30 x 11	1	120877/16	44,950
1/2 x 16	38 x 10	1	120871/2	52,381

$d_1$	DxE	pcs 	cod.	€ cad/each
<b>BSF</b> 9/16 x 16	38 x 10	1	120879/16	56,904
5/8 x 14	45 x 14	1	120875/8	71,839
3/4 x 12	45 x 14	1	120873/4	75,255
7/8 x 11	55 x 22	1	120877/8	119,781
1" x 10	55 x 22	1	120871"	119,781







## 12080

Filiere tonde ad imbocco corretto, fil. americana UNC passo grosso ANSI B1.1

Round dies, spiral point, unified coarse thread UNC / Filières rondes, filetage américain à pas gros UNC

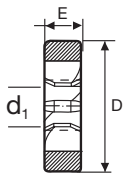
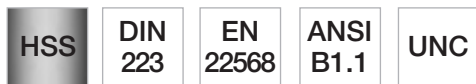
Cojinetes redondos, rosca unificada vasta UNC / Runde Schneideisen, amerikanisches grossgewinde UNC



	d <sub>1</sub>	DxE	pcs 	cod.	€ cad/each
<b>N° 1</b>	x 64	16 x 5	1	12080N01	46,627
<b>2</b>	x 56	16 x 5	1	12080N02	46,627
<b>3</b>	x 48	16 x 5	1	12080N03	46,627
<b>4</b>	x 40	20 x 5	1	12080N04	34,186
<b>5</b>	x 40	20 x 5	1	12080N05	29,601
<b>6</b>	x 32	20 x 7	1	12080N06	29,601
<b>8</b>	x 32	20 x 7	1	12080N08	29,601
<b>10</b>	x 24	20 x 7	1	12080N10	29,601
<b>12</b>	x 24	20 x 7	1	12080N12	29,601
<b>UNC 1/4</b>	x 20	20 x 7	1	120801/4	27,096
<b>5/16</b>	x 18	25 x 9	1	120805/16	30,191
<b>3/8</b>	x 16	30 x 11	1	120803/8	37,208
<b>7/16</b>	x 14	30 x 11	1	120807/16	37,208
<b>1/2</b>	x 13	38 x 14	1	120801/2	43,211
<b>9/16</b>	x 12	38 x 14	1	120809/16	47,144
<b>5/8</b>	x 11	45 x 18	1	120805/8	59,295
<b>3/4</b>	x 10	45 x 18	1	120803/4	62,245
<b>7/8</b>	x 9	55 x 22	1	120807/8	87,333
<b>1"</b>	x 8	55 x 22	1	120801"	90,293
<b>1.1/8</b>	x 7	65 x 25	1	120801.1/8	130,979
<b>1.1/4</b>	x 7	65 x 25	1	120801.1/4	130,979
<b>1.3/8</b>	x 6	65 x 25	1	120801.3/8	130,979
<b>1.1/2</b>	x 6	65 x 25	1	1208061.1/2	278,746
<b>1.1/2</b>	x 6	75 x 30	1	1208071.1/2	278,746
<b>1.5/8</b>	x 5	75 x 30	1	120801.5/8	278,746
<b>1.3/4</b>	x 5	90 x 36	1	120801.3/4	373,894
<b>1.7/8</b>	x 4,5	90 x 36	1	120801.7/8	373,894
<b>2"</b>	x 4,5	90 x 36	1	120802"	463,680



Acciaio  
Steel

Metals

# 12082

## Filieri tonde **sinistre** a imbocco corretto, filettatura americana UNC

Spiral point round dies, spiral point, Whitworth pipe thread ISO 228 / Filières rondes, entrée gun, pour filetage gaz de tuyauterie ISO 228

Cojinetes redondos, entrada corregida, rosca gas cilíndrica ISO 228 / Runde Schneideisen mit schälanschnitt für Rohrgewinde DIN-ISO 228

HSS

DIN  
223

EN  
22568

ANSI  
B1.1

UNC

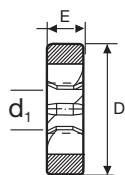

d <sub>1</sub>	DxE	pcs 	cod.	€ cad/each
<b>N° 6</b> x 32	20 x 7	1	12082NR06	<a href="#">51,678</a>
<b>8</b> x 32	20 x 7	1	12082NR08	<a href="#">51,678</a>
<b>10</b> x 24	20 x 7	1	12082NR10	<a href="#">51,678</a>
<b>UNC 1/4</b> x 20	20 x 7	1	120821/4	<a href="#">42,269</a>
<b>5/16</b> x 18	25 x 9	1	120825/16	<a href="#">50,104</a>
<b>3/8</b> x 16	30 x 11	1	120823/8	<a href="#">59,440</a>
<b>7/16</b> x 14	38 x 14	1	120827/16	<a href="#">59,440</a>
<b>1/2</b> x 13	38 x 14	1	120821/2	<a href="#">93,926</a>
<b>9/16</b> x 12	38 x 14	1	120829/16	<a href="#">93,926</a>
<b>5/8</b> x 11	45 x 18	1	120825/8	<a href="#">118,942</a>
<b>3/4</b> x 10	45 x 18	1	120823/4	<a href="#">118,942</a>
<b>7/8</b> x 9	55 x 22	1	120827/8	<a href="#">172,183</a>
<b>1"</b> x 8	55 x 22	1	120821"	<a href="#">172,183</a>



Acciaio  
Steel



Metals



## 12085

### Filire tonde, filettatura Americana UNF a passo fine ANSI B1.1

Round dies, unified fine thread UNF / Filières rondes, filetage américain à pas fin

Cojinetes redondos, rosca unificada fina UNF / Runde Schneideisen, amerikanisches fein-Gewinde

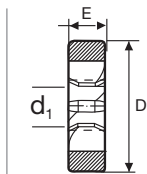
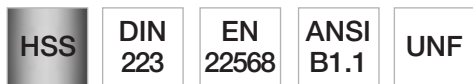

	d <sub>1</sub>	DxE	pcs 	cod.	€ cad/each
<b>N° 1</b>	x 72	16 x 5	1	12085N01	46,627
<b>2</b>	x 64	16 x 5	1	12085N02	39,910
<b>3</b>	x 56	16 x 5	1	12085N03	36,494
<b>4</b>	x 48	20 x 5	1	12085N04	34,207
<b>5</b>	x 44	20 x 5	1	12085N05	31,930
<b>6</b>	x 40	20 x 5	1	12085N06	29,601
<b>8</b>	x 36	20 x 7	1	12085N08	29,601
<b>10</b>	x 32	20 x 7	1	12085N10	29,601
<b>12</b>	x 28	20 x 7	1	12085N12	29,601
<b>UNF 1/4</b>	x 28	20 x 7	1	120851/4	27,096
<b>5/16</b>	x 24	25 x 9	1	120855/16	30,191
<b>3/8</b>	x 24	30 x 11	1	120853/8	37,208
<b>7/16</b>	x 20	30 x 11	1	120857/16	37,208
<b>1/2</b>	x 20	38 x 10	1	120851/2	43,211
<b>9/16</b>	x 18	38 x 10	1	120859/16	47,144
<b>5/8</b>	x 18	45 x 14	1	120855/8	62,121
<b>3/4</b>	x 16	45 x 14	1	120853/4	65,205
<b>7/8</b>	x 14	55 x 16	1	120857/8	87,333
<b>1"</b>	x 12	55 x 16	1	120851"X12	90,293
<b>1"</b>	x 14	55 x 16	1	120851"X14	108,002
<b>1.1/8</b>	x 12	65 x 18	1	120851.1/8	136,579
<b>1.1/4</b>	x 12	65 x 18	1	120851.1/4	136,579
<b>1.3/8</b>	x 12	65 x 18	1	120851.3/8	136,579
<b>1.1/2</b>	x 12	65 x 18	1	1208561.1/2	306,733
<b>1.1/2</b>	x 12	75 x 20	1	1208571.1/2	306,733



# 12086

## Filiere tonde, filettatura Americana ANSI B1.1

Round dies, unified fine thread / Filières rondes, filetage américain

Cojinetes redondos, rosca unificada fina / Runde Schneideisen, amerikanisches

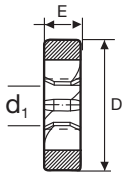

$d_1$	DxE	pcs 	cod.	€ cad/each
N° 10 x 32	20 x 7	1	12086NR10	53,924
<b>UNC 1/4</b> x 28	20 x 7	1	120861/4	44,101
5/16 x 24	25 x 9	1	120865/16	52,288
3/8 x 24	30 x 11	1	120863/8	62,028
7/16 x 20	30 x 11	1	120867/16	62,028
1/2 x 20	38 x 10	1	120861/2	98,015

$d_1$	DxE	pcs 	cod.	€ cad/each
<b>UNC 9/16</b> x 18	38 x 10	1	120869/16	98,015
5/8 x 18	45 x 14	1	120865/8	124,107
3/4 x 16	45 x 14	1	120863/4	124,107
7/8 x 14	55 x 16	1	120867/8	179,676
1" x 12	55 x 16	1	120861"	179,676

# 12079

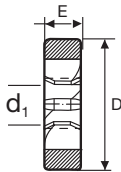

$d_1$	DxE	pcs 	cod.	€ cad/each
<b>UNEF 1/4</b> x 32	20 x 7	1	120791/4	47,341
3/8 x 32	30 x 11	1	120793/8	68,859
1/2 x 28	38 x 10	1	120791/2	103,283
9/16 x 24	38 x 10	1	120799/16	103,283
5/8 x 24	45 x 14	1	120795/8	164,317
3/4 x 20	45 x 14	1	120793/4	164,317

$d_1$	DxE	pcs 	cod.	€ cad/each
<b>UNEF 7/8</b> x 20	55 x 16	1	120797/8	193,659
1" x 20	55 x 16	1	120791"	193,659
1.1/8 x 18	65 x 18	1	120791.1/8	309,858
1.1/4 x 18	65 x 18	1	120791.1/4	309,858
1.1/2 x 18	75 x 20	1	120791.1/2	387,318



## 12091

### Filiere tonde, filettatura conica americana per tubi 1:16 NPT

Round dies, taper pipe thread NPT / Filières rondes, filetage conique pour tubes NPT

Cojinetes redondos, rosca conica americana NPT / Runde Schneideisen, amerikanisches kegeliges Rohrgewinde NPT



CONICITA' 1:16  
TAPER 1:16



d <sub>1</sub>	DxE	pcs 	cod.	€ cad/each
1/8 x 27	30 x 11	1	120911/8	57,763
1/4 x 18	38 x 14	1	120911/4	63,653
3/8 x 18	45 x 18	1	120913/8	82,386
1/2 x 14	45 x 18	1	120911/2	126,498
3/4 x 14	55 x 22	1	120913/4	138,814
1" x 11,5	65 x 25	1	120911"	198,140
1.1/4 x 11,5	75 x 26	1	120911.1/4	386,210
1.1/2 x 11,5	90 x 27	1	120911.1/2	660,475
2" x 11,5	105 x 28	1	120912"	996,312



Acciaio  
Steel



Metals



# 12089

## Filiere tonde, filettatura conica per tubi 1:16 BSPT

Round dies, Whitworth taper thread 1:16 BSPT / Filières rondes, filetage gaz de tuyauterie BSPT

Cojinetes redondos, rosca gas conica BSPT / Runde Schneideisen, britisches kegeliges Rohrgewinde BSPT



CONICITA' 1:16  
TAPER 1:16



	d <sub>1</sub>	DxE	pcs 	cod.	€ cad/each
<b>Rc</b>	1/8 x 28	30 x 11	1	120891/8	<a href="#">57,763</a>
	1/4 x 19	38 x 14	1	120891/4	<a href="#">63,653</a>
	3/8 x 19	45 x 18	1	120893/8	<a href="#">82,386</a>
	1/2 x 14	45 x 18	1	120891/2	<a href="#">126,498</a>
	3/4 x 14	55 x 22	1	120893/4	<a href="#">138,814</a>
	1" x 11	65 x 25	1	120891"	<a href="#">198,140</a>
	1.1/4 x 11	75 x 26	1	120891.1/4	<a href="#">386,210</a>
	1.1/2 x 11	90 x 27	1	120891.1/2	<a href="#">660,475</a>
	2" x 11	105 x 28	1	120892"	<a href="#">996,312</a>



## 15001

### Giramaschi estensibili, modello americano

Adjustable tap wrenches / Tourne à gauche extensible

Giramachos ajustables / Verstellbare Windeisen

**DIN  
1814**

**Lega leggera**  
Light alloy

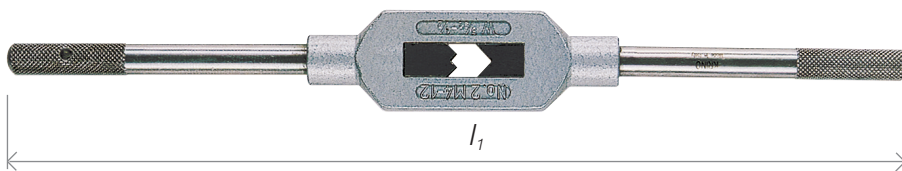

Gr. N.	Per maschi for taps		$l_1$	cod.	€ cad/each
	M	BSW BSP			
0	1 ÷ 8	1/16 ÷ 1/4	130	1500100	9,594
1	1 ÷ 10	1/16 ÷ 3/8	180	1500101	10,298
1.1/2	1 ÷ 12	1/16 ÷ 1/2	180	1500101.1/2	11,871
2	4 ÷ 12	5/32 ÷ 1/2	280	1500102	16,570
3	5 ÷ 20	7/32 ÷ 3/4	380	1500103	25,523
4	11 ÷ 27	7/16 ÷ 1"	500	1500104	40,303
5	13 ÷ 32	1/2 ÷ 1.1/4	700	1500105	82,841
*6	18 ÷ 42	3/4 ÷ 1.1/2	780	1500106	181,125
*7	25 ÷ 52	1" ÷ 2.1/8	800	1500107	197,023
*8	25 ÷ 64	1" ÷ 2.1/2	1200	1500108	442,183

\* corpo in acciaio / steel

## 15003

**DIN  
1814**

**Acciaio**  
Steel

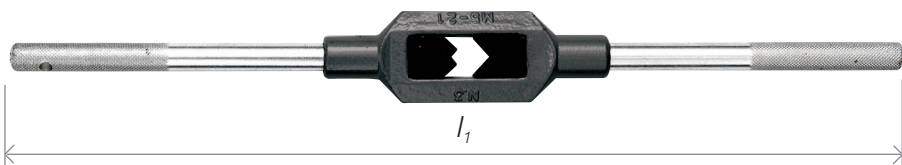

Gr. N.	Per maschi for taps		$l_1$	cod.	€ cad/each
	M	BSW BSP			
0	1 ÷ 8	1/16 ÷ 1/4	170	1500300	15,670
1	1 ÷ 10	1/16 ÷ 3/8	200	1500301	16,788
1.1/2	1 ÷ 12	1/16 ÷ 1/2	200	1500301.1/2	19,034
2	4 ÷ 12	5/32 ÷ 1/2	260	1500302	24,633
3	5 ÷ 20	7/32 ÷ 3/4	345	1500303	40,303
4	11 ÷ 27	7/16 ÷ 1"	430	1500304	64,926
5	13 ÷ 32	1/2 ÷ 1.1/4	770	1500305	102,993
6	18 ÷ 42	3/4 ÷ 1.1/2	870	1500306	191,475
7	25 ÷ 52	1" ÷ 2.1/8	1000	1500307	204,930
8	25 ÷ 64	1" ÷ 2.1/2	1200	1500308	442,183

# 15010

## Giramaschi a cricchetto reversibile

Tap holder with ratchet / Porte-tarands à cliquet

Giramachos de carraca / Werkzeugehalter mit knarre



**Serie corta**  
Short serie





Gr. N.	Per maschi M	for taps BSW	$l_1$	pcs 	cod.	€ cad/each
1	3 ÷ 10	1/8 ÷ 3/8	85	1	1501001	15,028
2	5 ÷ 12	7/32 ÷ 1/2	100	1	1501002	18,102

# 15011

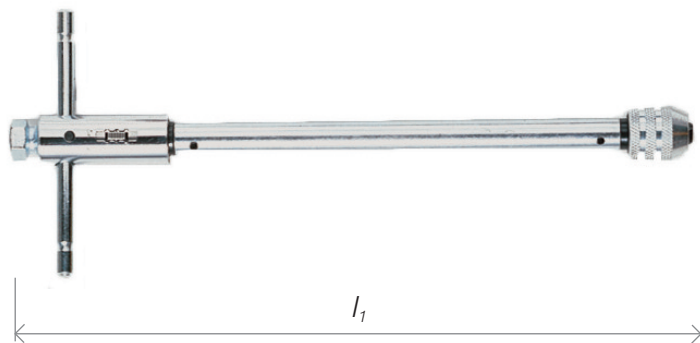

**Serie lunga**  
Long serie



Gr. N.	Per maschi M	for taps BSW	$l_1$	pcs 	cod.	€ cad/each
1	3 ÷ 10	1/8 ÷ 3/8	250	1	1501101	21,538
2	5 ÷ 12	7/32 ÷ 1/2	300	1	1501102	27,107



## 15030

### Portafiliera per filiere tonde

Round-die stock / Porte filières à main

Manerales para cojinetes / Schneideisenhalter

DIN  
225

EN  
22568

Leggera - Light alloy  
In pollici - inches

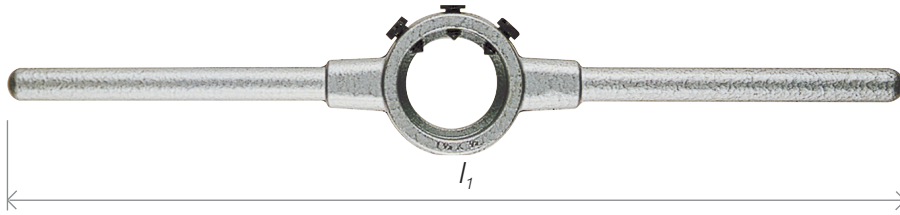

Gr. N.	d <sub>1</sub> mm	d <sub>1</sub> pollici/inches	l <sub>1</sub>	pcs 	cod.	€ cad/each
0	20,6 x 6,35	13/16 x 1/4	185	1	1503000	7,504
1	25,4 x 9,5	1" x 3/8	215	1	1503001	7,835
2/A	33,4 x 11,1	1.5/16 x 7/16	265	1	1503002/A	13,662
2	38,1 x 12,7	1.1/2 x 1/2	310	1	1503002	13,662
3	50,8 x 15,9	2" x 5/8	485	1	1503003	28,545
4	63,5 x 19	2.1/2 x 3/4	630	1	1503004	44,215
*5	76,2 x 22	3" x 7/8	700	1	1503005	107,464
*6	88,9 x 25,4	3.1/2 x 1"	940	1	1503006	196,464
*7	101,6 x 25,4	4" x 1"	980	1	1503007	615,825

\* Acciaio - Steel

# 15035

## Portafiliera per filiere tonde

Round-die stock / Porte filières à main

Manerales para cojinetes / Schneideisenhalter

DIN  
225

EN  
22568

Leggera - light alloy  
Per filiere DIN 223 - for dies DIN 223

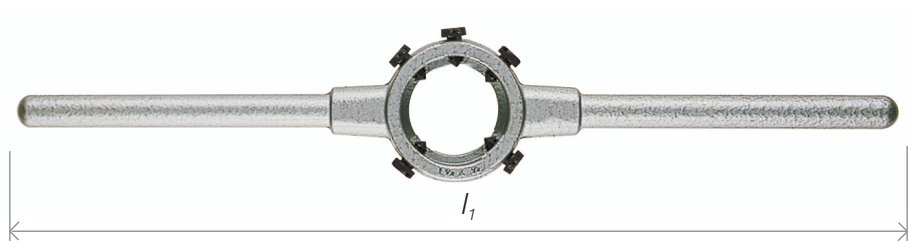

Gr. N.	M	BSW BSP	$l_1$	pcs 	cod.	€ cad/each
16 x 5	M 1 ÷ 2,6	W 1/16 ÷ 3/32	160	1	1503516X5	6,603
20 x 5	M 3 ÷ 4	W 1/8 ÷ 5/32	185	1	1503520X5	6,945
20 x 7	M 4,5 ÷ 6	W 3/16 ÷ 1/4	185	1	1503520X7	6,945
25 x 9	M 7 ÷ 9	W 5/16	215	1	1503525X9	7,504
30 x 11	M 10 ÷ 11	W 3/8 ÷ 7/16	265	1	1503530X11	11,644
38 x 10	MF 12 ÷ 14	G 1/8 ÷ 1/4	315	1	1503538X10	12,875
38 x 14	M 12 ÷ 14	W 1/2 ÷ 9/16	315	1	1503538X14	12,875
45 x 14	MF 16 ÷ 20	G 3/8 ÷ 1/2	450	1	1503545X14	20,379
45 x 18	M 16 ÷ 20	W 5/8 ÷ 13/16	450	1	1503545X18	20,379
55 x 16	MF 22 ÷ 24	G 5/8 ÷ 3/4	560	1	1503555X16	31,350
55 x 22	M 22 ÷ 24	W 7/8 ÷ 1"	560	1	1503555X22	31,350
65 x 18	MF 26 ÷ 35	G 7/8 ÷ 1"	630	1	1503565X18	45,002
65 x 25	M 27 ÷ 36	W 1"1/8 ÷ 1"3/8	630	1	1503565X25	45,002
*75 x 20	MF 38 ÷ 42	G 1"1/8 ÷ 1"1/4	710	1	1503575X20	107,464
*75 x 30	M 39 ÷ 42	W 1"1/2 ÷ 1"5/8	710	1	1503575X30	115,206
*90 x 22	MF 45 ÷ 52	G 1"3/8 ÷ 1"3/4	920	1	1503590X22	214,328
*90 x 36	M 45 ÷ 52	W 1"3/4 ÷ 2"	920	1	1503590X36	214,328

\* Acciaio - Steel

## 15032

### Portafiliera per filiere tonde

Round-die stock / Porte filières à main

Manerales para cojinetes / Schneideisenhalter

DIN  
225

EN  
22568

Acciaio - steel  
In pollici - inches



Gr. N.	d <sub>1</sub> mm	d <sub>1</sub> pollici/inches	l <sub>1</sub>	pcs 	cod.	€ cad/each
1	25,4 x 9,5	1" x 3/8	210	1	1503201	19,593
2	38,1 x 12,7	1"1/2 x 1/2	300	1	1503202	23,784
3	50,8 x 15,9	2" x 5/8	490	1	1503203	36,380
4	63,5 x 19	2.1/2 x 3/4	520	1	1503204	62,100
5	76,2 x 22	3" x 7/8	700	1	1503205	119,025
6	88,9 x 25,4	3.1/2 x 1"	950	1	1503206	224,595
7	101,6 x 25,4	4" x 1"	890	1	1503207	676,890

# 15037

## Portafiliera per filiere tonde

Round-die stock / Porte filières à main

Manerales para cojinetes / Schneideisenhalter

DIN  
225

EN  
22568

Acciaio - steel  
Per filiere DIN 223 - for dies DIN 223

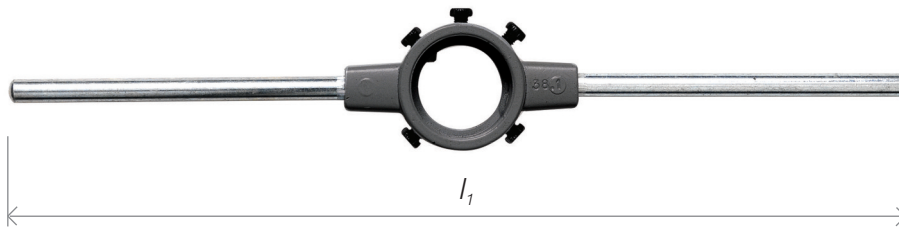

Gr. N.	M	BSW BSP	$l_1$	pcs 	cod.	€ cad/each
16 x 5	M 1 ÷ 2,6	W 1/16 ÷ 3/32	160	1	1503716X5	13,434
20 x 5	M 3 ÷ 4	W 1/8 ÷ 5/32	190	1	1503720X5	16,125
20 x 7	M 4,5 ÷ 6	W 3/16 ÷ 1/4	190	1	1503720X7	16,125
25 x 9	M 7 ÷ 9	W 5/16	215	1	1503725X9	18,806
30 x 11	M 10 ÷ 11	W 3/8 ÷ 7/16	250	1	1503730X11	18,806
38 x 10	MF 12 ÷ 14	G 1/8 ÷ 1/4	310	1	1503738X10	21,497
38 x 14	M 12 ÷ 14	W 1/2 ÷ 9/16	310	1	1503738X14	21,497
45 x 14	MF 16 ÷ 20	G 3/8 ÷ 1/2	445	1	1503745X14	28,214
45 x 18	M 16 ÷ 20	W 5/8 ÷ 13/16	445	1	1503745X18	28,214
55 x 16	MF 22 ÷ 24	G 5/8 ÷ 3/4	495	1	1503755X16	34,931
55 x 22	M 22 ÷ 24	W 7/8 ÷ 1"	495	1	1503755X22	34,931
65 x 18	MF 26 ÷ 35	G 7/8 ÷ 1"	550	1	1503765X18	63,135
65 x 25	M 27 ÷ 36	W 1.1/8 ÷ 1"3/8	550	1	1503765X25	63,135
75 x 20	MF 38 ÷ 42	G 1.1/8 ÷ 1"1/4	735	1	1503775X20	119,449
75 x 30	M 39 ÷ 42	W 1.1/2 ÷ 1"5/8	735	1	1503775X30	119,449
90 x 22	MF 45 ÷ 52	G 1.3/8 ÷ 1"3/4	900	1	1503790X22	223,001
90 x 36	M 45 ÷ 52	W 1.3/4 ÷ 2"	900	1	1503790X36	223,001
105 x 22	MF 54 ÷ 65	G 2" ÷ 2"1/4	980	1	15037105X22	340,370
105 x 36	M 56 ÷ 64	W 2" ÷ 2"1/4	980	1	15037105X36	340,370
120 x 22	MF 64 ÷ 71	G 2.1/4 ÷ 2.3/4	960	1	15037120X22	880,268
120 x 36	M 64 ÷ 71	BSW 2.1/2 ÷ 2.3/4	960	1	15037120X36	880,268
130 x 25		G 3"	960	1	15037130X25	1224,550
130 x 36			960	1	15037130X36	1224,550
140 x 22			980	1	15037140X22	1537,534
150 x 25		G 3.1/2	1000	1	15037150X25	1748,798
160 x 25		G 4"	1000	1	15037160X25	2398,240

## 17020

### Assortimenti a filettare in HSS-G per l'industria in cassetta metallica

HSS-G threading sets in metal case / Assortiments à fileter HSS-G en coffret métallique





Juegos de utensilios a roscar HSS-G en caja metálica / Gewindebohrersätze HSS-G in Metalkassette



Metal







Metal

		
DIN 352 3 pcs	Ø 25	N° 1.1/2
M 3-4-5-6-8-10-12		
		25x9







30 pcs - M 3÷12 HSS-G

**17020501** € 179,117

			
DIN 352 3 pcs	DIN 223	N° 1-3	
M 3-4-5-6-8-10-12-14-16-18-20			
		20x5-20x7-25x9 30x11-38x14-45x18	N° 1 - N° 2

54 pcs - M 3÷20 HSS-G

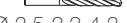
**17020503** € 666,074

		
DIN 352 3 pcs	DIN 223	N° 1-2
M 3-4-5-6-8-10-12		
		20x5-20x7-25x9 30x11-38x14
		
		Ø 2,5-3,3-4,2-5 6,8-8,5-10,25
		
		N° 1

43 pcs - M 3÷12 HSS-G

**17020500** € 307,850

# 17020





## Assortimenti a filetare in HSS-G per l'industria in cassetta di legno

HSS-G threading sets / Assortiments à fileter HSS-G

Juegos de utensilios a roscar HSS-G / Gewindebohrersätze HSS-G







Legno - Wood

 DIN 352 3 pcs	 DIN 223	 N° 1-4
M 3-4-5-6-8-10-12 14-16-18-20-22-24		 20x5-20x7-25x9 30x11-38x14 45x18-55x22
<b>M 3÷24 HSS-G</b>		





17020504

€ 1337,748

 M 3 pcs	 DIN 223	 N° 1-3
MF 2 pcs		 20x7-25x9-30x11 38x14-45x18
M 3x0,5-4x0,7-5x0,8-6x1 -7x1-8x1 8x1,25-10x1,25 -10x1,5-12x1,25 12x1,5 -12x1,75-14x1,25-14x1,5 14x2-16x1,5-16x2		 N° 1
<b>M + MF 3÷16 HSS-G</b>		





17025512

€ 1001,911

 DIN 352 3 pcs	 DIN 223	 N° 1-3-5
M 5-6-8-10-12-14-16 18-20-22-24-27-30		 20x7-25x9 30x11-38x14 45x18-55x22-65x25
<b>M 5÷30 HSS-G</b>		

17020505

€ 2731,469

 M 3 pcs	 DIN 223	 N° 1-3
MF 2 pcs		 25x9-38x14
M 2x0,4-3x0,5-4x0,7-5x0,8-6x1-7x1 8x1-8x1,25-10x1-10x1,25-10x1,5 12x1,25-12x1,5-12x1,75-14x1,25 14x1,5-14x2-16x1,5-16x2-18x1,5		 N° 1
<b>M + MF 2÷18 HSS-G</b>		

17025511

€ 1052,285

## 10600

### Kit per il ripristino delle filettature danneggiate

Thread repair kit / Trousse pour rétablir taraudages endommagés

Juego para reparar rosca dañada / Gewinde-reparatur-Sätze







Metal



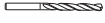



Metal

M

					1,5 d	cod.	€		
				pcs			cad/each		
<b>M 2</b>	x 0,4	2,1 mm	N° 2	N° 2	20	10600098	<b>37,539</b>		
<b>2,5</b>	x 0,45	2,6 mm	3	3	20	10600099	<b>37,539</b>		
<b>3</b>	x 0,5	3,2 mm	4	4	20	10600100	<b>37,539</b>		
<b>3,5</b>	x 0,6	3,7 mm	5	5	20	10600101	<b>37,539</b>		
<b>4</b>	x 0,7	4,2 mm	6	6	20	10600102	<b>37,539</b>		
<b>5</b>	x 0,8	5,2 mm	8	8	20	10600103	<b>36,970</b>		
<b>6</b>	x 1	6,3 mm	9	9	20	10600104	<b>39,785</b>		
<b>7</b>	x 1	7,3 mm	10	11	20	10600105	<b>44,929</b>		
<b>8</b>	x 1,25	8,3 mm	11	11	20	10600106	<b>44,929</b>		
<b>8</b>	x 1	8,3 mm	11	11	20	10600107	<b>44,929</b>		
<b>9</b>	x 1,25	9,3 mm	12	12	15	10600108	<b>56,159</b>		
<b>10</b>	x 1,5	10,4 mm	13	13	15	10600109	<b>54,275</b>		
<b>10</b>	x 1,25	10,3 mm	13	13	15	10600110	<b>54,275</b>		
<b>10</b>	x 1	10,3 mm	13	13	15	10600111	<b>54,275</b>		
<b>11</b>	x 1,5	11,4 mm	14	14	10	10600112	<b>60,817</b>		
<b>12</b>	x 1,75	12,4 mm	15	15	10	10600113	<b>60,817</b>		
<b>12</b>	x 1,5	12,4 mm	15	15	10	10600114	<b>60,817</b>		
<b>12</b>	x 1,25	12,3 mm	15	15	10	10600115	<b>60,817</b>		
<b>12</b>	x 1	12,3 mm	15	15	10	10600116	<b>60,817</b>		
<b>14</b>	x 2		16		10	10600117	<b>64,087</b>		
<b>14</b>	x 1,5		16		10	10600118	<b>64,087</b>		
<b>14</b>	x 1,25		17		10	10600119	<b>64,087</b>		
<b>14</b>	x 1		17		10	10600120	<b>64,087</b>		
<b>16</b>	x 2		18		10	10600121	<b>77,646</b>		
<b>16</b>	x 1,5		18		10	10600122	<b>77,646</b>		
<b>18</b>	x 2,5		20		5	10600123	<b>92,871</b>		
<b>18</b>	x 2		20		5	10600124	<b>92,871</b>		
<b>18</b>	x 1,5		20		5	10600125	<b>92,871</b>		
<b>20</b>	x 2,5		21		5	10600126	<b>99,722</b>		
<b>20</b>	x 2		21		5	10600127	<b>99,722</b>		
<b>20</b>	x 1,5		21		5	10600128	<b>99,722</b>		
<b>22</b>	x 2,5		22		5	10600129	<b>121,706</b>		
<b>22</b>	x 2		22		5	10600130	<b>121,706</b>		
<b>22</b>	x 1,5		22		5	10600131	<b>121,706</b>		
<b>24</b>	x 3		23		5	10600132	<b>140,243</b>		
<b>24</b>	x 2		23		5	10600133	<b>140,243</b>		
<b>24</b>	x 1,5		23		5	10600134	<b>140,243</b>		

M

					1,5 d	cod.	€		
				pcs			cad/each		
<b>M 26</b>	x 1,5			1	10	10600135	<b>422,622</b>		
<b>27</b>	x 3			1	10	10600136	<b>422,622</b>		
<b>27</b>	x 2			1	10	10600137	<b>422,622</b>		
<b>27</b>	x 1,5			1	10	10600138	<b>422,622</b>		
<b>28</b>	x 1,5			1	10	10600139	<b>490,590</b>		
<b>30</b>	x 3,5			1	10	10600140	<b>516,206</b>		
<b>30</b>	x 2			1	10	10600141	<b>516,206</b>		
<b>30</b>	x 1,5			1	10	10600142	<b>516,206</b>		
<b>33</b>	x 3,5			1	10	10600143	<b>538,862</b>		
<b>33</b>	x 2			1	10	10600144	<b>538,862</b>		
<b>36</b>	x 4			1	10	10600145	<b>586,152</b>		
<b>36</b>	x 3			1	10	10600146	<b>586,152</b>		
<b>36</b>	x 2			1	10	10600147	<b>586,152</b>		
<b>36</b>	x 1,5			1	10	10600148	<b>586,152</b>		

Filetto danneggiato  
Damaged thread

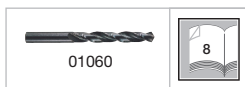
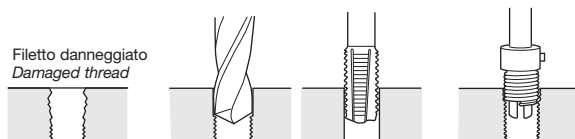

01060

8

# 10605

## Kit per il ripristino delle filettature danneggiate





Thread repair kit / Trousse pour rétablir taraudages endommagés

Juego para reparar rosca dañada - Gewinde-reparatur-Sätze



Metal

M

					cod.	€
				pcs		cad/each
<b>M 5 - M 12</b>						
5 x 0,8	5,2 mm	N° 8	N° 8	25	10605100	238,267
6 x 1	6,3 mm	9	9	25		
8 x 1,25	8,3 mm	11	11	25		
10 x 1,5	10,4 mm	13	13	25		
12 x 1,75	12,4 mm	15	15	10		

<b>M 6 - M 14 x 1,25</b>						
6 x 1	6,3 mm	N° 9	N° 9	25	10605101	267,941
8 x 1,25	8,3 mm	11	11	25		
10 x 1,5	10,4 mm	13	13	25		
12 x 1,75	12,4 mm	15	15	10		
14 x 1,25		17		10		

<b>M 6 - M 14 x 1,25</b>						
6 x 1	6,3 mm	N° 9	N° 9	25	10605102	276,324
8 x 1,25	8,3 mm	11	11	25		
10 x 1,5	10,4 mm	13	13	25		
12 x 1,75	12,4 mm	15	15	10		
*14 x 1,25		17		10		



<b>M 6 - M 10</b>						
6 x 1	6,3 mm	N° 9	N° 9	25	10605099	147,674
8 x 1,25	8,3 mm	11	11	25		
10 x 1,5	10,4 mm	13	13	25		



## 10600

### Kit per il ripristino delle filettature danneggiate





Thread repair kit / Trousse pour rétablir taraudages endommagés

Juego para reparar rosca dañada - Gewinde-reparatur-Sätze







Metal



#### BSW

				 1,5 d	cod.	€ cad/each
				pcs		
1/8 x 40	3,4 mm	N° 4	N° 4	20	10600168	55,041
3/16 x 24	5,0 mm	8	8	20	10600169	55,041
1/4 x 20	6,7 mm	9	9	20	10600170	49,566
5/16 x 18	8,3 mm	10	11	20	10600171	60,734
3/8 x 16	9,9 mm	12	12	15	10600172	64,791
7/16 x 14	11,5 mm	14	14	10	10600173	72,719
1/2 x 12	13,0 mm	15	15	10	10600174	79,830
9/16 x 12		16		10	10600175	107,195
5/8 x 11		18		10	10600176	107,195
3/4 x 10		20		5	10600177	136,216
7/8 x 9		22		5	10600178	166,035
1" x 8		23		4	10600179	157,982

#### BSF

				 1,5 d	cod.	€ cad/each
				pcs		
3/16 x 32	5,0 mm	N° 7	N° 6	20	10600185	55,041
1/4 x 26	6,6 mm	9	9	20	10600180	49,566
5/16 x 22	8,3 mm	11	11	20	10600181	60,734
3/8 x 20	9,9 mm	13	13	15	10600182	64,791
7/16 x 18	11,5 mm	14	14	10	10600183	72,719
1/2 x 16	13,0 mm	15	15	10	10600184	79,830
9/16 x 16		16		10	10600186	107,195
5/8 x 14		18		10	10600187	107,195
3/4 x 12		20		5	10600188	136,216
7/8 x 11		22		5	10600189	166,035
1" x 10		23		4	10600190	157,982

#### BSP

		 1,5 d	cod.	€ cad/each
	pcs	pcs		
G 1/8 x 28	1	10	10600191	111,946
1/4 x 19	1	10	10600192	121,799
3/8 x 19	1	10	10600193	130,752
1/2 x 14	1	10	10600194	158,521
5/8 x 14	1	10	10600195	372,559
3/4 x 14	1	10	10600196	372,559
7/8 x 14	1	10	10600197	512,263
1" x 11	1	10	10600198	512,263

# 10605

## Kit per il ripristino delle filettature danneggiate

Thread repair kit / Trousse pour rétablir taraudages endommagés





Juego para reparar rosca dañada - Gewinde-reparatur-Sätze



Metal





BSW

### Assortimenti - Sets

				 1,5 d pcs	cod.	€ cad/each
<b>BSW 1/4-1/2</b>						
1/4 x 20	6,7 mm	N° 9	N° 9	25	10605105	301,444
5/16 x 18	8,3 mm	10	11	25		
3/8 x 16	9,9 mm	12	12	25		
7/16 x 14	11,5 mm	14	14	10		
1/2 x 12	13,0 mm	15	15	10		

BSF

### Assortimenti - Sets

				 1,5 d pcs	cod.	€ cad/each
<b>BSF 1/4-1/2</b>						
1/4 x 20	6,6 mm	N° 9	N° 9	25	10605106	301,444
5/16 x 18	8,3 mm	11	11	25		
3/8 x 16	9,9 mm	12	12	25		
7/16 x 14	11,5 mm	14	14	10		
1/2 x 12	13,0 mm	15	15	10		

## 10600

### Kit per il ripristino delle filettature danneggiate



Thread repair kit / Trousse pour rétablir taraudages endommagés

Juego para reparar rosca dañada - Gewinde-reparatur-Sätze





Metal

### UNC

					cod.	€
				pcs		cad/each
<b>N° 6</b> x 32	3,8 mm	N°5	N°5	20	106001481	<b>61,158</b>
<b>8</b> x 32	4,4 mm	6	6	20	10600149	<b>61,158</b>
<b>10</b> x 24	5,2 mm	7	6	20	106001490	<b>61,158</b>
<b>12</b> x 24	5,8 mm	8	8	20	106001491	<b>61,158</b>
<b>UNC 1/4</b> x 20	6,7 mm	9	9	20	10600150	<b>55,072</b>
<b>5/16x</b> 18	8,3 mm	10	10	20	10600151	<b>67,482</b>
<b>3/8</b> x 16	9,9 mm	12	12	15	10600152	<b>71,995</b>
<b>7/16x</b> 14	11,6 mm	14	14	10	10600153	<b>80,802</b>
<b>1/2</b> x 13	13,0 mm	15	15	10	10600154	<b>88,700</b>
<b>9/16x</b> 12		16		10	10600155	<b>119,108</b>
<b>5/8</b> x 11		18		10	10600156	<b>119,108</b>
<b>3/4</b> x 10		20		5	10600157	<b>151,348</b>
<b>7/8</b> x 9		22		5	10600158	<b>184,489</b>
<b>1"</b> x 8		23		4	10600159	<b>175,536</b>
					cod.	€
				pcs		cad/each
<b>UNC 1.1/8</b> x 7		1		10	106001590	<b>496,800</b>
<b>1.1/4</b> x 7		1		10	106001591	<b>547,722</b>
<b>1.1/2</b> x 6		1		10	106001592	<b>733,950</b>

### UNF

					cod.	€
				pcs		cad/each
<b>N° 6</b> x 40	3,8 mm	N°5	N°5	20	106001597	<b>61,158</b>
<b>8</b> x 36	4,4 mm	6	6	20	106001598	<b>61,158</b>
<b>10</b> x 32	5,1 mm	8	8	20	106001599	<b>61,158</b>
<b>UNF 1/4</b> x 28	6,7 mm	9	9	20	10600160	<b>55,072</b>
<b>5/16x</b> 24	8,3 mm	11	11	20	10600161	<b>67,482</b>
<b>3/8</b> x 24	9,8 mm	13	13	15	10600162	<b>71,995</b>
<b>7/16x</b> 20	11,5 mm	14	14	10	10600163	<b>80,802</b>
<b>1/2</b> x 20	13,0 mm	15	15	10	10600164	<b>88,700</b>
<b>9/16x</b> 18		16		10	10600165	<b>119,108</b>
<b>5/8</b> x 18		18		10	10600166	<b>119,108</b>
<b>3/4</b> x 16		21		5	10600167	<b>151,348</b>
<b>7/8</b> x 14		22		5	106001670	<b>184,489</b>
<b>1"</b> x 12		23		4	106001671	<b>175,536</b>
					cod.	€
				pcs		cad/each
<b>UNF 1.1/8</b> x 12		1		10	106001672	<b>496,603</b>
<b>1.1/4</b> x 12		1		10	106001673	<b>547,722</b>
<b>1.1/2</b> x 12		1		10	106001674	<b>733,950</b>

# 10605

## Kit per il ripristino delle filettature danneggiate

Thread repair kit / Trousse pour rétablir taraudages endommagés





Juego para reparar rosca dañada - Gewinde-reparatur-Sätze



Metal





UNC

### Assortimenti - Sets

					 1,5 d pcs	cod.	€ cad/each
<b>UNC 1/4-1/2</b>							
1/4 x 20	6,7 mm	N° 9	N° 9	25	10605103	301,444	
5/16 x 18	8,3 mm	10	11	25			
3/8 x 16	9,9 mm	12	12	25			
7/16 x 14	11,5 mm	14	14	10			
1/2 x 12	13,0 mm	15	15	10			

UNF

### Assortimenti - Sets

					 1,5 d pcs	cod.	€ cad/each
<b>UNF 1/4-1/2</b>							
1/4 x 20	6,7 mm	N° 9	N° 9	25	10605104	301,444	
5/16 x 18	8,3 mm	11	11	25			
3/8 x 16	9,8 mm	13	13	25			
7/16 x 14	11,5 mm	14	14	10			
1/2 x 12	13,0 mm	15	15	10			

## 10631

### Kit per il ripristino delle filettature danneggiate, speciale per candele

Thread repair kit, special for spark plugs / Trousse pour rétablir les taraudages endommagés, spécial pour bougies

Juego para reparar roscas dañadas, especial para las roscas de las bujías / Gewindereparatur-Satz für Kerzen



Metal

M

STI		8,40 pcs	12,40 pcs	16,40 pcs	cod.	€ cad/each
M 14 x 1,25	N° 17	5	5	5	10631100	79,933

#### Ricambi - Spare parts

Filetto Thread	L	pcs	cod.	€ cad/each
14 x 1,25	8,4	50	1060614x12508	1,221
14 x 1,25	12,4	50	1060614x12512	1,221
14 x 1,25	16,4	50	1060614x12516	1,221

M

STI		1,5d pcs	cod.	€ cad/each
M12 x 1,25	N° 15	10	10631115	105,073
10 x 1,5	N° 13	10	10631114	79,933
10 x 1,25	N° 13	10	10631113	79,933
10 x 1	N° 13	10	10631112	79,933
8 x 1,25	N° 11	10	10631111	78,246
6 x 1	N° 9	10	10631110	64,884

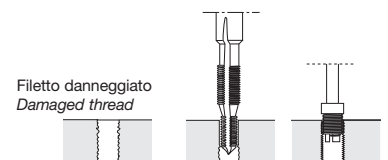

# 10631

## Kit per il ripristino delle filettature danneggiate con inserto solido

Thread repair kit with solid thread insert / Trousse pour rétablir les taraudages endommagés,  
Juego para reparar roscas dañadas / Gewindereparatur-Satz



**Speciale per candele M14x1,25 - Special for spark plugs M14X1,25**



M

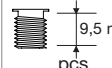
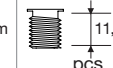
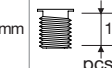

Metal

	 9,5 mm pcs	 11,2 mm pcs	 12,7 mm pcs	 17,5 mm pcs	cod.	€ cad/each
M 16 x 1,25	4	4	4	4	10631130	92,964

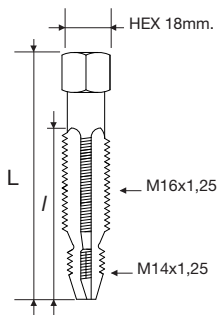
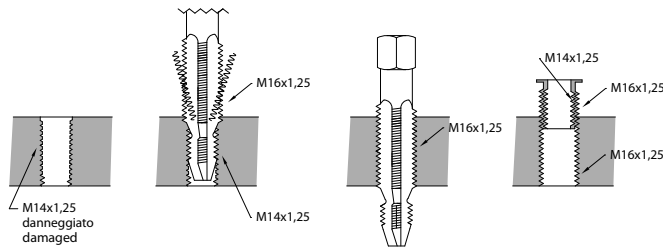

### Ricambi - Spare parts

#### Maschio combinato - Combined tap

	L	l	pcs	cod.	€ cad/each
M 16 x 1,25	70	41	1	1062616x125	70,535

#### Inserto solido - Solid insert

Ø	 mm	pcs	cod.	€ cad/each
M 14 x 1,25	9,5	50	1062714x12509	3,395
14 x 1,25	11,2	50	1062714x12511	3,509
14 x 1,25	12,7	50	1062714x12512	3,509
14 x 1,25	17,5	50	1062714x12517	3,726

**Speciale per candelette 8-10-12 mm - Special for glow plugs 8-10-12 mm**

M

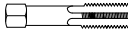
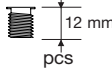

Abs

	 12 mm pcs	cod.	€ cad/each
M 8x1 - M 10x1 - M 10x1,25 M 12x1 - M 12x1,25 - M 14x1,25	M 8x1 - M 10x1 - M 10x1,25 M 12x1	10631205	289,800

il set contiene un'asta di montaggio, con relativa impugnatura, 3 tappi e 2 utensili inseritori.  
This set contains 1 insert fitting rod, its grip handle, 3 plug end blanks and 2 insert fitting tools.

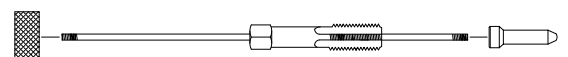

### Inserti filettati in acciaio inox per il ripristino delle filettature danneggiate

Wire-thread insert in stainless steel / Ressorts filetéés en acier inoxydable pour le retablisement des filets endommagés

Inserto roscado para sustituir rosca danada / Gewinde Einsätze aus rostfreiem Stahl



**INOX**  
18/8

**DIN**  
8140

**ISO2**  
6H

**M**

Filetto Thread	pcs	1xd		1,5xd		2xd		2,5xd		3xd	
		cod.	€ cad/each	cod.	€ cad/each	cod.	€ cad/each	cod.	€ cad/each	cod.	€ cad/each
M 2 x 0,4	100	10606102x04	1,025	1060602x04	1,221	10606202x04	1,553	106062502X04	1,656	10606302x04	2,194
2,2 x 0,45	100	106061022x045	1,025	10606022x045	1,221	106062022x045	1,553	1060625022X04	1,656	106063022x045	2,194
2,5 x 0,45	100	106061025x045	0,300	10606025x045	0,414	106062025x045	0,621	1060625025X04	0,725	106063025x045	0,932
3 x 0,5	100	10606103x05	0,300	1060603x05	0,331	10606203x05	0,393	106062503X05	0,580	10606303x05	0,600
3,5 x 0,6	100	106061035x06	0,352	10606035x06	0,331	106062035x06	0,393	1060625035X06	0,725	106063035x06	0,828
4 x 0,7	100	10606104x07	0,300	1060604x07	0,300	10606204x07	0,352	106062504X07	0,528	10606304x07	0,631
5 x 0,8	100	10606105x08	0,311	1060605x08	0,248	10606205x08	0,393	106062505X08	0,455	10606305x08	0,538
6 x 1	100	10606106x1	0,311	1060606x1	0,259	10606206x1	0,455	106062506X1	0,466	10606306x1	0,590
7 x 1	100	10606107x1	0,331	1060607x1	0,445	10606207x1	0,549	106062507X1	0,673	10606307x1	0,963
8 x 1,25	100	10606108x125	0,362	1060608x125	0,331	10606208x125	0,590	106062508X125	0,631	10606308x125	0,880
8 x 1	100	10606108x1	0,362	1060608x1	0,331	10606208x1	0,549	106062508X1	0,631	10606308x1	0,745
9 x 1,25	100	10606109x125	0,518	1060609x125	0,600	10606209x125	0,745	106062509X125	1,190	10606309x125	1,418
10 x 1,5	100	10606110x15	0,476	1060610x15	0,497	10606210x15	0,631	106062510X15	0,745	10606310x15	0,963
10 x 1,25	100	10606110x125	0,476	1060610x125	0,497	10606210x125	0,631	106062510X125	0,745	10606310x125	0,963
10 x 1	100	10606110x1	0,476	1060610x1	0,497	10606210x1	0,631	106062510X1	0,745	10606310x1	0,963
11 x 1,5	100	10606111x15	0,787	1060611x15	0,838	10606211x15	1,004	106062511X15	1,511	10606311x15	1,708
12 x 1,75	100	10606112x175	0,673	1060612x175	0,683	10606212x175	0,859	106062512X175	0,911	10606312x175	1,366
12 x 1,5	100	10606112x15	0,673	1060612x15	0,683	10606212x15	0,859	106062512X15	0,911	10606312x15	1,366
12 x 1,25	100	10606112x125	0,673	1060612x125	0,683	10606212x125	0,859	106062512X125	0,911	10606312x125	1,366
12 x 1	100	10606112x1	0,673	1060612x1	0,683	10606212x1	0,859	106062512X1	0,911	10606312x1	1,366
14 x 2	50	10606114x2	0,994	1060614x2	0,859	10606214x2	1,118	106062514X2	1,242	10606314x2	1,977
14 x 1,5	50	10606114x15	0,994	1060614x15	0,859	10606214x15	1,118	106062514X15	1,242	10606314x15	1,811
14 x 1,25	50	10606114x125	0,994	1060614x125	0,859	10606214x125	1,118	106062514X125	1,242	10606314x125	1,811
14 x 1	50	10606114x1	0,994	1060614x1	0,859	10606214x1	1,118	106062514X1	1,242	10606314x1	1,811
16 x 2	50	10606116x2	1,139	1060616x2	0,973	10606216x2	1,470	106062516X2	1,811	10606316x2	2,174
16 x 1,5	50	10606116x15	1,139	1060616x15	0,973	10606216x15	1,470	106062516X15	1,811	10606316x15	2,174
18 x 2,5	25	10606118x25	1,656	1060618x25	1,553	10606218x25	2,619	106062518X25	2,898	10606318x25	3,509
18 x 2	25	10606118x2	1,656	1060618x2	1,553	10606218x2	2,619	106062518X2	2,898	10606318x2	3,509
18 x 1,5	25	10606118x15	1,656	1060618x15	1,553	10606218x15	2,619	106062518X15	2,898	10606318x15	3,509
20 x 2,5	25	10606120x25	2,174	1060620x25	1,967	10606220x25	3,333	106062520X25	3,985	10606320x25	4,461
20 x 2	25	10606120x2	2,174	1060620x2	1,967	10606220x2	3,333	106062520X2	3,985	10606320x2	4,461
20 x 1,5	25	10606120x15	2,174	1060620x15	1,967	10606220x15	3,333	106062520X15	3,985	10606320x15	4,461
22 x 2,5	10	10606122x25	2,484	1060622x25	2,588	10606222x25	3,736	106062522X25	4,482	10606322x25	4,782
22 x 2	10	10606122x2	2,484	1060622x2	2,588	10606222x2	3,736	106062522X2	4,482	10606322x2	4,782
22 x 1,5	10	10606122x15	2,484	1060622x15	2,588	10606222x15	3,736	106062522X15	4,482	10606322x15	4,782
24 x 3	10	10606124x3	2,898	1060624x3	2,898	10606224x3	4,357	106062524X3	5,227	10606324x3	5,382
24 x 2	10	10606124x2	2,898	1060624x2	2,898	10606224x2	4,357	106062524X2	5,227	10606324x2	5,382
24 x 1,5	10	10606124x15	2,898	1060624x15	2,898	10606224x15	4,357	106062524X15	5,227	10606324x15	5,382
26 x 1,5	5	-	-	1060626x15	4,813	-	-	-	-	-	-
27 x 3	5	-	-	1060627x3	4,813	-	-	-	-	-	-
27 x 2	5	-	-	1060627x2	4,813	-	-	-	-	-	-
27 x 1,5	5	-	-	1060627x15	4,813	-	-	-	-	-	-
28 x 1,5	5	-	-	1060628x15	5,434	-	-	-	-	-	-
30 x 3,5	5	-	-	1060630x35	6,334	-	-	-	-	-	-
30 x 2	5	-	-	1060630x2	6,334	-	-	-	-	-	-
30 x 1,5	5	-	-	1060630x15	6,334	-	-	-	-	-	-
33 x 3,5	5	-	-	1060633x35	7,576	-	-	-	-	-	-
33 x 2	5	-	-	1060633x2	7,576	-	-	-	-	-	-
36 x 4	5	-	-	1060636x4	6,955	-	-	-	-	-	-
36 x 3	5	-	-	1060636x3	6,955	-	-	-	-	-	-
36 x 2	5	-	-	1060636x2	6,955	-	-	-	-	-	-
36 x 1,5	5	-	-	1060636x15	6,955	-	-	-	-	-	-

## Inserti filettati autobloccanti in acciaio inox per il ripristino delle filettature danneggiate

Stainless steel wire thread inserts, screw self-locking to renew damaged threads / Ressorts filetés en acier inoxydable autobloquants pour le retenir filets endommagés / Inserto roscado, autobloccante in acero inoxidable para sustituir rosca dañada / Selbstsperrend Gewinde Einsätze aus rostfreiem Stahl



**INOX**  
18/8

**DIN**  
8140

**ISO2**  
6H

**M**

Filetto Thread	pcs	1xd		1,5xd		2xd	
		cod.	€ cad/each	cod.	€ cad/each	cod.	€ cad/each
M 3 x 0,5	100	10625103x05	0,445	1062503x05	0,466	10625203x05	0,497
4 x 0,7	100	10625104x07	0,445	1062504x07	0,466	10625204x07	0,497
5 x 0,8	100	10625105x08	0,497	1062505x08	0,518	10625205x08	0,569
6 x 1	100	10625106x1	0,549	1062506x1	0,600	10625206x1	0,652
8 x 1,25	100	10625108x125	0,569	1062508x125	0,652	10625208x125	0,787
10 x 1,5	100	10625110x15	0,735	1062510x15	0,787	10625210x15	0,911
12 x 1,75	100	10625112x175	1,066	1062512x175	1,221	10625212x175	1,387
14 x 2	50	10625114x2	1,511	1062514x2	1,718	10625214x2	1,801
16 x 2	50	10625116x2	2,039	1062516x2	2,142	10625216x2	2,639

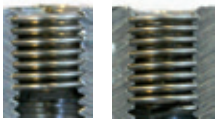

1xd 1,5xd

**Nota:** la misura è riferita all'inserto posizionato nella sua sede  
**Note:** the coil length refers to the tool mounted inside its site

### Consigli d'uso / Use tips

Si consiglia l'utilizzo di inserti autobloccanti nel caso di sollecitazioni cicliche del filetto o della necessità di una particolare resistenza agli impatti. Si consiglia inoltre l'uso con viti nichelate o ben lubrificate. L'inserto autobloccante è dotato di alcune spire poligonali inserite tra le spire circolari per tutta la sua lunghezza: tali spire poligonali esercitano una pressione radiale maggiore sulla vite inserita nell'inserto funzionando da bloccaggio. Rimuovendo la vite, le spire poligonali tornano nella loro forma originale garantendo un ottimo livello di pressione radiale per una serie di avvitature/svitature successive.

Screw locking inserts are of particular value in applications subject to the effects of cyclic vibration or impact. The prevailing locking torque they assure is achieved by the action of one or more polygonal grip coils positioned within the insert's length, which exert radial pressure on the male thread. As the male thread passes through these grip coils, the locking flats are displaced thus exerting radial pressure or prevailing torque on the male thread. When removing the male thread, the locking coils relax to their original form permitting repeated assembly while retaining a measurable level of prevailing torque. Please use only close fit plated or lubricated bolts or screws with the screw locking inserts.

Les filets rapportés à frein de vis sont extrêmement utiles pour les applications sujettes aux effets provoqués par les vibrations cycliques ou les chocs. Ils offrent une sécurité supplémentaire avec le couple de freinage permanent. Ceci est accompli par la pression radiale exercée sur le filetage extérieur par une ou plusieurs spires à déformation polygonale positionnées sur la longueur du filet rapporté. Tandis que le filetage extérieur passe à travers ces spires déformées, les vis à tête plate sont déplacées, exerçant ainsi une pression radiale ou couple permanent sur le filetage extérieur. Lorsque le filetage extérieur est retiré, les spires de freinage débandent pour atteindre leur forme originale, permettant des assemblages répétés tout en conservant un niveau mesurable de couple permanent. Il est recommandé que seuls des boulons ou vis lubrifiés ou à tête plate à ajustement serré soient utilisés avec les filets rapportés à frein de vis.

El inserto autobloccante está especialmente indicado en aplicaciones sujetas a vibración cíclica o impactos. Los insertos autobloccantes ofrecen una seguridad adicional por su auto freno interno que lo hace más efectivo. Esto se consigue gracias a la acción de uno a varios hilos poligonales de la rosca del inserto posicionados a lo largo mismo, que ejercen presión radial o freno efectivo en la rosca del tornillo. En la medida en que la rosca pasa a través de estos hilos de seguridad, los dispositivos se expanden aplicando gradualmente presión radial o freno efectivo en la rosca del tornillo. Al retirar el tornillo roscado, los hilos de seguridad relajan su expansión a su forma original permitiendo repetir el roscado del tornillo y manteniendo su nivel de presión radial de seguridad. Se recomienda que solamente se utilicen tornillos niquelados o bien lubricados, con los insertos de seguridad.



## Inserti filettati in acciaio inox per il ripristino delle filettature danneggiate

Wire-thread insert in stainless steel / Ressorts filetées en acier inoxydable pour le retablissement des filets endommagés



Inserto roscado para sustituir rosca dañada / Gewinde Einsätze aus rostfreiem Stahl





INOX 18/8  
DIN 8140  
ISO2 6H  
UNC

INOX 18/8  
DIN 8140  
ISO2 6H  
UNF

### 10607

Filetto Thread	pcs 	cod.  1,5 d	€ cad/each
N° 8 x 32	100	10607N08	0,476
10 x 24	100	10607N10	0,476
12 x 24	100	10607N12	0,476
UNC 1/4 x 20	100	106071/4	0,683
5/16 x 18	100	106075/16	0,683
3/8 x 16	100	106073/8	0,880
7/16 x 14	100	106077/16	1,170
1/2 x 13	100	106071/2	1,170
9/16 x 12	50	106079/16	4,109
5/8 x 11	50	106075/8	4,109
3/4 x 10	25	106073/4	4,854
7/8 x 9	10	106077/8	7,110
1" x 8	10	106071"	7,110
1.1/8 x 7	5	106071.1/8	11,509
1.1/4 x 7	5	106071.1/4	12,637
1.1/2 x 6	5	106071.1/2	16,250

### 10608

Filetto Thread	pcs 	cod.  1,5 d	€ cad/each
N° 8 x 36	100	10608N08	1,087
10 x 32	100	10608N10	0,683
UNF 1/4 x 28	100	106081/4	0,683
5/16 x 24	100	106085/16	0,683
3/8 x 24	100	106083/8	0,880
7/16 x 20	100	106087/16	1,170
1/2 x 20	100	106081/2	1,170
9/16 x 18	50	106089/16	4,109
5/8 x 18	50	106085/8	4,109
3/4 x 16	25	106083/4	4,854
7/8 x 14	10	106087/8	7,110
1" x 12	10	106081"	7,110
1.1/8 x 12	5	106081.1/8	11,509
1.1/4 x 12	5	106081.1/4	12,637
1.1/2 x 12	5	106081.1/2	16,250

## Inserti filettati in acciaio inox per il ripristino delle filettature danneggiate

Wire-thread insert in stainless steel / Ressorts filetées en acier inoxydable pour le retablisement des filets endommagés



Inserto roscado para sustituir rosca dañada / Gewinde Einsätze aus rostfreiem Stahl





INOX 18/8	DIN 8140	ISO2 6H	BSW
--------------	-------------	------------	-----

INOX 18/8	DIN 8140	ISO2 6H	BSF
--------------	-------------	------------	-----

### 10609



Filetto Thread	pcs 	cod. 	€ cad/each
1/8 x 40	100	106091/8	1,439
3/16 x 24	100	106093/16	1,439
1/4 x 20	100	106091/4	0,590
5/16 x 18	100	106095/16	0,725
3/8 x 16	100	106093/8	1,201
7/16 x 14	100	106097/16	1,490
1/2 x 12	100	106091/2	1,490
9/16 x 12	50	106099/16	4,264
5/8 x 11	50	106095/8	4,264
3/4 x 10	25	106093/4	5,082
7/8 x 9	10	106097/8	7,110
1" x 8	10	106091"	8,125

### 10610

Filetto Thread	pcs 	cod. 	€ cad/each
3/16 x 32	100	106103/16	1,439
1/4 x 26	100	106101/4	1,439
5/16 x 22	100	106105/16	1,439
3/8 x 20	100	106103/8	1,439
7/16 x 18	100	106107/16	1,490
1/2 x 16	100	106101/2	1,490
9/16 x 16	50	106109/16	4,264
5/8 x 14	50	106105/8	4,264
3/4 x 12	25	106103/4	5,082
7/8 x 11	10	106107/8	7,110
1" x 10	10	106101"	8,125

INOX 18/8	DIN 8140	ISO2 6H	BSP
--------------	-------------	------------	-----

### 10604

Filetto Thread	pcs 	cod. 	€ cad/each
G 1/8 x 28	50	106041/8	1,066
1/4 x 19	50	106041/4	1,594
3/8 x 19	50	106043/8	1,873
1/2 x 14	50	106041/2	2,401
5/8 x 14	5	106045/8	5,993
3/4 x 14	5	106043/4	5,993
7/8 x 14	5	106047/8	18,392
1" x 11	5	106041"	18,392

## 10612

### Maschi STI per l'inserimento di inserti filettati

STI taps for wire thread inserts / Tarauds STI pour l'insertion des ressorts filetés

Machos STI para la inserción de filetes / Gewindebohrer STI für gewinde Einsätze

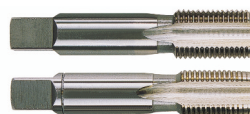

Filetto Thread	cod.	€ cad/each
M 2 x 0,4	1061202X04	14,894
2,5 x 0,45	10612025X045	14,894
3 x 0,5	1061203X05	11,447
3,5 x 0,6	10612035X06	11,447
4 x 0,7	1061204X07	11,447
5 x 0,8	1061205X08	11,447
6 x 1	1061206X1	11,447
7 x 1	1061207X1	14,159
8 x 1,25	1061208X125	14,159
8 x 1	1061208X1	14,159
9 x 1,25	1061209X125	17,450
10 x 1,5	1061210X15	17,450
10 x 1,25	1061210X125	17,450
10 x 1	1061210X1	17,450
11 x 1,5	1061211X15	19,603
12 x 1,75	1061212X175	23,971
12 x 1,5	1061212X15	23,971
12 x 1,25	1061212X125	23,971
12 x 1	1061212X1	23,971
14 x 2	1061214X2	27,231
14 x 1,5	1061214X15	27,231
14 x 1,25	1061214X125	27,231
14 x 1	1061214X1	27,231
16 x 2	1061216X2	32,675
16 x 1,5	1061216X15	32,675
18 x 2,5	1061218X25	40,400
18 x 2	1061218X2	40,400
18 x 1,5	1061218X15	40,400
20 x 2,5	1061220X25	45,768
20 x 2	1061220X2	45,768
20 x 1,5	1061220X15	45,768
22 x 2,5	1061222X25	52,309
22 x 2	1061222X2	52,309
22 x 1,5	1061222X15	52,309
24 x 3	1061224X3	66,457
24 x 2	1061224X2	66,457
24 x 1,5	1061224X15	66,457

Filetto Thread	cod.	€ cad/each
M 26 x 1,5	1061226X15	263,294
27 x 3	1061227X3	263,294
27 x 2	1061227X2	263,294
27 x 1,5	1061227X15	263,294
28 x 1,5	1061228X15	297,324
30 x 3,5	1061230X35	297,324
30 x 2	1061230X2	297,324
30 x 1,5	1061230X15	297,324
33 x 3,5	1061233X35	297,324
33 x 2	1061233X2	297,324
36 x 4	1061236X4	329,565
36 x 3	1061236X3	329,565
36 x 2	1061236X2	329,565
36 x 1,5	1061236X15	329,565

# 10620

## Maschio combi per l'inserimento di inserti filettati - speciale per candele

Spark plug taps with pilot nose for wire thread insert / Tarauds indique pour bugies

Machos indicado para bujias / Kombi-gewindebohrer für gewinde Einsätze

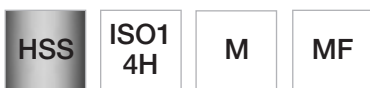

Filetto Thread		cod.	€ cad/each
<b>M 6</b>	x 1	1062006X1	<b>22,760</b>
<b>8</b>	x 1,25	1062008X125	<b>22,760</b>
<b>10</b>	x 1,5	1062010X15	<b>28,752</b>
<b>10</b>	x 1,25	1062010X125	<b>39,330</b>
<b>10</b>	x 1	1062010X1	<b>39,330</b>
<b>12</b>	x 1,25	1062012X125	<b>41,379</b>
<b>14</b>	x 1,25	1062014X125	<b>47,993</b>
<b>18</b>	x 1,5	1062018X15	<b>68,683</b>

## Maschi STI per l'inserimento di inserti filettati

STI taps for wire thread inserts / Tarauds STI pour l'insertion des ressorts filetés

Machos STI para la inserción de filetes / Gewindebohrer STI für gewinde Einsätze

**HSS** **FORM D** **UNC**

### 10613



	Filetto Thread	cod.	€ cad/each
N°	8 x 32	10613NR08	19,862
	10 x 24	10613NR10	19,862
	12 x 24	10613NR12	19,862
UNC	1/4 x 20	106131/4	13,093
	5/16 x 18	106135/16	14,221
	3/8 x 16	106133/8	14,894
	7/16 x 14	106137/16	19,862
	1/2 x 13	106131/2	22,573
	9/16 x 12	106139/16	37,457
	5/8 x 11	106135/8	46,265
	3/4 x 10	106133/4	56,201
	7/8 x 9	106137/8	65,443
1" x 8	106131"	85,605	



	Filetto Thread	cod.	€ cad/each
UNC	1.1/8 x 7	106131.1/8	223,891
	1.1/4 x 7	106131.1/4	268,665
	1.1/2 x 6	106131.1/2	436,139

**HSS** **FORM D** **UNF**

### 10614



	Filetto Thread	cod.	€ cad/each
N°	8 x 36	10614NR08	19,862
	10 x 32	10614NR10	19,862
UNF	1/4 x 28	106141/4	13,093
	5/16 x 24	106145/16	14,221
	3/8 x 24	106143/8	14,894
	7/16 x 20	106147/16	19,862
	1/2 x 20	106141/2	23,474
	9/16 x 18	106149/16	37,457
	5/8 x 18	106145/8	46,265
	3/4 x 16	106143/4	56,201
	7/8 x 14	106147/8	65,443
	1" x 12	106141"12	82,086
1" x 14	106141"14	82,086	



	Filetto Thread	cod.	€ cad/each
UNF	1.1/8 x 12	106141.1/8	223,891
	1.1/4 x 12	106141.1/4	268,665
	1.1/2 x 12	106141.1/2	436,139

## Maschi STI per l'inserimento di inserti filettati

STI taps for wire thread inserts / Tarauds STI pour l'insertion des ressorts filetés

Machos STI para la inserción de filetes / Gewindebohrer STI für gewinde Einsätze



# 10615



Filetto Thread	cod.	€ cad/each
<b>BSW</b> 1/8 x 40	106151/8	13,093
3/16 x 24	106153/16	13,093
1/4 x 20	106151/4	13,093
5/16 x 18	106155/16	14,221
3/8 x 16	106153/8	14,894
7/16 x 14	106157/16	19,862
1/2 x 12	106151/2	22,573
9/16 x 12	106159/16	37,457
5/8 x 11	106155/8	46,265
3/4 x 10	106153/4	56,201
7/8 x 9	106157/8	65,443
1" x 8	106151"	85,605



# 10616



Filetto Thread	cod.	€ cad/each
<b>BSF</b> 3/16 x 32	106163/16	13,724
1/4 x 26	106161/4	13,093
5/16 x 22	106165/16	14,221
3/8 x 20	106163/8	14,894
7/16 x 18	106167/16	19,862
1/2 x 16	106161/2	22,573
9/16 x 16	106169/16	39,268
5/8 x 14	106165/8	48,479
3/4 x 12	106163/4	58,902
7/8 x 11	106167/8	68,579
1" x 10	106161"	85,605



# 10617



Filetto Thread	cod.	€ cad/each
<b>BSP</b> 1/8 x 28	106171/8	43,460
1/4 x 19	106171/4	57,960
3/8 x 19	106173/8	72,305
1/2 x 14	106171/2	83,970
5/8 x 14	106175/8	115,920
3/4 x 14	106173/4	173,880
7/8 x 14	106177/8	219,089
1" x 11	106171"	270,456

## Accessori per l'utilizzo degli inserti filettati

Inserting tools for wire thread inserts / Outils pour l'utilisation des ressort filetés

Herramientas para insertar filetes / Werkzeuge für Gewinde Einsätze

HSS

DIN  
338

## 01060



### Punta elicoidale per prefili fil. danneggiate

Twist drill for damaged threads

Foret hélicoïdal pour taraudages endommagés

Broca helicoidal para roscas dañadas.

d <sub>1</sub>	l <sub>1</sub>	l <sub>2</sub>	Per filetto for thread	cod.	€ cad/each
2,1	24	49	M2 x 0,4	010600210	0,973
2,6	30	57	2,5 x 0,45	010600260	1,118
3,2	36	65	3 x 0,5	010600320	1,201
3,7	39	70	3,5 x 0,6	010600370	1,314
4,2	43	75	4 x 0,7	010600420	1,625
5,2	52	86	5 x 0,8	010600520	2,132
6,3	63	101	6 x 1	010600630	2,960
7,3	69	109	7 x 1	010600730	3,788
8,3	75	117	8 x 1,25- 8 x 1	010600830	5,227
9,3	81	125	9 x 1,25	010600930	6,138
10,3	87	133	10 x 1,25-10 x 1	010601030	8,311
10,4	87	133	10 x 1,5	010601040	8,311
11,4	94	133	11 x 1,5	010601140	10,578
12,3	101	133	12 x 1,25-12 x 1	010601230	12,575
12,4	101	133	12 x 1,75-12 x 1,5	010601240	12,575

d<sub>1</sub>>12,4 mm su richiesta / On demand

## 10611



### Utensile per la rottura del perno di trascinamento K-coil

Tang break tool / Outil pour rompre le goujon

Herramienta rompe arrastre

Per coil for coil	N°	cod.	€ cad/each
M 2	2	1061102	3,519
2,5	3	1061103	3,519
3	4	1061104	3,519
3,5	5	1061105	3,519
4	6	1061106	3,519
5	8	1061108	3,519
6	9	1061109	3,519
7+8	11	1061111	3,954
9	12	1061112	3,954
10	13	1061113	3,954
11	14	1061114	4,771
12	15	1061115	4,771

## 10622



### Estrattore K-coil

Extracting tool / Outil pour enlever le K-coil

Herramienta extractora

N°	Per coil for coil	cod.	€ cad/each
2	M 3÷10 3/16÷3/8	1062202	32,499
3	M 11÷24 3/8÷1"	1062203	39,537

## Accessori per l'utilizzo degli inserti filettati

Inserting tools for wire thread inserts / Outils pour l'utilisation des ressort filetés

Herramientas para insertar filetes / Werkzeuge für Gewinde Einsätze

### 10621



#### Utensile manuale per inserire i K-coil

Inserting tool for K-coil / Outil pour l'insertion des K-coil

Utensilio para insertar K-coil

Per coil for coil	N°	cod.	€ cad/each
M 2	2	1062102	10,774
2,5	3	1062103	10,774
3	4	1062104	10,288
3,5	5	1062105	10,288
4	6	1062106	10,288
5	8	1062108	11,571
6	9	1062109	11,571
7	10	1062110	13,207
8	11	1062111	13,207
9	12	1062112	14,221
10	13	1062113	14,221
11	14	1062114	16,653
12	15	1062115	16,653
14x2-14x1,5	16	1062116	19,903
14x1,25-14x1	17	1062117	19,903
16	18	1062118	24,374
18	20	1062120	24,374
20	21	1062121	24,374
22	22	1062122	30,688
24	23	1062123	30,688

### 10623



#### Inseritore con attacco esagonale da 1/2"

Inserting tool with 1/2" hexagonal drive / Outil pour l'insertion avec attelage

hexagonal 1/2" / Herramienta para insertar con ataque hexagonal 1/2"

Per coil for coil	cod.	€ cad/each	Per coil for coil	cod.	€ cad/each
M 26 x 1,5	1062326X15	38,481	UNC 1.1/8 x 7	10623UNC1.1/8	46,171
27 x 3	1062327X3	38,481	1.1/4 x 7	10623UNC1.1/4	46,171
27 x 2	1062327X2	38,481	1.1/2 x 6	10623UNC1.1/2	53,623
27 x 1,5	1062327X15	38,481			
28 x 1,5	1062328X15	38,481	UNF 1.1/8 x 12	10623UNF1.1/8	46,171
30 x 3,5	1062330X35	46,171	1.1/4 x 12	10623UNF1.1/4	46,171
30 x 2	1062330X2	46,171	1.1/2 x 12	10623UNF1.1/2	53,623
30 x 1,5	1062330X15	46,171			
33 x 3,5	1062333X35	53,623	G * 1/8 x 28	10623G1/8	23,091
33 x 2	1062333X2	53,623	* 1/4 x 19	10623G1/4	23,091
36 x 4	1062336X4	53,623	* 3/8 x 19	10623G3/8	26,817
36 x 3	1062336X3	53,623	* 1/2 x 14	10623G1/2	30,781
36 x 2	1062336X2	53,623	5/8 x 14	10623G5/8	38,481
36 x 1,5	1062336X15	53,623	3/4 x 14	10623G3/4	38,481
			7/8 x 14	10623G7/8	53,623
			1" x 11	10623G1	53,623

\* Attacco da 1/4" / 1/4" hexagonal drive  
Queue 1/4" / Mango hexagonal 1/4"

### 10628



#### Inseritore con attacco 1/4" QC

Inserting tool with 1/4" QC hex shank / Outil pour l'insertion

avec attelage hex 1/4" QC / Herramienta para insertar con

ataque hex 1/4" QC

Per coil for coil	cod.	€ cad/each
M3	1062803X05	19,148
M4	1062804X07	19,148
M5	1062805X08	19,148
M6	1062806X1	19,148
M8	1062808X125	23,702
M10	1062810X15	26,082
M12	1062812X175	30,843



## > TABELLE

# TECHNICAL



I parametri di taglio consigliati nelle tabelle tecniche seguenti si riferiscono a utensili privi di rivestimento. Nel caso si utilizzino utensili rivestiti al TiN, si consiglia di aumentare i valori indicati del 20%, mantenendo una buona lubrorefrigerazione. Nel caso invece di utensili rivestiti al TiAlN, si consiglia di lavorare a secco, con parametri di taglio incrementati di 30-50%, prestando attenzione a non superare la temperatura T=850°C durante le lavorazioni; se necessario ridurre i parametri di taglio.

Technical tables  
Tableaux techniques  
Prospectos técnico  
Technische Tabellen

... della velocità periferica di taglio in n° giri  
... diametro della punta (diametro esterno per filetti, diametro interno per fori)  
... (conversion of velocities in rpm in function of diameter of the tool)

D		V (m/min)															
		6	8	10	12	15	18	20	25	30	35	40	45	50	60	70	80
10	100	100	120	140	160	180	200	220	250	280	300	320	350	380	400	450	
15	150	150	180	210	240	270	300	330	380	420	450	480	520	550	600	650	
20	200	200	240	280	320	360	400	450	500	550	600	650	700	750	800	900	
25	250	250	300	350	400	450	500	550	620	700	750	800	850	900	950	1050	
30	300	300	360	420	480	540	600	660	750	850	900	950	1000	1050	1100	1200	
35	350	350	420	480	540	600	660	720	820	950	1000	1050	1100	1150	1200	1300	
40	400	400	480	560	640	720	800	880	1000	1150	1200	1250	1300	1350	1400	1500	
45	450	450	540	630	720	810	900	990	1120	1300	1350	1400	1450	1500	1550	1650	
50	500	500	600	700	800	900	1000	1100	1250	1450	1500	1550	1600	1650	1700	1800	
55	550	550	660	770	880	990	1100	1210	1380	1600	1650	1700	1750	1800	1850	1950	
60	600	600	720	840	960	1080	1200	1320	1520	1750	1800	1850	1900	1950	2000	2100	
65	650	650	780	910	1040	1170	1300	1430	1650	1900	1950	2000	2050	2100	2150	2250	
70	700	700	840	990	1140	1290	1440	1590	1820	2100	2150	2200	2250	2300	2350	2450	
75	750	750	900	1060	1220	1380	1540	1700	1950	2250	2300	2350	2400	2450	2500	2600	
80	800	800	960	1130	1300	1470	1640	1810	2080	2400	2450	2500	2550	2600	2650	2750	
85	850	850	1020	1200	1380	1560	1740	1920	2200	2550	2600	2650	2700	2750	2800	2900	
90	900	900	1080	1270	1460	1650	1840	2030	2320	2700	2750	2800	2850	2900	2950	3050	
95	950	950	1140	1340	1540	1740	1940	2140	2450	2850	2900	2950	3000	3050	3100	3200	
100	1000	1000	1200	1410	1620	1830	2040	2250	2580	3000	3050	3100	3150	3200	3250	3350	
105	1050	1050	1260	1480	1700	1920	2140	2360	2700	3150	3200	3250	3300	3350	3400	3500	
110	1100	1100	1320	1560	1780	2010	2240	2470	2820	3300	3350	3400	3450	3500	3550	3650	
115	1150	1150	1380	1650	1880	2120	2360	2600	2960	3450	3500	3550	3600	3650	3700	3800	
120	1200	1200	1440	1740	2040	2280	2530	2780	3160	3650	3700	3750	3800	3850	3900	4000	
125	1250	1250	1500	1830	2160	2410	2660	2910	3300	3800	3850	3900	3950	4000	4050	4150	
130	1300	1300	1560	1920	2280	2540	2800	3050	3460	4000	4050	4100	4150	4200	4250	4350	
135	1350	1350	1620	2010	2400	2660	2920	3170	3580	4150	4200	4250	4300	4350	4400	4500	
140	1400	1400	1680	2100	2520	2780	3040	3290	3720	4300	4350	4400	4450	4500	4550	4650	
145	1450	1450	1740	2190	2640	2900	3160	3410	3860	4450	4500	4550	4600	4650	4700	4800	
150	1500	1500	1800	2280	2760	3020	3280	3530	3980	4600	4650	4700	4750	4800	4850	4950	
155	1550	1550	1860	2370	2880	3140	3400	3650	4100	4750	4800	4850	4900	4950	5000	5100	
160	1600	1600	1920	2460	3000	3260	3520	3770	4220	4900	4950	5000	5050	5100	5150	5250	
165	1650	1650	1980	2550	3120	3380	3640	3890	4340	5050	5100	5150	5200	5250	5300	5400	
170	1700	1700	2040	2640	3240	3500	3760	4010	4460	5200	5250	5300	5350	5400	5450	5550	
175	1750	1750	2100	2730	3360	3620	3880	4130	4580	5350	5400	5450	5500	5550	5600	5700	
180	1800	1800	2160	2820	3480	3740	4000	4250	4700	5500	5550	5600	5650	5700	5750	5850	
185	1850	1850	2220	2910	3600	3860	4120	4370	4820	5650	5700	5750	5800	5850	5900	6000	
190	1900	1900	2280	3000	3720	4080	4340	4590	4940	5800	5850	5900	5950	6000	6050	6150	
195	1950	1950	2340	3090	3840	4200	4460	4710	5060	5950	6000	6050	6100	6150	6200	6300	
200	2000	2000	2400	3180	3960	4320	4580	4830	5180	6100	6150	6200	6250	6300	6350	6450	
205	2050	2050	2460	3270	4080	4440	4700	4950	5300	6250	6300	6350	6400	6450	6500	6600	
210	2100	2100	2520	3360	4200	4560	4780	5030	5380	6400	6450	6500	6550	6600	6650	6750	
215	2150	2150	2580	3450	4320	4680	4900	5150	5500	6550	6600	6650	6700	6750	6800	6900	
220	2200	2200	2640	3540	4440	4800	5020	5270	5620	6700	6750	6800	6850	6900	6950	7050	
225	2250	2250	2700	3630	4560	4920	5140	5390	5740	6850	6900	6950	7000	7050	7100	7200	
230	2300	2300	2760	3720	4680	5040	5260	5510	5860	7000	7050	7100	7150	7200	7250	7350	
235	2350	2350	2820	3810	4800	5160	5380	5630	5980	7150	7200	7250	7300	7350	7400	7500	
240	2400	2400	2880	3900	4920	5280	5500	5750	6100	7300	7350	7400	7450	7500	7550	7650	
245	2450	2450	2940	3990	5040	5400	5620	5870	6220	7450	7500	7550	7600	7650	7700	7800	
250	2500	2500	3000	4080	5160	5520	5740	6090	6440	7600	7650	7700	7750	7800	7850	7950	
255	2550	2550	3060	4170	5280	5640	5860	6210	6560	7750	7800	7850	7900	7950	8000	8100	
260	2600	2600	3120	4260	5400	5760	5980	6330	6680	7900	7950	8000	8050	8100	8150	8250	
265	2650	2650	3180	4350	5520	5880	6100	6450	6800	8050	8100	8150	8200	8250	8300	8400	
270	2700	2700	3240	4440	5640	6000	6220	6570	6920	8200	8250	8300	8350	8400	8450	8550	
275	2750	2750	3300	4530	5760	6120	6340	6710	7040	8350	8400	8450	8500	8550	8600	8700	
280	2800	2800	3360	4620	5880	6240	6460	6830	7160	8500	8550	8600	8650	8700	8750	8850	
285	2850	2850	3420	4710	6000	6360	6580	6950	7280	8650	8700	8750	8800	8850	8900	9000	
290	2900	2900	3480	4800	6120	6480	6700	7070	7400	8800	8850	8900	8950	9000	9050	9150	
295	2950	2950	3540	4890	6240	6600	6820	7190	7520	8950	9000	9050	9100	9150	9200	9300	
300	3000	3000	3600	4980	6360	6720	6940	7310	7640	9100	9150	9200	9250	9300	9350	9450	
305	3050	3050	3660	5070	6480	6840	7060	7430	7760	9250	9300	9350	9400	9450	9500	9600	
310	3100	3100	3720	5160	6600	6960	7180	7550	7880	9400	9450	9500	9550	9600	9650	9750	
315	3150	3150	3780	5250	6720	7080	7300	7670	8000	9550	9600	9650	9700	9750	9800	9900	
320	3200	3200	3840	5340	6840	7200	7420	7790	8120	9700	9750	9800	9850	9900	9950	10050	
325	3250	3250	3900	5430	6960	7320	7540	7910	8240	9850	9900	9950	10000	10050	10100	10200	
330	3300	3300	3960	5520	7080	7440	7660	8030	8360	10000	10050	10100	10150	10200	10250	10350	
335	3350	3350	4020	5610	7200	7560	7780	8150	8480	10150	10200	10250	10300	10350	10400	10500	
340	3400	3400	4080	5700	7320	7680	7900	8270	8600	10300	10350	10400	10450	10500	10550	10650	
345	3450	3450	4140	5790	7440	7800	8020	8390	8720	10450	10500	10550	10600	10650	10700	10800	
350	3500	3500	4200	5880	7560	7920	8140	8530	8860	10600	10650	10700	10750	10800	10850	10950	
355	3550	3550	4260	5970	7680	8040	8260	8650	8980	10750	10800	10850	10900	10950	11000	11100	
360	3600	3600	4320	6060	7800	8160	8380	8770	9100	10900	10950	11000	11050	11100	11150	11250	
365	3650	3650	4380	6150	7920	8280	8500	8890	9220	11050	11100	11150	11200	11250	11300	11400	
370	3700	3700	4440	6240	8040	8400	8620	9010	9340	11200	11250	11300					

## Caratteristiche del rivestimento TiN – Features of TiN coating Caractéristiques du revêtement TiN – Características del recubrimiento TiN

Il rivestimento monostrato TiN ha lo scopo di incrementare la resistenza a fenomeni di usura e ossidazione cui gli utensili sono sottoposti durante le lavorazioni di foratura: ha ottime caratteristiche di microdurezza (HV 0,05 2300), un basso coefficiente di attrito (0,4), una temperatura massima di esercizio pari a 500°C. Il rivestimento di pochi µm, depositato per via fisica mediante vapore (Physical Vapour Deposition), consente pertanto di aumentare la vita utile degli utensili da taglio, migliorando anche la finitura superficiale ed il conseguente scorrimento dei trucioli di lavorazione.

TiN monolayer coating can increase both wear and oxidation resistance of every tool. It has high hardness (HV 0.05 2300), low friction coefficient (0.4), maximum working temperature 500°C. The coating thickness is very low (µm) and it's produced by Physical Vapour Deposition. TiN coating increases the life cycle of the tool, also improving the surface finishing and the drilling chips removal.

Le revêtement monocouche TiN sert à augmenter la résistance aux phénomènes d'usure et d'oxydation auxquels les outils sont soumis pendant les travaux de perçage : il possède des caractéristiques optimales de microdureté (HV 0,05 2300), un coefficient de frottement faible (0,4), une température maximale de fonctionnement égale à 500°C. Le revêtement de quelques µm, déposé par un procédé physique par le biais de la vapeur (Physical Vapour Deposition), permet donc d'augmenter la vie utile des outils de coupe, en améliorant aussi la finition de la surface et donc l'évacuation des copeaux d'usinage produits.

El recubrimiento monocapa TiN tiene la finalidad de aumentar la resistencia al desgaste y a la oxidación que sufren los utensilios durante los trabajos de perforado: tiene óptimas características de microdureza (HV 0,05 2300), un bajo coeficiente de fricción (0,4), una temperatura máxima de funcionamiento equivalente a 500°C. El recubrimiento de pocos µm, depositado físicamente con vapor (Physical Vapour Deposition), consiente aumentar la duración de los utensilios de corte, mejorando también el acabado superficial y el consiguiente deslizamiento de las virutas generadas durante la actividad.

## Caratteristiche del rivestimento TiAlN – Features of TiAlN coating Caractéristiques du Revêtement TiAlN – Características del recubrimiento TiAlN

È un esclusivo rivestimento PVD che permette il taglio a secco con elevatissimi parametri di taglio e, quindi, con grandissimi rendimenti. Sopporta, infatti temperature di lavoro elevatissime, sino a 800° C, grazie alle caratteristiche uniche del rivestimento TiAlN: supercompatto e durissimo (3300 HV 0,05), con conducibilità termica molto bassa (0,05), basso coefficiente di attrito (0,3), ottima tenacità. Il forte calore sviluppato nella foratura (> 400° C), genera, in ambiente ossidante, Al<sub>2</sub>O<sub>3</sub>, particolarmente resistente alle elevate sollecitazioni termiche, mentre il substrato di TiAlN garantisce una elevata resistenza meccanica. È pertanto adatto al taglio dei materiali fortemente abrasivi (ghisa, leghe Si-Al) degli acciai duri e pastosi come l'acciaio inossidabile, ma anche degli acciai basso legati purché si incrementino notevolmente i 2 parametri di taglio fondamentali: la velocità e l'avanzamento (sino a 2 volte i valori di un utensile HSS convenzionale non rivestito).

This exclusive PVD coating makes dry cutting possible to the highest cutting standards and performance levels. The drill can withstand extremely high working temperatures of up to 800° C on account of the unique properties of the TiAlN coating, namely, it is ultra-thin and exceptionally hard (3300 HV 0,05) with extremely low thermal conductivity (0,05) low friction coefficient (0,3) and excellent toughness. The phenomenal heat created during drilling (>400°C) generates Al<sub>2</sub>O<sub>3</sub>, in oxidizing environments which is particularly resilient to high temperatures whilst the substrate in TiAlN guarantee high mechanical resistance. It is thus suitable for cutting highly abrasive materials (cast iron, Si-Al alloys) and hard, pasty steel such as stainless steel. Nonetheless, it is equally suitable for low alloy steel providing the most important cutting settings (speed and feed) are increased by up to twice the values used for conventional, uncoated HSS tools.

Il s'agit d'un revêtement exclusif PVD qui permet une coupe à sec avec des paramètres de coupe très pointus et donc des rendements très élevés. Il supporte en effet des températures de travail très élevées, jusqu'à 800°C, grâce aux caractéristiques uniques du revêtement TiAlN : ultracompact et très dur (3300 HV 0,05) avec une conductibilité thermique très basse (0,05), un faible coefficient de frottement (0,3), une excellente ténacité. La forte chaleur se dégageant lors du perçage (>400° C) génère, dans un milieu oxydant, de l'Al<sub>2</sub>O<sub>3</sub> particulièrement résistant aux sollicitations thermiques élevées, tandis que la sous-couche de TiAlN garantit une grande résistance mécanique. Il convient par conséquent à la coupe de matériaux fortement abrasifs (fonte, alliages Si-Al), des acier durs et pâteux comme l'acier inoxydable mais aussi des aciers à faible teneur en alliage à condition d'augmenter sensiblement les 2 paramètres fondamentaux de coupe : la vitesse et l'avance (jusqu'à 2 fois les valeurs d'un outil HSS conventionnel sans revêtement).

Es un exclusivo revestimiento PVD que permite el corte seco con parámetros de corte elevadísimos y, por lo tanto, con rendimientos muy grandes. En efecto, soporta temperaturas de trabajo muy elevadas hasta 800° C, gracias a las características únicas de revestimiento TiAlN : supercompacto y durísimo (3300 HV 0,05), con conductibilidad térmica muy baja (0,05) bajo coeficiente de roce (0,3), óptima tenacidad. El fuerte calor desarrollado durante el taladrado (>400° C) genera, en ambiente oxidante, Al<sub>2</sub>O<sub>3</sub>, particularmente resistente a los elevados esfuerzos térmicos, mientras que el substrato de TiAlN garantiza una elevada resistencia mecánica. Por lo tanto es adecuado para el corte de los materiales fuertemente abrasivos (hierro fundido, aleaciones Si-Al), de los aceros duros y pastosos como el acero inoxidable, pero también de los aceros bajo aleados, con tanto de que se incrementen notablemente los 2 parámetros de corte fundamentales: la velocidad y el avance (hasta 2 veces los valores de una herramienta HSS convencional no revestida).

## Scelta della punta per metallo e dei parametri di taglio da usare in funzione del materiale da lavorare

Chart for metal drills selection and relative cutting speeds in accordance with the materials to work



**Punte in acciaio superrapido**  
Twist drills made of high speed steel

Materiale da lavorare Work-piece material	Qualità punta Drill quality	Velocità periferica Peripheral speed  Mt/min	Diametro punta / Drill size - mm						Refrigerante Coolant
			2	5	8	12	16	25	
			Avanzamento/Feed (mm/giro)						
<b>Acciaio non legato da costruzione</b> Common steel / Acier non alliées / Acero no aliado R<600N/mm <sup>2</sup>	HSS HSS-CO	20÷25 25÷30	0.05	0.12	0.20	0.25	0.30	0.40	
<b>Acciaio da costruzione basso legato</b> Low alloy steel / Acier bas alliées / Acero bajo aliado R<700÷900N/mm <sup>2</sup>	HSS HSS-CO	10÷12 15÷18	0.03	0.07	<b>0.10</b>	0.16	0.20	0.25	
<b>Acciaio legato al Ni Cr</b> Ni Cr Steel / Acier au Ni Cr / Acero Ni Cr R<1100÷1300N/mm <sup>2</sup>	HSS HSS-CO	6÷8 8÷10	0.02	0.05	0.08	0.12	0.14	0.18	
<b>Acciaio Inox martensitico ed austenitico</b> Stainless steel / Acier inox / Acero inoxidable <b>Acciaio refrattario Acciaio resistente alla corrosione</b> Heat resistant steel, corrosion resistant steel / Acier réfractaire, acier résistant à la corrosion / Acero refractario y resistente a la corrosión	HSS-CO 5% HSS-CO 8%	6÷8 8÷10	0.02	0.05	0.08	0.12	0.14	0.18	
<b>Acciaio alto legato con tenore di manganese &gt;10%</b> High manganese content steel / Acier haute percentage de manganese / Acero con elevada percentual de manganese	HSS-CO 8%	3÷5	0.02	0.05	0.08	0.12	0.14	0.18	
<b>Superleghe</b> Nimonic, Hastelloy, Inconel	HSS-CO 5% HSS-CO 8%	3÷8	0.02	0.05	0.08	0.12	0.14	0.18	
<b>Titanio e leghe di titanio</b> Titanium alloys / Titan / Titanio	HSS-CO 5% HSS-CO 8%	3÷6	0.02	0.05	0.08	0.12	0.14	0.18	
<b>Nichel, Monel</b>	HSS-CO	10÷12	0.02	0.05	0.08	0.12	0.14	0.18	
<b>Ghisa Grigia 200 HB</b> Cast Iron / Fonte grise / Fundición	HSS HSS-CO	15÷20 20÷25	0.02	0.12	0.20	0.25	0.30	0.40	
<b>Ghisa Grigia 350 HB</b> Cast Iron / Fonte grise / Fundición	HSS HSS-CO	5÷10 20÷25	0.03	0.07	0.10	0.16	0.20	0.25	
<b>Bronzo dolce</b> Soft bronze / Bronze doux / Bronze douce	HSS HSS-CO	20÷35	0.05	0.08	0.14	0.20	0.25	0.30	
<b>Bronzo duro</b> Tough bronze / Bronze dur / Bronze duro	HSS HSS-CO	15÷30	0.05	0.08	0.14	0.20	0.25	0.30	
<b>Ottone dolce</b> Soft brass / Laiton doux / Oton douce	HSS HSS-CO	60÷80	0.08	0.18	0.25	0.30	0.35	0.40	
<b>Ottone tenace</b> Tough brass / Laiton dur / Oton duro	HSS HSS-CO	30÷50	0.05	0.15	0.20	0.25	0.35	0.40	
<b>Rame puro</b> Copper / Cuivre / Cobre	HSS	30÷60	0.05	0.14	0.18	0.22	0.30	0.40	
<b>Rame elettrolitico</b> Electrolite copper / Cuivre electrolite / Cobre elettrolitico	HSS	20÷35	0.05	0.14	0.18	0.22	0.30	0.40	
<b>Alluminio</b> Aluminium / Aluminium / Aluminio	HSS	40÷80	0.05	0.14	0.18	0.22	0.30	0.40	
<b>Leghe alluminio</b> Aluminium alloys / Alliages de alu / Aleaciones de aluminio	HSS	30÷60	0.05	0.14	0.18	0.22	0.30	0.40	
<b>Silumin - Leghe Al-Si</b> Silumin	HSS	30÷50	0.05	0.08	0.14	0.20	0.25	0.30	
<b>Leghe al manganese</b> Manganese alloys / Alliage de manganese / Aleaciones de manganese	HSS	60÷90	0.08	0.18	0.25	0.30	0.35	0.40	
<b>Zinco e sue leghe</b> Zinc alloys / Alliages de Zingue/ Aleaciones de cinc	HSS	30÷50	0.05	0.14	0.18	0.20	0.25	0.30	
<b>Resine termoplastiche (dolci)</b> Soft plastic / Plastique doux / Plastico douce	HSS	20÷40	0.05	0.08	0.14	0.20	0.25	0.30	
<b>Resine termoindurenti (dure)</b> Hard plastic / Plastique dure / Plastico duro	HSS	10÷20	0.05	0.08	0.14	0.20	0.25	0.30	
<b>Plexiglass</b>	HSS	15÷20	0.05	0.08	0.14	0.20	0.25	0.30	
<b>Gomma dura</b> Hard rubber / Caoutchouc dur / Goma dura	HSS	15÷35	0.08	0.18	0.25	0.30	0.35	0.40	
<b>Grafite</b> Graphite / Graphite / Grafite	HSS	3÷6	a mano / by hand / à main / a mano						

Nota: Le punte elicoidali cilindriche rettificate garantiscono la realizzazione di fori di tolleranza H10÷H12  
Fully ground twist drills made holes with H10÷H12 tolerance

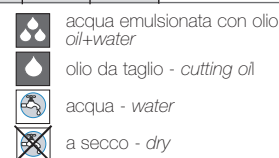

# Conversione della velocità periferica di taglio da m/min in giri/min in funzione del diametro della punta

Cutting speed chart into revolution per minute (RPM), according to the twist drill diameter

2

Diametro punta Drill size $d_1$		Velocità di taglio / Cutting speed $V_t$ (mt/min)													
		3	4	5	6	8	10	12	15	18	20	25	30	35	40
(mm)	pollici (inch)	Velocità di taglio / Cutting speed							n. giri/min (rpm)						
2	5/64	480	640	800	960	1270	1590	1910	2390	2870	3180	3980	4780	5570	6370
3	1/8	320	420	530	640	850	1060	1270	1590	1910	2120	2650	3180	3720	4250
4	5/32	240	320	400	480	640	800	960	1190	1430	1590	1990	2390	2790	3180
5	13/64	190	250	320	380	510	640	760	960	1150	1270	1590	1910	2230	2550
6	15/64	160	210	270	320	420	530	640	800	960	1060	1330	1590	1860	2120
8	5/16	120	160	200	240	320	400	480	600	720	800	1000	1190	1390	1590
10	25/64	95	130	160	190	250	320	380	480	570	640	800	960	1110	1270
12	15/32	80	110	130	160	210	270	320	400	480	530	660	800	930	1060
14	35/64	70	90	110	140	180	230	270	340	410	450	570	680	800	910
16	5/8	60	80	100	120	160	200	240	300	360	400	500	600	700	800
18	23/32	55	70	90	110	140	180	210	270	320	350	440	530	620	710
20	25/32	50	65	80	100	130	160	190	240	290	320	400	480	560	640
22	7/8	45	60	70	85	120	140	170	220	260	290	360	430	510	580
24	15/16	40	55	65	80	110	130	160	200	240	270	330	400	460	530
27	1" 1/16	35	45	60	70	95	120	140	180	210	240	290	350	410	470
30	1" 1/8	30	40	55	65	85	110	130	160	190	210	270	320	370	420
32	1" 1/4	30	40	50	60	80	100	120	150	180	200	250	300	350	400
34	1" 3/8	30	35	45	55	75	95	110	140	170	190	230	280	330	370
36	1" 7/16	25	35	45	55	70	90	110	130	160	180	220	270	310	350
38	1" 1/2	25	35	40	50	65	85	100	130	150	170	210	250	290	340
40	1" 9/16	25	30	40	50	65	80	100	120	140	160	200	240	280	320
42	1" 5/8	25	30	40	45	60	75	90	110	140	150	190	230	270	300
44	1" 3/4	20	30	35	45	60	70	85	110	130	140	180	220	250	290
46	1" 13/16	20	30	35	40	55	70	85	100	120	140	170	210	240	280
48	1" 7/8	20	25	35	40	55	65	80	100	120	130	170	200	230	270
50	2"	20	25	30	40	50	65	75	100	110	130	160	190	220	250

$$n^{\circ} \text{ giri/min (r.p.m.)} = \frac{V_t (\text{Mt/min}) \times 1000}{3,14 \times \varnothing (\text{mm})}$$

Formula di conversione della velocità periferica di taglio da mt/min in n.giri/min in funzione del diametro dell'utensile  
Cutting tip speed conversion formula, from Meter Per Min. to RPM, in accordance with the tool size

### Esempio di utilizzo delle tabelle:

Se si vuole praticare un foro del diametro di 8 mm con una punta HSS, in una lamiera in acciaio comune e si desidera conoscere i parametri di taglio adeguati alla foratura, si dovrà consultare la tabella n. 1 nella quale è indicato che una punta HSS da mm 8 avrà un avanzamento consigliato di 0,1 mm/giro ed una velocità di taglio di 10÷12 mt/min. Per la conversione della velocità da mt/min in giri/min, si consulterà la tabella n.2; incrociando la riga riferita al diametro 8 mm con la colonna che contiene la velocità 12 mt/min si troverà il valore di 480 giri/min. Il foro quindi andrà eseguito con una velocità di 480 giri/min e con un avanzamento di 0,1 mm/giro. Una buona lubrorefrigerazione infine garantirà un ottimo risultato di foratura.

### Charts use example:

If you want to make a hole of 8 mm with an HSS bit into a metal sheet and you wish to know the correct cutting parameters, have a look on the chart n.1 where you can see that an HSS bit has a suggested feed of 0,1 mm/revolution and a cutting speed of 10÷12 mt/minute. For the speed conversion mt/min and rpm, please look at the chart n. 2; crossing the line containing the size 8 mm and the column of speed 10÷12 mt/min, you will find the value of 480 rpm. So that the drill should be made with a speed of 480 rpm with 0,1 mm/revolution feed. An appropriate lubricating finally guarantee the best cutting results.

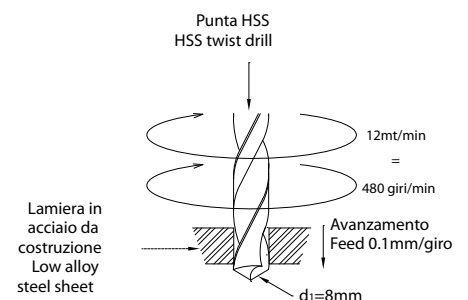

## Parametri di taglio per punte in metallo duro o con placchette in metallo duro per il taglio dei metalli

Recommended cutting parameter chart for tungsten carbide drill bits and carbide tipped twist drills on metals cuttings

3



**Metallo duro**  
**Carbide H.M.**

Materiale da lavorare Work-piece material	Resistenza a trazione/Durezza Tensile strenght/hardness	Velocità di taglio Cutting speed Mt/min	Diametro punta / Drill size - mm						Refrigerante Coolant
			2	2,5	4	5	8	10	
			Avanzamento - Feed - mm/giro						
<b>Acciaio basso legato</b> Low alloy steel	fino / up to 700 N/mm <sup>2</sup>	80-100	0,025	0,0315	0,05	0,05	0,08	0,1	
<b>Acciaio legato e alto legato</b> High alloy steel	fino / up to 900 N/mm <sup>2</sup> oltre / beyond 900 N/mm <sup>2</sup>	70-90 60-70	0,02 0,0125	0,025 0,016	0,04 0,025	0,05 0,025	0,063 0,04	0,08 0,05	
<b>Acciaio per utensili</b> Tool steel	fino / up to 1000 N/mm <sup>2</sup> oltre / beyond 1000 N/mm <sup>2</sup>	50-60 20-40	0,0125 0,01	0,016 0,0125	0,025 0,02	0,025 0,025	0,04 0,0315	0,05 0,04	
<b>Acciaio temprato</b> Tempered steel	fino / up to 60 HRC	10-30	0,0063	0,008	0,0125	0,0125	0,02	0,025	
<b>Acciaio per molle</b> Spring steel		20-50	0,01	0,0125	0,02	0,025	0,0315	0,04	
<b>Acciaio austenitico Cr-Ni, Inox, resistente agli acidi e al calore</b> Austenitic stainless steel, acid resistant steel, heat resistant steel		20-40	0,008	0,01	0,016	0,02	0,025	0,0315	
<b>Acciaio ferritico, inox, resistente al calore</b> Ferritic steel, stainless steel, heat resistant steel		40-60	0,0125	0,016	0,025	0,025	0,04	0,05	
<b>Acciaio duro al Mn</b> Hard Mn steel		20-40	0,0063	0,008	0,0125	0,0125	0,02	0,025	
<b>Acciaio fuso</b> Cast steel	fino / up to 500 N/mm <sup>2</sup> oltre / beyond 500 N/mm <sup>2</sup>	60-80 30-60	0,025 0,016	0,0315 0,02	0,05 0,0315	0,05 0,0315	0,08 0,05	0,1 0,08	
<b>Acciaio fuso legato / Ghisa in conchiglia</b> Alloy cast steel / Chilled iron	fino / up to 350 HB oltre / beyond 350 HB	40-60 20-40	0,0125 0,0063	0,016 0,008	0,025 0,0125	0,025 0,0125	0,04 0,02	0,05 0,025	
<b>Ghisa grigia</b> Grey cast iron	fino / up to GG 40	70-100	0,025	0,0315	0,05	0,05	0,08	0,1	
<b>Ghisa sferoidale / Ghisa malleabile</b> Spheroidal cast iron / Malleable cast iron	fino / up to GGG 60 fino / up to GTW / GTS 55	50-80	0,02	0,025	0,04	0,05	0,063	0,08	
<b>Rame</b> Copper		80-110	0,02	0,025	0,04	0,05	0,063	0,08	
<b>Bronzo</b> Bronze	duro / hard tenero / soft	60-80 100-120	0,016 0,025	0,02 0,0315	0,0315 0,05	0,0315 0,05	0,05 0,08	0,063 0,1	
<b>Leghe di alluminio fino a 11% Si</b> Aluminium alloy up to 11% Si		100-140	0,0135	0,04	0,063	0,063	0,1	0,125	
<b>Leghe di alluminio oltre 11% Si</b> Aluminium alloy beyond 11% Si		60-100	0,02	0,025	0,04	0,05	0,063	0,08	
<b>Ottone, Zn, Bronzo per getti</b> Brass, Zn, Cast bronze		80-110	0,02	0,025	0,04	0,05	0,063	0,08	
<b>Titanio e sue leghe</b> Titanium alloy		20-40	0,01	0,0125	0,02	0,025	0,0315	0,04	
<b>Leghe di magnesio</b> Magnesium alloy		100-150	0,0315	0,04	0,063	0,063	0,1	0,125	
<b>Materie plastiche dure</b> Hard plastics		60-100	0,0315	0,04	0,063	0,063	0,1	0,125	
<b>Materie plastiche tenere, laminati, termoplastici</b> Soft plastics, thermoplastics, laminates		80-150	0,04	0,05	0,08	0,1	0,125	0,16	
<b>Resine epossidiche rinforzate</b> Reinforced epoxy resins		60-100	0,0315	0,04	0,063	0,063	0,1	0,125	

$$n^{\circ} \text{ giri/min (r.p.m.)} = \frac{Vt \text{ (Mt/min)} \times 1000}{3,14 \times \varnothing \text{ (mm)}}$$

Formula di conversione della velocità periferica di taglio da mt/min in n.giri/min in funzione del diametro dell'utensile  
Cutting tip speed conversion formula, from Meter Per Min. to RPM, in accordance with the tool size

## Velocità di taglio per frese a incassare, svasare e sbavare in funzione del materiale da lavorare

Recommended cutting parameter chart for countersinks and deburring tools in accordance with the materials to work

4



**Frese a svasare**  
**Deburring tools**

Materiale da lavorare Work-piece material	Velocità di taglio Cutting speed Mt/min	Refrigerante Coolant
<b>Acciaio non legato</b> Carbon steel	20	
<b>Acciaio legato fino a 700 N/mm<sup>2</sup></b> Alloy steel up to 700 N/mm <sup>2</sup>	15	
<b>Acciaio legato fino a 1000 N/mm<sup>2</sup></b> Alloy steel up to 1000 N/mm <sup>2</sup>	10	
<b>Ghisa fino a 250 N/mm<sup>2</sup></b> Cast iron up to 250 N/mm <sup>2</sup>	10	
<b>Ghisa oltre 250 N/mm<sup>2</sup></b> Cast iron beyond 250 N/mm <sup>2</sup>	8	
<b>Ottone fragile</b> Fragile brass	40	
<b>Ottone plastico</b> Tough brass	20	
<b>Leghe di alluminio fino a 11% Si</b> Aluminium alloys up to 11% Si	20	
<b>Materiale termoplastico</b> Thermoplastics	15	
<b>Materiale termoindurente</b> Thermosetting plastics	10	

## Parametri di taglio per utensili conici in funzione del materiale da lavorare

Recommended cutting parameter chart for conical drill bits in accordance with the materials to work

5



**Utensili conici**  
**Conical drill bits**

Materiale da lavorare Work-piece material	Profondità di foratura Cutting depth mm	Grandezza / Size								Refrigerante Coolant
		1	2	3	4	5	6	7	8	
		3÷14	6÷20	16÷30,5	26÷40	36÷50	40÷61	3÷31	3÷22,5	
Giri/min - rpm										
<b>Acciaio inox e alto legato</b> Stainless steel high alloy steel	1	750	500	280	200	150	130	400	500	
<b>Acciaio basso legato</b> Low alloy steel	2	1100	740	420	300	220	190	580	740	
<b>Ghisa fino a 250 N/mm<sup>2</sup></b> Cast iron up to 250 N/mm <sup>2</sup>	3	560	360	200	150	110	100	300	360	
<b>Ghisa oltre 250 N/mm<sup>2</sup></b> Cast iron beyond 250 N/mm <sup>2</sup>	3	380	240	140	100	80	60	200	240	
<b>Ottone fragile</b> Fragile brass	3	2200	1500	830	600	440	400	1100	1500	
<b>Ottone tenace</b> Tough brass	3	1300	860	480	340	260	220	680	860	
<b>Leghe leggere</b> Light alloys	5	1100	740	420	300	220	190	580	740	
<b>Plastica</b> Plastics	5	1300	860	480	340	260	220	680	860	

## Parametri di taglio per utensili a gradino in funzione del materiale da lavorare

Recommended cutting parameter chart for step drills in accordance with the materials to work

6

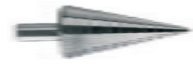

**Utensili a gradino**  
**Step drill bits**

Materiale da lavorare Work-piece material	Profondità di foratura Cutting depth mm	Grandezza / Size																Refrigerante Coolant
		1	2	3	4	5	6	7	8	9	10	11	21	22	23	24		
		4÷12	4÷12	12÷20	4÷20	20÷30	4÷30	30÷40	40÷50	6÷36	6÷58	4÷39	63÷26,75	6÷30,5	6÷37	6÷38		
Giri/min - rpm																		
<b>Acciaio inox e alto legato</b> Stainless steel high alloy steel	3÷4	800	800	400	530	250	380	180	140	300	200	300	400	350	300	300		
<b>Acciaio basso legato</b> Low alloy steel	3÷4	1200	1200	600	800	380	560	280	200	450	300	450	600	530	450	450		
<b>Ghisa fino a 250 N/mm<sup>2</sup></b> Cast iron up to 250 N/mm <sup>2</sup>	3÷4	600	600	300	400	190	280	140	100	230	150	230	300	260	230	230		
<b>Ghisa oltre 250 N/mm<sup>2</sup></b> Cast iron beyond 250 N/mm <sup>2</sup>	3÷4	400	400	200	260	130	190	90	70	150	100	150	200	180	150	150		
<b>Ottone fragile</b> Fragile brass	3÷4	2400	2400	1200	1600	760	1100	550	420	900	600	900	1200	1000	900	900		
<b>Ottone tenace</b> Tough brass	3÷4	1400	1400	700	920	450	650	320	240	530	350	530	700	620	530	530		
<b>Leghe leggere</b> Light alloys	3÷4	1200	1200	600	800	380	560	280	200	450	300	450	600	530	450	450		
<b>Plastica</b> Plastics	3÷4	1400	1400	700	920	450	650	320	240	530	350	530	700	620	530	530		

## Scelta delle velocità di taglio dei maschi a macchina, in funzione del materiale da filettare

Chart for machine taps selection and relative cutting speed in accordance with the materials to work



Maschi a macchina  
Machine taps

Materiale da lavorare Work-piece material	Velocità di taglio Cutting speed (m/min.)	Refrigerante Coolant
<b>Acciaio basso legato</b> Low alloy steel	10÷20	
<b>Acciai refrattari, Acciai per utensili</b> Heat resistant steel, Tool steel	4÷8	
<b>Acciai R&gt;1200 N/mm<sup>2</sup></b> Steel R>1200N/mm <sup>2</sup>	2÷5	
<b>Acciaio inox</b> Stainless steel	5÷10	
<b>Leghe speciali</b> Nimonic, Hastelloy	2÷4	
<b>Ghisa sferoidale</b> Spheroidal cast iron	6÷20	
<b>Ghisa malleabile</b> Malleable cast iron	6÷12	
<b>Ottone truciolo corto</b> Brass short chipping	20÷30	
<b>Ottone truciolo lungo, Leghe di rame, leghe di zinco</b> Brass long chipping, Cu alloy, Zn alloy	10÷15	
<b>Bronzo</b> Bronze	6÷15	
<b>Alluminio truciolo corto</b> Alu Short chipping	15÷30	
<b>Alluminio truciolo lungo, Leghe di magnesio</b> Alu long-chipping, Mg alloy	10÷20	
<b>Titanio</b> Titanium	3÷4	
<b>Plastica e materiali termoplastici</b> Thermoplastics	5÷15	
<b>Materiali termoindurenti</b> Thermosetting materials	5÷10	

**Note / Notes:** Valido per i fori ciechi e passanti / Suited for blind and through holes  
**Consigli / Tips:** Utilizzare per spessori <1,5 Ø dell'utensile  
To be used with thickness < 1,5 Ø of the tool

## Scelta dei maschi a macchina con anelli colorati in funzione del materiale da filettare

Chart for colored rings machine taps selection and relative cutting speed in accordance with the materials to work



Maschi a macchina  
Machine taps

Materiale da lavorare Work-piece material	Velocità di taglio Cutting speed (m/min.)	Refrigerant e Coolant	Art. 10500	Art. 10504	Art. 10508	Art. 10510	Art. 10511	Art. 10513
<b>Acciaio basso legato</b> Low alloy steel	10÷20							
<b>Acciai refrattari, Acciai per utensili</b> Heat resistant steel, Tool steel	4÷8							
<b>Acciai R&gt;1200 N/mm<sup>2</sup></b> Steel R1200>N/mm <sup>2</sup>	2÷5							
<b>Acciaio inox</b> Stainless steel	5÷10							
<b>Leghe speciali</b> Nimonic, Hastelloy	2÷4							
<b>Ghisa sferoidale</b> Spheroidal cast iron	6÷20							
<b>Ghisa malleabile</b> Malleable cast iron	6÷12							
<b>Ottone truciolo corto</b> Brass short chipping	20÷30							
<b>Ottone truciolo lungo Leghe di rame, leghe di zinco</b> Brass long chipping, Cu alloy, Zn alloy	10÷15							
<b>Bronzo</b> Bronze	6÷15							
<b>Alluminio truciolo corto</b> Alu Short chipping	15÷30							
<b>Alluminio truciolo lungo Leghe di magnesio</b> Alu long-chipping, Mg alloy	10÷20							
<b>Titanio</b> Titanium	3÷4							
<b>Plastica e materiali termoplastici</b> Thermoplastics	5÷15							
<b>Materiali termoindurenti</b> Thermosetting materials	5÷10							

**Note / Notes:** Valido per i fori ciechi e passanti / Suited for blind and through holes  
**Consigli / Tips:** Utilizzare per spessori <1,5 Ø dell'utensile  
To be used with thickness < 1,5 Ø of the tool

# Tabella di conversione delle filettature a pollice in misure metriche

Conversion chart from metric to inch threads

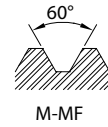

**Metrico-Pollici**  
**Metric-Inches**

9

## BSW

pollici inches	mm	pollici inches	mm	pollici inches	mm	pollici inches	mm
1/16-60	1,59	7/16-14	11,11	1.3/8-6	34,92	3"-3,5	76,20
3/32-48	2,38	1/2-12	12,70	1.1/2-6	38,10	3.1/4-3 1/4	82,55
1/8-40	3,17	9/16-12	14,28	1.5/8-5	41,28	3.1/2-3 1/4	88,90
5/32-32	3,96	5/8-11	15,87	1.3/4-5	44,45	3.3/4-3	95,24
3/16-24	4,76	3/4-10	19,05	1.7/8-4,5	47,63	4"-3	101,60
7/32-24	5,55	7/8-9	22,22	2"-4,5	50,80	4.1/2-2 7/8	114,30
1/4-20	6,35	1"-8	25,40	2.1/4-4	57,15	5"-2 3/4	127,00
5/16-18	7,93	1.1/8-7	28,57	2.1/2-4	63,50	5.1/2-2 5/8	139,70
3/8-16	9,52	1.1/4-7	31,75	2.3/4-3,5	69,85	6" 2,5	152,40

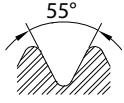

BSP-BSW-BSF

## BSP - BSPT

pollici inches	mm	dist. di misura per BSPT dist. of the measure BSPT	pollici inches	mm	dist. di misura per BSPT dist. of the measure BSPT	pollici inches	mm	dist. di misura per BSPT dist. of the measure BSPT
1/8-28	9,72	10,10	1"-11	33,24	26,00	2.1/4-11	65,71	36,10
1/4-19	13,15	15,00	1.1/8-11	37,89	-	2.1/2-11	75,18	37,10
3/8-19	16,66	15,40	1.1/4-11	41,91	28,30	2.3/4-11	81,53	-
1/2-14	20,95	20,50	1.3/8-11	44,32	-	3"-11	87,88	40,20
5/8-14	22,90	20,10	1.1/2-11	47,80	28,30	4"-11	113,03	-
3/4-14	26,44	21,80	1.3/4-11	53,74	30,30	5"-11	138,43	-
7/8-14	30,20	24,45	2"-11	59,61	32,70			

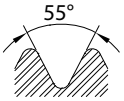

BSPT

1:16

## NPT

pollici inches	mm	dist. di misura dist. of the measure	pollici inches	mm	dist. di misura dist. of the measure	pollici inches	mm	dist. di misura dist. of the measure
1/16-27	7,77	9,85	5/8-14	22,71	20,05	1.3/4-11,5	56,04	27,75
1/8-27	10,12	9,85	3/4-14	26,40	21,35	2"-11,5	59,91	32,15
1/4-18	13,46	14,65	1"-11,5	33,05	25,45	2.1/2-8	72,51	36,30
3/8-18	16,90	15,05	1.1/4-11,5	41,80	27,45	3"-8	88,42	39,40
1/2-14	21,06	20,05	1.1/2-11,5	47,87	27,45			

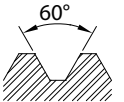

NPT-NPTF

1:16

## UNC-UNF

pollici inches	UNC	UNF	mm	pollici inches	UNC	UNF	mm	pollici inches	UNC	UNF	mm
n.1	64	72	1,85	n.12	24	28	5,48	5/8	11	18	15,87
n.2	56	64	2,18	3/16	24	32	4,76	3/4	10	16	19,05
n.3	48	56	2,51	1/4	20	28	6,35	7/8	9	14	22,22
n.4	40	48	2,84	5/16	18	24	7,93	1"	8	14	25,40
n.5	40	44	3,17	3/8	16	24	9,52	1.1/8	7	12	28,40
n.6	32	40	3,50	7/16	14	20	11,11	1.1/4	7	12	31,75
n.8	32	36	4,16	1/2	13	20	12,70	1.3/8	6	12	34,92
n.10	24	32	4,82	9/16	12	18	14,28	1.1/2	6	12	38,10

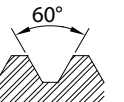

UNC-UNF

## PG

n.	fil. per pollice threads per inch	mm	n.	fil. per pollice threads per inch	mm	n.	fil. per pollice threads per inch	mm
PG 7	20	12,50	PG 16	18	22,50	PG 42	16	54,00
PG 9	18	15,20	PG 21	16	28,30	PG 48	16	59,30
PG 11	18	18,60	PG 29	16	37,00			
PG 13,5	18	20,40	PG 36	16	47,00			

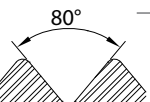

Pg



# Tabella relativa ai prefori di maschiatura

Tapping drill sizes chart

Maschi  
Taps

10

M									
M	Ø mm	M	Ø mm	M	Ø mm	M	Ø mm	M	Ø mm
M 1 x 0,25	0,75	M 2,3 x 0,4	1,9	M 7 x 1	6	M 20 x 2,5	17,5	M 45 x 4,5	40,5
M 1,1 x 0,25	0,85	M 2,5 x 0,45	2,05	M 8 x 1,25	6,8	M 22 x 2,5	19,5	M 48 x 5	43
M 1,2 x 0,25	0,95	M 2,6 x 0,45	2,1	M 9 x 1,25	7,8	M 24 x 3	21	M 52 x 5	47
M 1,4 x 0,3	1,1	M 3 x 0,5	2,5	M 10 x 1,5	8,5	M 27 x 3	24		
M 1,6 x 0,35	1,25	M 3,5 x 0,6	2,9	M 11 x 1,5	9,5	M 30 x 3,5	26,5	M 3 x 0,6	2,4
M 1,7 x 0,35	1,3	M 4 x 0,7	3,3	M 12 x 1,75	10,2	M 33 x 3,5	29,5	M 3,5 x 0,75	2,75
M 1,8 x 0,35	1,45	M 4,5 x 0,75	3,7	M 14 x 2	12	M 36 x 4	32	M 4 x 0,75	3,25
M 2 x 0,4	1,6	M 5 x 0,8	4,2	M 16 x 2	14	M 39 x 4	35	M 5 x 0,9	4,1
M 2,2 x 0,45	1,75	M 6 x 1	5	M 18 x 2,5	15,5	M 42 x 4,5	37,5		

MF									
MF	Ø mm	MF	Ø mm	MF	Ø mm	MF	Ø mm	MF	Ø mm
M 3 x 0,35	2,65	M 12 x 1	11	M 20 x 1,5	18,5	M 30 x 1,5	28,5	M 42 x 2	40
M 3,5 x 0,35	3,15	M 12 x 1,25	10,8	M 20 x 2	18	M 30 x 2	28	M 42 x 3	39
M 4 x 0,35	3,65	M 12 x 1,5	10,5	M 22 x 1	21	M 32 x 1,5	30,5	M 45 x 1,5	43,5
M 4 x 0,5	3,5	M 13 x 1	12	M 22 x 1,5	20,5	M 33 x 1,5	31,5	M 45 x 2	43
M 5 x 0,5	4,5	M 13 x 1,5	11,5	M 22 x 2	20	M 33 x 2	31	M 45 x 3	42
M 6 x 0,5	5,5	M 13 x 1,75	11,2	M 24 x 1	23	M 34 x 1,5	32,5	M 48 x 1,5	46,5
M 6 x 0,75	5,2	M 14 x 1	13	M 24 x 1,5	22,5	M 35 x 1,5	33,5	M 48 x 2	46
M 7 x 0,75	6,2	M 14 x 1,25	12,8	M 24 x 2	22	M 36 x 1,5	34,5	M 48 x 3	45
M 8 x 0,5	7,5	M 14 x 1,5	12,5	M 25 x 1	24	M 36 x 2	34	M 50 x 1,5	48,5
M 8 x 0,75	7,2	M 15 x 1	14	M 25 x 1,5	23,5	M 36 x 3	33	M 50 x 2	48
M 8 x 1	7	M 15 x 1,5	13,5	M 26 x 1	25	M 38 x 1,5	36,5	M 50 x 3	47
M 9 x 1	8	M 15 x 2	13	M 26 x 1,5	24,5	M 39 x 1,5	37,5	M 52 x 1,5	50,5
M 10 x 0,5	9,5	M 16 x 1	15	M 27 x 1	26	M 39 x 2	37	M 52 x 2	50
M 10 x 0,75	9,2	M 16 x 1,5	14,5	M 27 x 1,5	25,5	M 39 x 3	36	M 52 x 3	49
M 10 x 1	9	M 18 x 1	17	M 27 x 2	25	M 40 x 1,5	38,5		
M 10 x 1,25	8,8	M 18 x 1,5	16,5	M 28 x 1,5	26,5	M 40 x 2	38		
M 11 x 1	10	M 18 x 2	16	M 28 x 2	26	M 40 x 3	37		
M 12 x 0,75	10,2	M 20 x 1	19	M 30 x 1	29	M 42 x 1,5	40,5		

BSW									
BSW	Ø mm	BSW	Ø mm	BSW	Ø mm	BSW	Ø mm	BSW	Ø mm
W 3/32	1,8	W 1/4	5,1	W 9/16	12	W 1.1/8	24,75	W 2"	44,5
W 1/8	2,6	W 5/16	6,5	W 5/8	13,5	W 1.1/4	27,75		
W 5/32	3,1	W 3/8	7,9	W 3/4	16,5	W 1.3/8	30,2		
W 3/16	3,6	W 7/16	9,3	W 7/8	19,25	W 1.1/2	33,5		
W 7/32	4,4	W 1/2	10,5	W 1"	22	W 1.3/4	38,5		

BSF									
BSF	Ø mm	BSF	Ø mm	BSF	Ø mm	BSF	Ø mm	BSF	Ø mm
BSF 1/4	5,2	BSF 3/8	8,1	BSF 1/2	11	BSF 3/4	16,5	BSF 1"	22,5
BSF 5/16	6,6	BSF 7/16	9,5	BSF 5/8	14	BSF 7/8	19,5		

UNC

UNC	Ø mm	UNC	Ø mm	UNC	Ø mm	UNC	Ø mm	UNC	Ø mm
No. 1-64	1,5	No. 10-24	3,9	9/16 - 12	12,2	1.3/8 - 6	30,75	3" - 4	70
No. 2-56	1,8	No. 12-24	4,5	5/8 - 11	13,5	1.1/2 - 6	34	3.1/4 - 4	76,2
No. 3-48	2,1	1/4 - 20	5,2	3/4 - 10	16,5	1.3/4 - 5	39,5	3.1/2 - 4	82,6
No. 4-40	2,3	5/16 - 18	6,6	7/8 - 9	19,5	2" - 4,5	51,5		
No. 5-40	2,6	3/8 - 16	8	1" - 8	22,25	2.1/4 - 4,5	51,5		
No. 6-32	2,85	7/16 - 14	9,4	1.1/8 - 7	25	2.1/2 - 4	51,5		
No. 8-32	3,5	1/2 - 13	10,8	1.1/4 - 7	28,25	2.3/4 - 4	63,5		

UNF

UNF	Ø mm	UNF	Ø mm	UNF	Ø mm	UNF	Ø mm	UNF	Ø mm
No. 0-80	1,3	No. 5-44	2,7	1/4-20	5,15	9/16-18	12,9	1.1/8-12	26,5
No. 1-72	1,6	No. 6-40	3	5/16-24	6,9	5/8-18	14,5	1.1/4-12	29,5
No. 2-64	1,9	No. 8-36	3,5	3/8-24	8,5	3/4-16	17,5	1.3/8-12	32,5
No. 3-56	2,1	No. 10-32	4,1	7/16-20	9,9	7/8-14	20,25	1.1/2-12	36
No. 4-48	2,4	No. 12-28	4,7	1/2-20	11,5	1"-12	23,25		

BSP

BSP	Ø mm	BSP	Ø mm	BSP	Ø mm	BSP	Ø mm	BSP	Ø mm
G 1/8	8,8	G 5/8	21	G 1.1/8	35,3	G 1.3/4	51,3	G 2.3/4	78,9
G 1/4	11,8	G 3/4	24,5	G 1.1/4	39,3	G 2"	57	G 3"	85,3
G 3/8	15,25	G 7/8	28,25	G 1.3/8	41,7	G 2.1/4	63,1		
G 1/2	19	G 1"	30,75	G 1.1/2	45,2	G 2.1/2	72,6		

BSPT

BSPT	Ø mm	BSPT	Ø mm	BSPT	Ø mm	BSPT	Ø mm	BSPT	Ø mm
1/8-28	8,20	1/2-14	18,00	7/8-14	27,50	1.1/2-11	44,00	3"-11	84,00
1/4-19	11,00	5/8-14	20,25	1"-11	29,50	2"-11	56,00		
3/8-19	14,50	3/4-14	23,50	1.1/4-11	38,50	2.1/2-11	71,00		

NPT

NPT	Ø mm	NPT	Ø mm	NPT	Ø mm	NPT	Ø mm
1/16-27	6,25	3/8-18	14,5	1"-11,5	29	2"-11,5	56
1/8-27	8,5	1/2-14	18	1.1/4-11,5	38	2.1/2-8	67
1/4-18	11,2	3/4-14	23	1.1/2-11,5	44	3"-8	83

PG

PG	Ø mm	PG	Ø mm	PG	Ø mm	PG	Ø mm	PG	Ø mm
PG 7	11,4	PG 11	17,25	PG 16	21,25	PG 29	35,5	PG 42	52,5
PG 9	14	PG 13,5	19	PG 21	26,9	PG 36	45,5	PG 48	58

Tabella relativa ai preforni di maschiatura per maschi a rullare

Drill size cutting taps chart for forming taps

M

M	Ø mm	M	Ø mm	M	Ø mm	M	Ø mm	M	Ø mm
M 3 x 0,35	2,80	M 5 x 0,5	4,80	M 8 x 1	7,50	M 10 x 1,25	9,40	M 12 x 1,5	11,25
M 4 x 0,5	3,80	M 6 x 0,75	5,60	M 10 x 1	9,50	M 12 x 1,25	11,50	M 14 x 1,5	13,25

# Tabella per filettatura esterna

External thread chart

Filiere  
Dies

12

M									
M	Ø mm	M	Ø mm	M	Ø mm	M	Ø mm	M	Ø mm
M 1 x 0,25	0,97	M 2,3 x 0,4	2,23	M 4,5 x 0,75	4,41	M 12 x 1,75	11,83	M 33 x 3,5	32,73
M 1,1 x 0,25	1,07	M 2,5 x 0,45	2,43	M 5 x 0,8	4,90	M 14 x 2	13,82	M 36 x 4	35,70
M 1,2 x 0,25	1,17	M 2,6 x 0,45	2,53	M 5 x 0,9	4,89	M 16 x 2	15,82	M 39 x 4	38,70
M 1,4 x 0,3	1,36	M 3 x 0,5	2,92	M 6 x 1	5,88	M 18 x 2,5	17,79	M 42 x 4,5	41,69
M 1,6 x 0,35	1,54	M 3 x 0,6	2,91	M 7 x 1	6,88	M 20 x 2,5	19,79	M 45 x 4,5	41,69
M 1,7 x 0,35	1,64	M 3,5 x 0,6	3,41	M 8 x 1,25	7,87	M 22 x 2,5	21,79	M 48 x 5	47,66
M 1,8 x 0,35	1,74	M 3,5 x 0,75	3,41	M 9 x 1,25	8,87	M 24 x 3	23,77	M 52 x 5	51,66
M 2 x 0,4	1,93	M 4 x 0,7	3,91	M 10 x 1,5	9,85	M 27 x 3	26,77		
M 2,2 x 0,45	2,13	M 4 x 0,75	3,91	M 11 x 1,5	10,85	M 30 x 3,5	29,73		

MF									
MF	Ø mm	MF	Ø mm	MF	Ø mm	MF	Ø mm	MF	Ø mm
M 3 x 0,35	2,94	M 12 x 1	11,88	M 20 x 1,5	19,85	M 30 x 1,5	29,85	M 42 x 2	41,82
M 3,5 x 0,35	3,44	M 12 x 1,25	11,86	M 20 x 2	19,82	M 30 x 2	29,82	M 42 x 3	41,76
M 4 x 0,35	3,94	M 12 x 1,5	11,85	M 22 x 1	21,88	M 32 x 1,5	31,85	M 45 x 1,5	44,85
M 4 x 0,5	3,93	M 13 x 1	12,88	M 22 x 1,5	21,85	M 33 x 1,5	32,85	M 45 x 2	44,82
M 5 x 0,5	4,93	M 13 x 1,5	12,85	M 22 x 2	21,82	M 33 x 2	32,82	M 45 x 3	44,76
M 6 x 0,5	5,93	M 13 x 1,75	12,83	M 24 x 1	23,88	M 34 x 1,5	33,85	M 48 x 1,5	47,85
M 6 x 0,75	5,90	M 14 x 1	13,88	M 24 x 1,5	23,85	M 35 x 1,5	34,85	M 48 x 2	47,82
M 7 x 0,75	6,90	M 14 x 1,25	13,86	M 24 x 2	23,82	M 36 x 1,5	35,85	M 48 x 3	47,46
M 8 x 0,5	7,93	M 14 x 1,5	13,85	M 25 x 1	24,88	M 36 x 2	35,82	M 50 x 1,5	49,85
M 8 x 0,75	7,90	M 15 x 1	14,88	M 25 x 1,5	24,85	M 36 x 3	35,76	M 50 x 2	49,82
M 8 x 1	7,83	M 15 x 1,5	14,85	M 26 x 1	25,88	M 38 x 1,5	37,85	M 50 x 3	49,76
M 9 x 1	8,88	M 15 x 2	14,82	M 26 x 1,5	25,85	M 39 x 1,5	38,85	M 52 x 1,5	51,85
M 10 x 0,5	9,93	M 16 x 1	15,88	M 27 x 1	26,88	M 39 x 2	38,82	M 52 x 2	51,82
M 10 x 0,75	9,90	M 16 x 1,5	15,85	M 27 x 1,5	26,85	M 39 x 3	38,76	M 52 x 3	51,76
M 10 x 1	9,88	M 18 x 1	17,88	M 27 x 2	26,82	M 40 x 1,5	39,85		
M 10 x 1,25	9,86	M 18 x 1,5	17,85	M 28 x 1,5	27,85	M 40 x 2	39,82		
M 11 x 1	10,88	M 18 x 2	17,82	M 28 x 2	27,82	M 40 x 3	39,76		
M 12 x 0,75	11,90	M 20 x 1	19,88	M 30 x 1	29,88	M 42 x 1,5	41,85		

BSW							
BSW	Ø mm	BSW	Ø mm	BSW	Ø mm	BSW	Ø mm
W 1.1/4	6,16	W 7/16	10,89	W 5/8	15,62	W 1"	25,08
W 5/16	7,76	W 1/2	12,43	W 3/4	18,76	W 1.1/8	28,21
W 3/8	9,30	W 9/16	13,92	W 7/8	21,89		

BSF							
BSF	Ø mm	BSF	Ø mm	BSF	Ø mm	BSF	Ø mm
BSF 3/16	4,67	BSF 3/8	9,39	BSF 9/16	14,12	BSF 7/8	22,02
BSF 1/4	6,25	BSF 7/16	10,97	BSF 5/8	15,71	BSF 1"	25,17
BSF 5/16	7,82	BSF 1/2	12,54	BSF 3/4	18,85		

UNC									
UNC	Ø mm	UNC	Ø mm	UNC	Ø mm	UNC	Ø mm	UNC	Ø mm
No. 1-64	1,79	No. 8-32	4,07	7/16-14	10,95	1"-8	25,16	2"-4.5	50,45
No. 2-56	2,12	No. 10-24	4,71	1/2-13	12,52	1.1/8-7	28,31	2.1/4-4.5	56,80
No. 3-48	2,44	No. 12-24	5,37	9/16-12	14,10	1.1/4-7	31,49	2.1/2-4	63,10
No. 4-40	2,76	1/4-20	6,22	5/8-11	15,68	1.3/8-6	34,63	2.3/4-4	69,45
No. 5-40	3,09	5/16-18	7,80	3/4-10	18,84	1.1/2-6	37,81	3"-4	75,80
No. 6-32	3,41	3/8-16	9,37	7/8-9	22	1.3/4-5	44,12		

UNF									
UNF	Ø mm	UNF	Ø mm	UNF	Ø mm	UNF	Ø mm	UNF	Ø mm
No. 0-80	1,47	No. 5-44	3,10	1/4-28	6,24	9/16-18	14,14	1.1/8-12	28,38
No. 1-72	1,79	No. 6-40	3,42	5/16-24	7,82	5/8-18	15,73	1.1/4-12	31,56
No. 2-64	2,12	No. 8-36	4,08	3/8-24	9,41	3/4-16	18,89	1.3/8-12	34,73
No. 3-56	2,44	No. 10-32	4,73	7/16-20	10,98	7/8-14	22,05	1.1/2-12	37,91
No. 4-48	2,77	No. 12-28	5,38	1/2-20	12,56	1"-12	25,21		

BSP									
BSP	Ø mm	BSP	Ø mm	BSP	Ø mm	BSP	Ø mm	BSP	Ø mm
G 1/8	9,62	G 1/2	20,81	G 7/8	30,06	G 1.1/4	41,73	G 1.3/4	53,56
G 1/4	13,03	G 5/8	22,77	G 1"	33,07	G 1.3/8	44,14	G 2"	59,43
G 3/8	16,53	G 3/4	26,30	G 1.1/8	37,71	G 1.1/2	47,62		

NPT									
NPT	Ø mm	NPT	Ø mm	NPT	Ø mm	NPT	Ø mm	NPT	Ø mm
1/16	8,17	1/4	14,10	1/2	21,85	1"	34,16	1.1/2	48,87
1/8	10,55	3/8	17,52	3/4	27,16	1.1/4	42,74	2"	60,95

PG									
PG	Ø mm	PG	Ø mm	PG	Ø mm	PG	Ø mm	PG	Ø mm
PG 7	12,4	PG 11	18,5	PG 16	22,4	PG 29	36,85	PG 42	53,85
PG 9	15,1	PG 13,5	20,3	PG 21	28,15	PG 36	46,85	PG 48	59,15

Dimensioni tipiche di codolo e quadro dei maschi, in funzione della norma di produzione  
Dimension of shank and square depending on the applicable standard

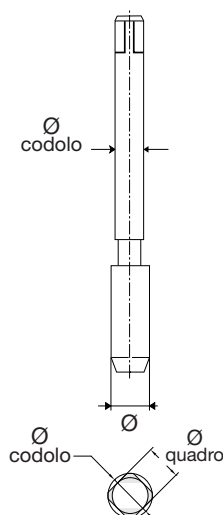

Ø Codolo /Shank	Ø Quadro /Square	DIN 352	DIN 371	DIN 376	DIN 374
2,5	2,1	M1±1,8	M1±1,8	M3,5	M3,5
2,8	2,1	M2±2,5	M2±2,5	M4	M4
3,2	2,4				
3,5	2,7	M3	M3	M5	M5
4	3	M3,5	M3,5		
4,5	3,4	M4	M4	M6	M5,5÷6
6	4,9	M5÷8	M5÷6	M8	M8
7	5,5	M10		M10	M9÷10
8	6,2		M8		
9	7	M12		M12	M12
10	8		M10		
11	9	M14		M14	M14
12	9	M16		M16	M16
14	11	M18		M18	M18
16	12	M20		M20	M20
18	14,5	M22÷24		M22÷24	M22÷24
20	16	M27		M27	M27÷28
22	18	M30		M30	M30
25	20	M33		M33	M33
28	22	M36		M36	M36
32	24	M39÷42		M39÷42	M39÷42
36	29	M45÷48		M45÷48	M45÷48
40	32	M52		M52	

# Diametro della punta in funzione delle dimensioni del filetto da ripristinare

Drill diameter according to thread dimension to be restored

14



## 10606 - M/MF

	Filetto Thread	Ø Drill size mm.	Filetto Thread	Ø Drill size mm.	Filetto Thread	Ø Drill size mm.	Filetto Thread	Ø Drill size mm.
M	2 x 0,4	2,10	10 x 1,25	10,30	18 x 2,5	18,60	27 x 3	27,75
	2,2 x 0,45	2,30	10 x 1	10,30	18 x 2	18,50	27 x 2	27,50
	2,5 x 0,45	2,60	11 x 1,5	11,40	18 x 1,5	18,50	27 x 1,5	27,50
	3 x 0,5	3,20	12 x 1,75	12,40	20 x 2,5	20,60	28 x 1,5	28,50
	3,5 x 0,6	3,70	12 x 1,5	12,40	20 x 2	20,50	30 x 3,5	31,00
	4 x 0,7	4,20	12 x 1,25	12,30	20 x 1,5	20,50	30 x 2	30,50
	5 x 0,8	5,20	12 x 1	12,30	22 x 2,5	22,60	30 x 1,5	30,50
	6 x 1	6,30	14 x 2	14,50	22 x 2	22,50	33 x 3,5	34,00
	7 x 1	7,30	14 x 1,5	14,40	22 x 1,5	22,50	33 x 2	33,50
	8 x 1,25	8,30	14 x 1,25	14,40	24 x 3	24,75	36 x 4	37,00
	8 x 1	8,30	14 x 1	14,30	24 x 2	24,50	36 x 3	37,00
	9 x 1,25	9,30	16 x 2	16,50	24 x 1,5	24,50	36 x 2	36,50
	10 x 1,5	10,40	16 x 1,5	16,40	26 x 1,5	26,50	36 x 1,5	36,50

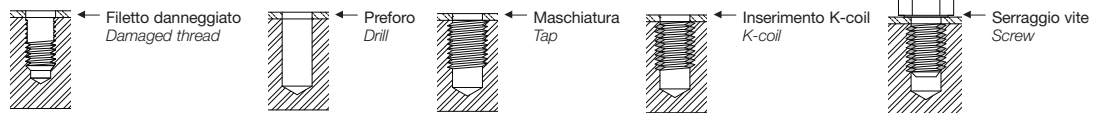

## 10607 - UNC

	Filetto Thread	Ø Drill size mm.	Filetto Thread	Ø Drill size mm.	Filetto Thread	Ø Drill size mm.	Filetto Thread	Ø Drill size mm.
N.	8 x 32	4,40	5/16 x 18	8,30	9/16 x 12	14,80	1" x 8	26,25
	10 x 24	5,10	3/8 x 16	9,90	5/8 x 11	16,50	1.1/8 x 7	29,50
	12 x 24	5,70	7/16 x 14	11,60	3/4 x 10	19,75	1.1/4 x 7	33,00
UNC	1/4 x 20	6,70	1/2 x 13	13,00	7/8 x 9	23,00	1.1/2 x 6	39,50

## 10608 - UNF

	Filetto Thread	Ø Drill size mm.	Filetto Thread	Ø Drill size mm.	Filetto Thread	Ø Drill size mm.	Filetto Thread	Ø Drill size mm.
N.	8 x 36	4,40	3/8 x 24	9,80	5/8 x 18	16,25	1.1/8 x 12	29,00
	10 x 32	5,10	7/16 x 20	11,50	3/4 x 16	19,50	1.1/4 x 12	32,50
	1/4 x 28	6,60	1/2 x 20	13,00	7/8 x 14	22,75	1.1/2 x 12	38,50
UNF	5/16 x 24	8,20	9/16 x 18	14,80	1" x 12	26,00		

## 10609 - BSW

	Filetto Thread	Ø Drill size mm.	Filetto Thread	Ø Drill size mm.	Filetto Thread	Ø Drill size mm.	Filetto Thread	Ø Drill size mm.
	1/8 x 40	3,40	5/16 x 18	8,30	1/2 x 12	13,00	3/4 x 10	20,00
	3/16 x 24	5,10	3/8 x 16	9,90	9/16 x 12	14,80	7/8 x 9	23,00
	1/4 x 20	6,70	7/16 x 14	11,60	5/8 x 11	16,70	1" x 8	26,50

## 10610 - BSF

	Filetto Thread	Ø Drill size mm.	Filetto Thread	Ø Drill size mm.	Filetto Thread	Ø Drill size mm.	Filetto Thread	Ø Drill size mm.
	3/16 x 32	5,00	3/8 x 20	9,90	9/16 x 16	14,80	7/8 x 11	22,70
	1/4 x 26	6,60	7/16 x 18	11,60	5/8 x 14	16,40	1" x 10	26,50
	5/16 x 22	8,30	1/2 x 16	13,00	3/4 x 12	19,50		

## 10604 - BSP

	Filetto Thread	Ø Drill size mm.	Filetto Thread	Ø Drill size mm.	Filetto Thread	Ø Drill size mm.	Filetto Thread	Ø Drill size mm.
G	1/8 x 28	10,00	3/8 x 19	17,10	5/8 x 14	23,40	7/8 x 14	30,60
	1/4 x 19	13,60	1/2 x 14	21,50	3/4 x 14	27,00	1" x 11	33,70

# Dimensioni caratteristiche degli inserti filettati metrici

Metric wire-thread insert dimensions

15



Metric

	Diametro Punta per preforo (mm) <i>Drill size</i>	Diametro Coil non installato min (mm) <i>Ø Coil free min</i>	Diametro Coil non installato max (mm) <i>Ø Coil free max</i>	Profondità di foratura min (mm) <i>Drilling depth</i>	Profondità di filettatura min (mm) <i>Threading depth</i>	Lunghezza nominale Coil installato (mm) <i>Coil lenght inside its site</i>	N. spire del Coil min <i>N coil min</i>	N. spire del Coil max <i>N coil max</i>
2X0,4	2,1	2,49	2,70	4,80	4,40	3,00	5,2	5,7
2,2X0,45	2,3	2,76	3,00	5,33	4,88	3,30	5,0	5,5
2,5X0,45	2,6	3,05	3,70	5,78	5,33	3,75	5,2	6,5
3X0,5	3,2	3,61	4,35	6,75	6,25	4,50	5,8	7,2
3,5X0,6	3,7	4,24	4,95	7,95	7,35	5,25	5,8	7,0
4X0,7	4,2	4,86	5,60	9,15	8,45	6,00	5,7	6,8
5X0,8	5,2	5,98	6,80	11,10	10,30	7,50	6,5	7,6
6X1	6,3	7,23	7,95	13,50	12,50	9,00	6,4	7,2
7X1	7,3	8,22	9,20	15,00	14,00	10,50	7,7	8,7
8X1,25	8,3	9,53	10,35	17,63	16,38	12,00	7,1	7,8
8X1	8,3	9,39	10,25	16,50	15,50	12,00	9,1	10,0
9X1,25	9,4	10,52	11,16	19,13	17,88	13,50	8,4	9,0
10X1,5	10,4	11,83	12,50	21,75	20,25	15,00	7,7	8,2
10X1,25	10,3	11,74	12,65	20,63	19,38	15,00	9,2	10,0
10X1	10,3	11,41	12,50	19,50	18,50	15,00	11,7	12,9
11X1,5	11,4	12,82	13,59	23,25	21,75	16,50	8,6	9,2
12X1,75	12,5	14,13	15,00	25,88	24,13	18,00	7,9	8,5
12X1,5	12,4	14,09	15,20	24,75	23,25	18,00	9,2	10,0
12X1,25	12,3	13,76	15,00	23,63	22,38	18,00	11,2	12,4
12X1	12,3	13,43	14,49	22,50	21,50	18,00	14,7	15,9
14X2	14,5	16,43	17,35	30,00	28,00	21,00	8,2	8,7
14X1,5	14,4	16,11	17,25	27,75	26,25	21,00	11,1	12,0
14X1,25	14,3	15,78	17,03	26,63	25,38	21,00	13,6	14,7
14X1	14,3	15,45	16,68	25,50	24,50	21,00	17,4	18,9
16X2	16,5	18,41	19,60	33,00	31,00	24,00	9,5	10,2
16X1,5	16,5	18,13	19,60	30,75	29,25	24,00	12,8	13,9
18X2,5	18,8	21,04	22,00	38,25	35,75	27,00	8,6	9,0
18X2	18,5	20,80	21,85	36,00	34,00	27,00	10,9	11,5
18X1,5	18,5	20,15	21,75	33,75	32,25	27,00	14,6	15,9
20X2,5	20,8	23,02	24,40	41,25	38,75	30,00	9,6	10,2
20X2	20,5	22,82	24,05	39,00	37,00	30,00	12,2	12,9
20X1,5	20,5	22,17	24,00	36,75	35,25	30,00	16,4	17,9
22X2,5	22,8	25,00	26,90	44,25	41,75	33,00	10,5	11,4
22X2	22,5	24,84	26,50	42,00	40,00	33,00	13,4	14,4
22X1,5	22,5	24,19	26,45	39,75	38,25	33,00	18,1	19,9
24X3	25,0	27,62	29,00	49,50	46,50	36,00	9,7	10,2
24X2	24,5	26,86	29,10	45,00	43,00	36,00	14,6	15,9
24X1,5	24,5	26,21	28,28	42,75	41,25	36,00	20,1	21,8
26X1,5	26,5	28,23	30,46	45,75	44,25	39,00	22,0	23,8
27X3	28,0	30,59	32,40	54,00	51,00	40,50	11,0	11,7
27X2	27,5	29,89	32,30	49,50	47,50	40,50	16,7	18,1
30X3,5	31,0	34,20	35,81	60,75	57,25	45,00	10,5	11,1
30X2	30,5	32,92	35,70	54,00	52,00	45,00	18,7	20,4
33X3,5	34,0	37,17	38,80	65,25	61,75	49,50	11,8	12,4
33X2	33,5	35,95	39,20	58,50	56,50	49,50	20,6	22,6
36X4	37,0	40,78	42,67	72,00	68,00	54,00	11,2	11,7
36X3	37,0	40,30	42,70	67,50	64,50	54,00	14,9	15,9

## Dimensioni caratteristiche degli inserti filettati UNC

UNC wire-thread insert dimensions

16



UNC

	Diametro Punta per preforo (mm) <i>Drill size</i>	Diametro Coil non installato min (mm) <i>Ø Coil free min</i>	Diametro Coil non installato max (mm) <i>Ø Coil free max</i>	Profondità di foratura min (mm) <i>Drilling depth</i>	Profondità di filettatura min (mm) <i>Threading depth</i>	Lunghezza nominale Coil installato (mm) <i>Coil length inside its site</i>	N. spire del Coil min <i>N coil min</i>	N. spire del Coil max <i>N coil max</i>
NO. 8 X32	4,4	5,08	5,59	9,83	9,02	6,25	5,50	6,10
NO.10 X24	5,1	6,10	6,60	11,99	10,92	7,24	4,60	5,00
NO.12 X24	5,7	6,86	7,11	12,98	11,94	8,23	5,60	6,00
1/4 X20	6,7	7,87	8,38	15,24	13,97	9,53	5,30	5,70
5/16 X18	8,3	9,65	10,16	18,24	16,84	11,91	6,30	6,70
3/8 X16	9,9	11,43	11,94	21,44	19,84	14,27	6,80	7,20
7/16 X14	11,6	13,21	13,97	24,82	23,01	16,66	7,00	7,40
1/2 X13	13,0	14,99	15,75	27,84	25,88	19,05	7,50	8,00
9/16 X12	15,0	16,76	17,53	30,96	28,83	21,44	7,90	8,40
5/8 X11	16,5	18,80	19,56	34,21	31,90	23,80	8,10	8,50
3/4 X10	19,8	22,10	23,11	40,01	37,47	28,58	9,00	9,50
7/8 X9	23,0	25,65	26,67	46,02	43,21	33,32	9,60	10,00
1' X8	26,2	29,21	30,48	52,37	49,20	38,10	9,80	10,20
1.1/8 X7	29,5	33,02	34,54	59,18	55,55	42,85	9,60	10,10
1.1/4 X7	32,5	36,07	37,59	63,96	60,33	47,63	10,90	11,40
1.1/2 X6	39,5	43,18	44,96	76,20	71,96	57,15	11,20	11,70

## Dimensioni caratteristiche degli inserti filettati UNF

UNF wire-thread insert dimensions

17



UNF

	Diametro Punta per preforo (mm) <i>Drill size</i>	Diametro Coil non installato min (mm) <i>Ø Coil free min</i>	Diametro Coil non installato max (mm) <i>Ø Coil free max</i>	Profondità di foratura min (mm) <i>Drilling depth</i>	Profondità di filettatura min (mm) <i>Threading depth</i>	Lunghezza nominale Coil installato (mm) <i>Coil length inside its site</i>	N. spire del Coil min <i>N coil min</i>	N. spire del Coil max <i>N coil max</i>
NO. 8X36	4,4	5,08	5,59	9,42	8,71	6,25	6,1	6,9
NO.10X32	5,1	5,84	6,60	10,82	10,01	7,24	6,4	7,2
1/4 X28	6,6	7,62	8,38	13,61	12,70	9,53	7,7	8,5
5/16 X24	8,2	9,40	10,16	16,66	15,60	11,91	8,5	9,2
3/8 X24	9,8	10,92	11,94	19,05	17,98	14,27	10,5	11,4
7/16 X20	11,5	12,95	13,97	22,38	21,11	16,66	10,2	11,1
1/2 X20	13,0	14,48	15,75	24,77	23,50	19,05	11,9	12,9
9/16 X18	14,7	16,26	17,53	27,76	26,37	21,44	12,2	13,3
5/8 X18	16,3	17,78	19,30	30,15	28,75	23,80	13,8	14,9
3/4 X16	19,5	21,34	22,86	35,71	34,14	28,58	14,7	15,9
7/8 X14	22,5	24,89	26,67	41,50	39,67	33,32	15,1	16,3
1' X12	26,0	28,45	30,48	47,63	45,52	38,10	14,8	16
1.1/8X12	29,5	31,75	33,78	52,37	50,27	42,85	16,9	18,2
1.1/4X12	32,5	34,80	37,34	57,15	55,04	47,63	19	20,4
1.1/2X12	38,5	41,15	44,45	66,68	64,57	57,15	23,1	24,9

## Dimensioni caratteristiche degli inserti filettati BSW

BSW wire-thread insert dimensions

18



BSW

	Diametro Punta per preforo (mm) <i>Drill size</i>	Diametro Coil non installato min (mm) <i>Ø Coil free min</i>	Diametro Coil non installato max (mm) <i>Ø Coil free max</i>	Profondità di foratura min (mm) <i>Drilling depth</i>	Profondità di filettatura min (mm) <i>Threading depth</i>	Lunghezza nominale Coil installato (mm) <i>Coil length inside its site</i>	N. spire del Coil min <i>N coil min</i>	N. spire del Coil max <i>N coil max</i>
1/8X40	3,4	3,81	4,32	7,62	6,99	4,75	5,1	5,8
3/16X24	5,0	5,84	6,60	11,91	10,85	7,14	4,6	5,1
1/4 X20	6,7	7,87	8,38	15,24	13,97	9,53	5,4	5,9
5/16 X18	8,3	9,40	10,16	18,24	16,84	11,91	6,4	6,9
3/8 X16	10,0	11,18	11,94	21,44	19,84	14,27	6,9	7,4
7/16 X14	11,6	13,21	13,97	24,82	23,01	16,66	7,1	7,6
1/2 X12	13,0	14,99	16,00	28,58	26,47	19,05	7,0	7,4
9/16X12	14,8	16,51	17,53	30,96	28,83	21,44	8,0	8,6
5/8X11	16,7	18,29	19,56	34,21	31,90	23,80	8,2	8,7
3/4X10	20,0	21,84	22,86	40,01	37,47	28,58	9,2	9,7
7/8X9	23,2	25,15	26,67	46,02	43,21	33,32	9,7	10,2
1"X8	26,5	28,70	30,48	52,37	49,20	38,10	9,9	10,4

## Dimensioni caratteristiche degli inserti filettati BSF

BSF wire-thread insert dimensions

19



BSF

	Diametro Punta per preforo (mm) <i>Drill size</i>	Diametro Coil non installato min (mm) <i>Ø Coil free min</i>	Diametro Coil non installato max (mm) <i>Ø Coil free max</i>	Profondità di foratura min (mm) <i>Drilling depth</i>	Profondità di filettatura min (mm) <i>Threading depth</i>	Lunghezza nominale Coil installato (mm) <i>Coil length inside its site</i>	N. spire del Coil min <i>N coil min</i>	N. spire del Coil max <i>N coil max</i>
3/16X32	5,0	5,84	6,35	10,72	9,91	7,14	6,5	7,2
1/4 X26	6,6	7,62	8,38	13,92	12,95	9,53	7,1	7,9
5/16 X22	8,3	9,40	10,16	17,09	15,95	11,91	7,7	8,5
3/8 X20	9,8	11,18	12,19	19,99	18,72	14,27	8,6	9,4
7/16 X18	11,6	12,95	14,22	23,01	21,62	16,66	9,1	10,0
1/2 X16	13,2	14,73	16,00	26,19	24,61	19,05	9,3	10,2
9/16X16	14,8	16,26	17,78	28,58	26,97	21,44	10,6	11,7
5/8X14	16,3	18,29	19,56	31,98	30,15	23,80	10,4	11,3
3/4X12	19,5	21,84	23,37	38,10	35,99	28,58	10,8	11,7
7/8X11	22,8	25,15	27,18	43,74	41,43	33,32	11,6	12,6
1"X10	26,2	28,70	30,99	49,53	46,99	38,10	12,1	13,2

## Dimensioni caratteristiche degli inserti filettati BSP

BSP wire-thread specific insert dimensions

20



BSP

	Diametro Punta per preforo (mm) <i>Drill size</i>	Diametro Coil non installato min (mm) <i>Ø Coil free min</i>	Diametro Coil non installato max (mm) <i>Ø Coil free max</i>	Profondità di foratura min (mm) <i>Drilling depth</i>	Profondità di filettatura min (mm) <i>Threading depth</i>	Lunghezza nominale Coil installato (mm) <i>Coil length inside its site</i>	N. spire del Coil min <i>N coil min</i>	N. spire del Coil max <i>N coil max</i>
1/8X28	10,0	10,92	11,94	8,84	7,92	4,75	3,2	3,6
1/4X19	13,6	14,99	16,26	15,54	14,20	9,53	5	5,4
3/8X19	17,1	18,54	20,07	20,29	18,97	14,27	8,2	8,9
1/2X14	21,5	23,37	25,15	27,20	25,40	19,05	8,1	8,8
5/8X14	23,4	25,40	27,43	31,95	30,15	23,80	10,4	11,3
3/4X14	27,0	28,96	31,24	36,73	34,93	28,58	12,9	13,9
7/8X14	30,5	32,77	35,31	41,50	39,67	33,32	15,3	16,5
1"X11	33,7	36,32	39,12	48,49	46,18	38,10	13,6	14,7



## Velocità di taglio espresse in m/min per alesatori in funzione del materiale da lavorare

Cutting speed chart in m/min for reamers according to the work-piece material

Alesatori  
Reamers



Materiale da lavorare <i>Work-piece material</i>	Velocità di taglio <i>Cutting speed (m/min)</i>
Acciaio con R<550 MPa <i>Steel with R&lt;550 MPa</i>	10÷15
Acciaio con 550<R<850 MPa <i>Steel with 550&lt;R&lt;850 MPa</i>	12÷15
Acciaio 850<R<1200 MPa <i>Steel with 850&lt;R&lt;1200 MPa</i>	7÷10
Acciaio inox austenitico <i>Austenitic stainless steel</i>	6÷8
Acciaio inox ferritico o martensitico <i>Ferritic and martensitic stainless steel</i>	5÷6
Acciaio inox duplex o alto legato <i>Duplex and high alloy stainless steel</i>	4÷5
Ghisa nodulare <i>Nodular cast iron</i>	9÷11
Ghisa lamellare <i>Lamellar cast iron</i>	13÷15
Rame e sue leghe a truciolo lungo <i>Copper and long chip alloys</i>	16÷20
Rame e sue leghe a truciolo corto <i>Copper and short chip alloys</i>	20÷24
Plastica <i>Plastics</i>	11÷13
Polimeri termoindurenti <i>Thermosetting polymers</i>	7÷10

## Velocità di taglio espresse in m/min per frese frontali in funzione del materiale da lavorare

Cutting speed chart in m/min for end mills according to the work-piece material

Frese frontali  
End mills



Materiale da lavorare <i>Work-piece material</i>	Velocità di taglio <i>Cutting speed (m/min)</i> HSS-CO	Velocità di taglio <i>Cutting speed (m/min)</i> HSS-CO+TiAIN	Velocità di taglio <i>Cutting speed (m/min)</i> HM
Acciaio con R<550 MPa <i>Steel with R&lt;550 MPa</i>	15÷25	25÷40	40÷80
Acciaio con 550<R<850 MPa <i>Steel with 550&lt;R&lt;850 MPa</i>	10÷15	15÷30	30÷45
Acciaio 850<R<1200 MPa <i>Steel with 850&lt;R&lt;1200 MPa</i>	12÷20	20÷25	25÷30
Acciaio inox austenitico <i>Austenitic stainless steel</i>	12÷15	15÷20	20÷25
Acciaio inox ferritico o martensitico <i>Ferritic and martensitic stainless steel</i>	8÷12	12÷20	20÷22
Acciaio inox duplex o alto legato <i>Duplex and high alloy stainless steel</i>	5÷8	8÷10	10÷12
Ghisa nodulare <i>Nodular cast iron</i>	20÷30	30÷40	40÷50
Ghisa lamellare <i>Lamellar cast iron</i>	15÷20	20÷30	30÷60
Rame e sue leghe a truciolo lungo <i>Copper and long chip alloys</i>	50÷100	100÷110	110÷220
Plastica <i>Plastics</i>	50÷100	100÷170	170÷300
Polimeri termoindurenti <i>Thermosetting polymers</i>	20÷30	30÷45	45÷60

$$\text{n}^\circ \text{ giri/min (r.p.m.)} = \frac{V_t (\text{Mt/min}) \times 1000}{3,14 \times \varnothing (\text{mm})}$$

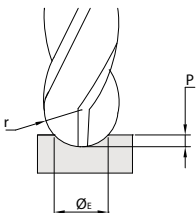

Nel caso di frese frontali raggiate usare  $\varnothing_E$  al posto di  $\varnothing$   
When using ball nose end mills please insert  $\varnothing_E$  instead of  $\varnothing$

$$\varnothing_E = 2\sqrt{P(2r-P)}$$

Tasso di rimozione del materiale T  
Material removing rate T

$$T = \frac{P \times R \times A}{1000} \frac{\text{Cm}^3}{\text{min}}$$

- P Profondità assiale (mm)  
*Axial depth*
- R Profondità radiale (mm)  
*Radial depth*
- A Avanzamento (mm/min)  
*Feed*

# Valori di tolleranza espressi in mm in funzione del diametro dell'utensile

Tolerance values according to the tool diameter

23

Gradi di tolleranza Tolerance grade	Diametro dell'utensile (mm) / Tool diameter (mm)					
	0÷3	3÷6	6÷10	10÷18	18÷30	30÷50
<b>h8</b> (toll. costruttiva delle punte per metallo in acciaio superrapido rettificate) Production tolerance of hss ground twist drills	0 -0,014	0 -0,018	0 -0,022	0 -0,027	0 -0,027	0 -0,039
<b>H10</b> (toll. minima sul foro creato dalle punte per metallo rettificate) Minimum tolerance of the hole made by ground twist drills	+0,040 0	+0,048 0	+0,058 0	+0,070 0	+0,070 0	+0,100 0
<b>H12</b> (toll. massima sul foro creato dalle punte per metallo rettificate) Maximum tolerance of the hole made by ground twist drills	+0,100 0	+0,120 0	+0,150 0	+0,180 0	+0,180 0	+0,250 0
<b>h7</b> (toll. costruttiva delle punte in metallo duro) Production tolerance of carbide twist drills	0 -0,010	0 -0,012	0 -0,015	0 -0,018	0 -0,018	0 -0,025
<b>h10</b> (toll. costruttiva di svasatori e frese frontali in metallo duro) Production tolerance of carbide end mills and deburring tools	0 -0,040	0 -0,048	0 -0,058	0 -0,070	0 -0,070	0 -0,100
<b>G6</b> (toll. sul filetto creato dai maschi sovradimensionati in acciaio superrapido) Production tolerance of the thread made by hss oversized taps	+0,008 +0,002	+0,012 +0,004	+0,014 +0,005	+0,017 +0,006	+0,017 +0,006	+0,025 +0,009
<b>G7</b> (toll. sul filetto creato dai maschi sovradimensionati in acciaio superrapido) Production tolerance of the thread made by hss oversized taps	+0,012 +0,002	+0,016 +0,004	+0,020 +0,005	+0,024 +0,006	+0,024 +0,006	+0,034 +0,009
<b>H7</b> (toll. sul foro creato dagli alesatori) Tolerance of the hole made by the reamers	+0,010 0	+0,012 0	+0,015 0	+0,018 0	+0,018 0	+0,025 0
<b>e8</b> (toll. costruttiva delle frese frontali in acciaio superrapido) Production tolerance of hss end mills	-0,014 -0,028	-0,020 -0,038	-0,025 -0,047	-0,032 -0,059	-0,032 -0,059	-0,050 -0,089
<b>k10</b> (toll. costruttiva delle frese frontali in acciaio superrapido) Production tolerance of hss end mills	+0,040 0	+0,048 0	+0,058 0	+0,070 0	+0,070 0	+0,100 0
<b>k12</b> (toll. costruttiva delle frese frontali in acciaio superrapido) Production tolerance of hss end mills	+0,100 0	+0,120 0	+0,150 0	+0,180 0	+0,180 0	+0,250 0

Nota: I gradi di tolleranza IT5÷IT13 sono idonei agli usuali accoppiamenti meccanici  
IT5÷IT13 tolerance range are suitable for the common mechanical coupling

Cod.	Pag.	Cod.	Pag.	Cod.	Pag.
01022	<a href="#">53</a>	01139	<a href="#">61</a>	01215	<a href="#">139</a>
01028	<a href="#">48</a>	01140	<a href="#">74</a>	01220	<a href="#">60</a>
01034	<a href="#">115</a>	01141	<a href="#">76</a>	01229	<a href="#">60</a>
01050	<a href="#">30</a>	01142	<a href="#">74</a>	01230	<a href="#">148</a>
01051	<a href="#">69</a>	01143	<a href="#">78</a>	01236	<a href="#">149</a>
01057	<a href="#">45</a>	01145	<a href="#">62</a>	01239	<a href="#">147</a>
01058	<a href="#">44</a>	01146	<a href="#">67</a>	01240	<a href="#">142</a>
01059	<a href="#">43</a>	01147	<a href="#">66</a>	01241	<a href="#">143</a>
01060	<a href="#">8</a>	01148	<a href="#">70</a>	01244	<a href="#">144</a>
01062	<a href="#">12</a>	01149	<a href="#">68</a>	01248	<a href="#">145</a>
01063	<a href="#">13</a>	01150	<a href="#">73</a>	01254	<a href="#">150</a>
01066	<a href="#">52</a>	01152	<a href="#">71</a>	01259	<a href="#">142</a>
01067	<a href="#">29</a>	01155	<a href="#">64</a>	01260	<a href="#">121</a>
01068	<a href="#">10</a>	01157	<a href="#">117</a>	01261	<a href="#">122</a>
01069	<a href="#">49</a>	01159	<a href="#">117</a>	01262	<a href="#">123</a>
01079	<a href="#">31</a>	01160	<a href="#">90</a>	01263	<a href="#">124</a>
01088	<a href="#">50</a>	01162	<a href="#">116</a>	01264	<a href="#">125</a>
01089	<a href="#">100</a>	01163	<a href="#">94</a>	01270	<a href="#">120</a>
01090	<a href="#">28</a>	01164	<a href="#">95</a>	01272	<a href="#">136</a>
01091	<a href="#">27</a>	01166	<a href="#">96</a>	01273	<a href="#">134</a>
01092	<a href="#">26</a>	01167	<a href="#">116</a>	01274	<a href="#">135</a>
01093	<a href="#">25</a>	01168	<a href="#">97</a>	01275	<a href="#">134</a>
01094	<a href="#">14</a>	01169	<a href="#">98</a>	01300	<a href="#">72</a>
01095	<a href="#">15</a>	01170	<a href="#">92</a>	01305	<a href="#">75</a>
01096	<a href="#">16</a>	01171	<a href="#">98</a>	01306	<a href="#">77</a>
01097	<a href="#">46</a>	01172	<a href="#">99</a>	01307	<a href="#">79</a>
01098	<a href="#">17</a>	01173	<a href="#">99</a>	01310	<a href="#">72</a>
01099	<a href="#">18</a>	01179	<a href="#">99</a>	01320	<a href="#">88</a>
01100	<a href="#">19</a>	01180	<a href="#">139</a>	01361	<a href="#">104</a>
01101	<a href="#">40</a>	01182	<a href="#">138</a>	01363	<a href="#">105</a>
01102	<a href="#">41</a>	01183	<a href="#">146</a>	01364	<a href="#">36</a>
01103	<a href="#">38</a>	01185	<a href="#">120</a>	01365	<a href="#">37</a>
01104	<a href="#">39</a>	01186	<a href="#">131</a>	01366	<a href="#">108</a>
01105	<a href="#">23</a>	01188	<a href="#">133</a>	01367	<a href="#">112</a>
01110	<a href="#">32</a>	01192	<a href="#">130</a>	01368	<a href="#">106</a>
01111	<a href="#">35</a>	01193	<a href="#">128</a>	01369	<a href="#">110</a>
01112	<a href="#">34</a>	01195	<a href="#">139</a>	01370	<a href="#">20</a>
01114	<a href="#">24</a>	01196	<a href="#">129</a>	01371	<a href="#">21</a>
01115	<a href="#">114</a>	01197	<a href="#">132</a>	01372	<a href="#">22</a>
01117	<a href="#">42</a>	01200	<a href="#">140</a>	01374	<a href="#">32</a>
01118	<a href="#">114</a>	01201	<a href="#">54</a>	01375	<a href="#">33</a>
01119	<a href="#">102</a>	01203	<a href="#">56</a>	10100	<a href="#">320</a>
01120	<a href="#">80</a>	01205	<a href="#">54</a>	10102	<a href="#">325</a>
01122	<a href="#">84</a>	01206	<a href="#">141</a>	10105	<a href="#">326</a>
01123	<a href="#">85</a>	01207	<a href="#">58</a>	10107	<a href="#">331</a>
01126	<a href="#">86</a>	01208	<a href="#">59</a>	10110	<a href="#">335</a>
01128	<a href="#">87</a>	01209	<a href="#">57</a>	10111	<a href="#">336</a>
01135	<a href="#">82</a>	01213	<a href="#">51</a>	10112	<a href="#">337</a>

Cod.	Pag.	Cod.	Pag.	Cod.	Pag.
10115	<a href="#">332</a>	10270	<a href="#">294</a>	10351	<a href="#">276</a>
10117	<a href="#">334</a>	10271	<a href="#">295</a>	10354	<a href="#">277</a>
10120	<a href="#">338</a>	10272	<a href="#">295</a>	10355	<a href="#">277</a>
10122	<a href="#">339</a>	10273	<a href="#">256</a>	10360	<a href="#">287</a>
10125	<a href="#">340</a>	10274	<a href="#">293</a>	10361	<a href="#">289</a>
10127	<a href="#">341</a>	10275	<a href="#">293</a>	10362	<a href="#">310</a>
10134	<a href="#">342</a>	10276	<a href="#">290</a>	10363	<a href="#">311</a>
10136	<a href="#">327</a>	10277	<a href="#">301</a>	10390	<a href="#">276</a>
10139	<a href="#">342</a>	10278	<a href="#">301</a>	10400	<a href="#">278</a>
10144	<a href="#">322</a>	10279	<a href="#">303</a>	10401	<a href="#">278</a>
10146	<a href="#">330</a>	10280	<a href="#">286</a>	10404	<a href="#">279</a>
10147	<a href="#">323</a>	10281	<a href="#">288</a>	10405	<a href="#">279</a>
10148	<a href="#">333</a>	10282	<a href="#">296</a>	10450	<a href="#">278</a>
10155	<a href="#">324</a>	10283	<a href="#">296</a>	10500	<a href="#">314</a>
10162	<a href="#">240</a>	10284	<a href="#">297</a>	10501	<a href="#">314</a>
10165	<a href="#">242</a>	10285	<a href="#">297</a>	10502	<a href="#">315</a>
10168	<a href="#">244</a>	10286	<a href="#">304</a>	10503	<a href="#">315</a>
10171	<a href="#">246</a>	10287	<a href="#">305</a>	10504	<a href="#">312</a>
10172	<a href="#">262</a>	10288	<a href="#">303</a>	10505	<a href="#">312</a>
10173	<a href="#">263</a>	10289	<a href="#">306</a>	10506	<a href="#">313</a>
10174	<a href="#">248</a>	10290	<a href="#">257</a>	10507	<a href="#">313</a>
10177	<a href="#">250</a>	10291	<a href="#">270</a>	10508	<a href="#">316</a>
10180	<a href="#">254</a>	10292	<a href="#">271</a>	10509	<a href="#">316</a>
10183	<a href="#">252</a>	10293	<a href="#">343</a>	10510	<a href="#">319</a>
10210	<a href="#">259</a>	10294	<a href="#">343</a>	10511	<a href="#">317</a>
10212	<a href="#">258</a>	10297	<a href="#">274</a>	10512	<a href="#">317</a>
10230	<a href="#">258</a>	10298	<a href="#">274</a>	10513	<a href="#">318</a>
10240	<a href="#">240</a>	10299	<a href="#">275</a>	10514	<a href="#">318</a>
10250	<a href="#">241</a>	10300	<a href="#">275</a>	10515	<a href="#">308</a>
10251	<a href="#">245</a>	10301	<a href="#">298</a>	10516	<a href="#">309</a>
10252	<a href="#">284</a>	10302	<a href="#">298</a>	10520	<a href="#">312</a>
10253	<a href="#">243</a>	10303	<a href="#">299</a>	10600	<a href="#">374</a>
10254	<a href="#">247</a>	10304	<a href="#">299</a>	10604	<a href="#">385</a>
10255	<a href="#">253</a>	10305	<a href="#">300</a>	10605	<a href="#">375</a>
10256	<a href="#">249</a>	10306	<a href="#">344</a>	10606	<a href="#">382</a>
10257	<a href="#">255</a>	10307	<a href="#">344</a>	10607	<a href="#">384</a>
10258	<a href="#">251</a>	10308	<a href="#">345</a>	10608	<a href="#">384</a>
10259	<a href="#">280</a>	10309	<a href="#">345</a>	10609	<a href="#">385</a>
10260	<a href="#">282</a>	10310	<a href="#">264</a>	10610	<a href="#">385</a>
10261	<a href="#">260</a>	10311	<a href="#">265</a>	10611	<a href="#">390</a>
10262	<a href="#">261</a>	10312	<a href="#">266</a>	10612	<a href="#">386</a>
10263	<a href="#">302</a>	10313	<a href="#">267</a>	10613	<a href="#">388</a>
10264	<a href="#">302</a>	10314	<a href="#">268</a>	10614	<a href="#">388</a>
10265	<a href="#">292</a>	10315	<a href="#">269</a>	10615	<a href="#">389</a>
10266	<a href="#">292</a>	10330	<a href="#">272</a>	10616	<a href="#">389</a>
10267	<a href="#">291</a>	10340	<a href="#">273</a>	10617	<a href="#">389</a>
10268	<a href="#">290</a>	10345	<a href="#">241</a>	10620	<a href="#">387</a>
10269	<a href="#">294</a>	10350	<a href="#">276</a>	10621	<a href="#">391</a>

Cod.	Pag.	Cod.	Pag.	Cod.	Pag.
10622	<a href="#">390</a>	21211	<a href="#">162</a>	24167	<a href="#">205</a>
10623	<a href="#">391</a>	21212	<a href="#">163</a>	24168	<a href="#">207</a>
10625	<a href="#">383</a>	21216	<a href="#">160</a>	24169	<a href="#">208</a>
10628	<a href="#">391</a>	24001	<a href="#">192</a>	24170	<a href="#">210</a>
10631	<a href="#">380</a>	24002	<a href="#">194</a>	24171	<a href="#">209</a>
12060	<a href="#">346</a>	24003	<a href="#">193</a>	24172	<a href="#">211</a>
12062	<a href="#">349</a>	24004	<a href="#">195</a>	24174	<a href="#">212</a>
12065	<a href="#">352</a>	24005	<a href="#">196</a>	24175	<a href="#">213</a>
12066	<a href="#">347</a>	24006	<a href="#">198</a>	24176	<a href="#">238</a>
12069	<a href="#">351</a>	24007	<a href="#">197</a>	24177	<a href="#">234</a>
12070	<a href="#">358</a>	24008	<a href="#">199</a>	24178	<a href="#">236</a>
12072	<a href="#">355</a>	24009	<a href="#">188</a>	24179	<a href="#">231</a>
12075	<a href="#">356</a>	24010	<a href="#">190</a>	24180	<a href="#">223</a>
12077	<a href="#">357</a>	24011	<a href="#">189</a>	24181	<a href="#">216</a>
12079	<a href="#">363</a>	24012	<a href="#">191</a>	24182	<a href="#">215</a>
12080	<a href="#">360</a>	24013	<a href="#">176</a>	24183	<a href="#">214</a>
12082	<a href="#">361</a>	24014	<a href="#">178</a>	24184	<a href="#">217</a>
12085	<a href="#">362</a>	24015	<a href="#">177</a>	24185	<a href="#">235</a>
12086	<a href="#">363</a>	24016	<a href="#">179</a>	24186	<a href="#">237</a>
12087	<a href="#">359</a>	24017	<a href="#">180</a>	26100	<a href="#">224</a>
12088	<a href="#">359</a>	24018	<a href="#">182</a>	28012	<a href="#">161</a>
12089	<a href="#">365</a>	24019	<a href="#">181</a>	28013	<a href="#">161</a>
12091	<a href="#">364</a>	24020	<a href="#">183</a>	28014	<a href="#">161</a>
12093	<a href="#">351</a>	24021	<a href="#">184</a>	28015	<a href="#">161</a>
12144	<a href="#">348</a>	24022	<a href="#">186</a>	28016	<a href="#">154</a>
12146	<a href="#">354</a>	24023	<a href="#">185</a>	29001	<a href="#">170</a>
12148	<a href="#">357</a>	24024	<a href="#">187</a>	29005	<a href="#">173</a>
12165	<a href="#">350</a>	24025	<a href="#">200</a>	29006	<a href="#">172</a>
15001	<a href="#">366</a>	24026	<a href="#">201</a>	29010	<a href="#">171</a>
15003	<a href="#">366</a>	24029	<a href="#">202</a>	29020	<a href="#">166</a>
15010	<a href="#">367</a>	24030	<a href="#">203</a>	29021	<a href="#">167</a>
15011	<a href="#">367</a>	24150	<a href="#">226</a>	29026	<a href="#">168</a>
15030	<a href="#">368</a>	24151	<a href="#">228</a>	29040	<a href="#">169</a>
15032	<a href="#">370</a>	24152	<a href="#">227</a>	29041	<a href="#">169</a>
15035	<a href="#">369</a>	24153	<a href="#">229</a>		
15037	<a href="#">371</a>	24154	<a href="#">224</a>		
17020	<a href="#">320</a>	24155	<a href="#">225</a>		
17020	<a href="#">372</a>	24156	<a href="#">222</a>		
19001	<a href="#">126</a>	24157	<a href="#">230</a>		
19003	<a href="#">127</a>	24158	<a href="#">232</a>		
19020	<a href="#">126</a>	24159	<a href="#">231</a>		
21200	<a href="#">154</a>	24160	<a href="#">233</a>		
21202	<a href="#">155</a>	24161	<a href="#">218</a>		
21204	<a href="#">156</a>	24162	<a href="#">220</a>		
21205	<a href="#">157</a>	24163	<a href="#">219</a>		
21206	<a href="#">158</a>	24164	<a href="#">221</a>		
21207	<a href="#">159</a>	24165	<a href="#">204</a>		
21210	<a href="#">154</a>	24166	<a href="#">206</a>		



## CONDIZIONI GENERALI DI VENDITA

Le condizioni di seguito riportate si intendono accettate dal committente in fase di ordinazione.

1. **ORDINI:** con il conferimento dell'ordine si intendono approvate dal committente tutte le condizioni di vendita in vigore, salvo accordi particolari accettati dai contraenti. Tutti gli ordini sono irrevocabili da parte del committente ma potranno non essere da noi evasi a nostro insindacabile giudizio e senza obbligo di comunicazione o giustificazione. Nell'ordine è necessario specificare il codice dell'articolo.
2. **PREZZI:** i prezzi si intendono per merce franco nostro magazzino (imballo, iva, trasporto esclusi) e non sono impegnativi. I prezzi che avranno valore saranno quelli in vigore al momento della spedizione.
3. **IMBALLO:** gratuito, salvo specifiche richieste del committente, che verranno fatturate al costo.
4. **SPEDIZIONE:** verrà effettuata come segue:
  - a) a mezzo nostro corriere di fiducia, in porto franco con addebito in fattura, in tal caso la merce sarà parzialmente assicurata.
  - b) a mezzo pacco postale o a mezzo corriere di fiducia del committente: la resa sarà franco ns stabilimento di Monticello e la merce viaggia a totale rischio e pericolo del committente. Pertanto in caso di ritardi, ammanchi, avaria, furti, etc. i reclami devono essere indirizzati al Vettore, solo ed unico responsabile.
5. **CONSEGNE:** il termine di consegna, qualora venisse indicato, è puramente indicativo e pertanto solleva la nostra società da ogni qualsivoglia rivalsa.
6. **RECLAMI:** debbono pervenire per iscritto entro 8 giorni dalla data di ricevimento merce. Trascorso tale termine, i reclami non verranno accettati. I reclami di qualsiasi natura non sospendono l'obbligo di effettuare i pagamenti nella forma convenuta. L'acquirente, nel caso che la merce sia da noi ritenuta non idonea, ha diritto esclusivamente alla sostituzione della stessa o all'accredito dell'importo. Ogni altro tipo di indennizzo si intende privo di valore. Per qualsiasi contestazione si elegge unico foro competente quello del Tribunale di Lecco.
7. **RESI:** ogni reso o sostituzione dovrà essere preventivamente autorizzato da KRINO SPA. La merce sarà accettata di ritorno, salvo verifica all'arrivo in magazzino. Questa dovrà essere inviata in porto franco e accompagnata dalla bolla di consegna, con indicati gli estremi della fattura con la quale è stata precedentemente fornita.
8. **PAGAMENTI:** debbono essere effettuati esclusivamente alla nostra sede, secondo le forme concordate. Nel caso di ritardato pagamento, verranno addebitati gli interessi bancari dalla data di scadenza concordata sino all'avvenuto pagamento, maggiorati delle eventuali spese accessorie.
9. **CARATTERISTICHE DEI PRODOTTI:** Le immagini contenute nel presente catalogo sono puramente indicative, pertanto la nostra azienda si riserva il diritto di apportare modifiche migliorative dei prodotti senza nessun obbligo di preavviso.  
**LA RIPRODUZIONE ANCHE PARZIALE DEL PRESENTE CATALOGO E' VIETATA**
10. **VALORE DELL'ORDINE:** Non si assumono ordini di valore inferiore a EURO 250

Ogni qualsivoglia clausola contenuta nel Vs foglio di ordinazione, in contrasto con quanto sopra, si intende priva di valore.

## GENERAL SALES CONDITIONS

1. **ORDERS:** when an order is placed, all conditions are automatically accepted by the client. The order is irrevocable but we reserve the right to accept it. All orders should specify the items numbers.
2. **PRICES:** all prices are ex works (packing, VAT and freight excluded).
3. **PACKAGING:** is free, a part of special requirements extra charged.
4. **SHIPMENT:** It can be CIF with invoice charge, by parcel post or with a forwarding agent suggested by the customer.
5. **DELIVERY TIME:** is purely indicative.
6. **CLAIMS:** They should be notified within 8 days from the date of goods receipt. We shall only arrange free replacement of the tools acknowledged as defective ones by us. In case of dispute, the Civil Court of LECCO will be competent.
7. **GOODS RETURNED:** Any goods return should be authorized by us.
8. **PAYMENTS:** to be made directly to our head office. In case of late payment, we charge the bank interest rate, including additional expenses.
9. **PRODUCTS CHARACTERISTICS:** The images of this catalogue are purely indicatives, we reserve the right to make modifications without any notice. **THE REPRODUCTION OF THIS CATALOGUE IS PROHIBITED.**

Any clause contained into your order sheets which is in contrast with the above mentioned conditions it is not valid.

## CONDITIONS GENERAL DE VENTE

- 1. COMMANDES:** Chaque commande envoyée accepte automatiquement nos conditions de vente. Les commandes sont irrévocables mais nous nous réservons le droit de les accepter. Dans les commandes signalez les codes des références.
- 2. PRIX:** Les prix sont pour marchandise franco départ (emballage, VAT et transport exclus).
- 3. EMBALLAGE:** gratuit, sauf spécifique demande du client et qui sera chargée sur la facture.
- 4. EXPEDITION:** CIF avec charge sur facture, par plis postal ou par le transporteur du client.
- 5. DELAI DE LIVRAISON:** Le délai est seulement indicatif.
- 6. RECLAMATIONS:** Ils doivent être notifiés par écrit dans 8 jours de la date de réception de la marchandise. Ils seront pris en considération si les outils seront reconnus pour nous défectueux. Le Tribunal de LECCO sera compétent en cas de n'importe quelle contestation.
- 7. MERCHANDISE RENDUE:** Chaque envoi doit être autorisé par nous.
- 8. PAIEMENTS:** devront parvenir exclusivement à notre siège en respect des accords pris. En cas de retards nous débiteurons les intérêts de banque et tous les frais accessoires.
- 9. CARACTERISTIQUES DES PRODUITS:** Les images contenues dans ce catalogue là sont indicatives. Notre société se réserve le droit d'apporter des modifications aux produits sans aucune notification. LA REPRODUCTION DE CE CATALOGUE C'EST INTERDIT.

N'importe quelle clause contenue dans Vos commandes et en contradictions avec les conditions ci-dessus n'est pas valable.

## CONDICIONES GENERALES DE VENTA

- 1. PEDIDOS:** con el envío del pedido el cliente acepta automáticamente todas las condiciones de venta.
- 2. PRECIOS:** Los precios son porte debidos (embalajes, IVA y transporte excluidos)
- 3. EMBALAJE:** gratuito. salvo embalaje especial cargado en factura.
- 4. PORTES:** Pagado con cargo en factura, paquete postal, con trasportista del cliente.
- 5. PLAZO DE ENTREGA:** aproximado
- 6. RECLAMACIONES:** Se atenderán todas aquellas reclamaciones que se planten dentro del plazo de los 8 días siguientes a la recepción del material y comunicados sus discrepancias. En caso de litigio el fuero competente es el Tribunal de Lecco.
- 7. DEVOLUCIONES DE MATERIAL:** Es obligatoria autorización de la Empresa para devolución del material.
- 8. PAGO:** El pago debe ser enviado directamente a nuestra casa central.
- 9. CARACTERISTICAS DE LOS PRODUCTOS:** Las imagines de este catalogo son indicativas. Nos reservamos el derecho de modificar cualquier articulo sin previo aviso. LA REPRODUCCION DE ESTE CATALOGO ES PROHIBIDA.

Las clausolas contenidas en sus pedidos y en contra de nuestras condiciones no seran aceptadas.

## ALLGEMEINE VERKAUFSBEDINGUNGEN

- 1. BESTELLUNGEN:** Wenn Sie eine Bestellung unterbreiten, nehmen Sie alle Bedingungen an. Die Bestellung ist unwiderruflich aber wir sind berechtigt sie anzunehmen. Alle Aufträge müssen die Codes des Artikels zeigen.
- 2. PREISE:** Alle Preise sind ab Lager (Verpackung, Vat und Transport ausschluss).
- 3. VERPACKUNG:** kostenlos, Sonder-Verpackung ausschluss (gegen Bezahlung).
- 4. LIEFERUNG:** Die kann „Versicherung und Fracht Kosten“ mit Stellung in Rechnung sein, bei Post oder bei eine Vertrauens-Spediteur der Kunde.
- 5. LIEFERUNGSZEIT:** die Datum ist nur ein Zeigen.
- 6. BESCHWERDE:** Die Kunden müssen in 8 Tagen , nach dem Empfang der Waren, solche Beschwerde anzeigen. Wir können die defekten Werkzeuge kostenlos ersetzen, aber nur wenn die bei uns zurückkommen. Erfüllungsort für sämtliche Verbindlichkeiten ist das Lecco Gericht.
- 7. WARENRÜCKGABEN:** Alle Warenrückgaben müssen bei uns autorisiert sein.
- 8. ZAHLUNGEN:** Die Zahlungen müssen direkt an die Firma vornehmen. Wenn es ein Zahlungsverzug gibt, belasten die Firma Sie die Bankzins, inklusive Zusatz-Kosten.
- 9. KENNZEICHEN DER ARTIKEL:** Die Bilde des Katalogs sind nur Kennzahl. Wir sind berechtigt Abänderung ohne Angabe zu machen. DIE REPRODUKTION DIESES KATALOGS IST VERBOTEN.

Jede Klausel enthält in Ihrer Bestellungen, die in Kontrast mit die überzeichnen Bedingungen ist, wird ungültig.



A.D./ PromarkComunicazione -MB-

PHOTO/ Stefano Tonicello

STAMPA/ Bellavite -MB-

**KRINO S.p.A.**

Via Italia Unita, 21

23876 Monticello Brianza (LC) - Italy

Tel. 039 9230611 (Centralino)

Tel. 039 9230605 (Vendite Italia)

Fax 039 9208709 (Vendite Italia)

Tel. +39 039 9230611 (Switch Board)

Tel. +39 039 9230604 (Export Department)

Fax +39 039 9208712 (Export Department)

[www.krino.it](http://www.krino.it) - [info@krino.it](mailto:info@krino.it)